

FITTER

NSQF LEVEL - 5

2nd Semester

TRADE THEORY

SECTOR: Production & Manufacturing



Directorate General of Training

**DIRECTORATE GENERAL OF TRAINING
MINISTRY OF SKILL DEVELOPMENT & ENTREPRENEURSHIP
GOVERNMENT OF INDIA**



**NATIONAL INSTRUCTIONAL
MEDIA INSTITUTE, CHENNAI**

Post Box No. 3142, CTI Campus, Guindy, Chennai - 600 032

Sector : Production & Manufacturing

Duration : 2 - Years

Trade : Fitter 2nd Semester - Trade Theory - NSQF level 5

Copyright@2018 National Instructional Media Institute, Chennai

First Edition : December 2018

Copies : 10,000

Rs.215/-

All rights reserved.

No part of this publication can be reproduced or transmitted in any form or by any means, electronic or mechanical, including photocopy, recording or any information storage and retrieval system, without permission in writing from the National Instructional Media Institute, Chennai.

Published by:

NATIONAL INSTRUCTIONAL MEDIA INSTITUTE
P. B. No.3142, CTI Campus, Guindy Industrial Estate,
Guindy, Chennai - 600 032.
Phone : 044 - 2250 0248, 2250 0657, 2250 2421
Fax : 91 - 44 - 2250 0791
email : chennai-nimi@nic.in, nimi_bsnl@dataone.in
Website: www.nimi.gov.in

FOREWORD

The Government of India has set an ambitious target of imparting skills to 30 crores people, one out of every four Indians, by 2020 to help them secure jobs as part of the National Skills Development Policy. Industrial Training Institutes (ITIs) play a vital role in this process especially in terms of providing skilled manpower. Keeping this in mind, and for providing the current industry relevant skill training to Trainees, ITI syllabus has been recently updated with the help of Mentor Councils comprising various stakeholder's viz. Industries, Entrepreneurs, Academicians and representatives from ITIs.

The National Instructional Media Institute (NIMI), Chennai has now come up with instructional material to suit the revised curriculum for **Fitter 2nd Semester Trade Theory NSQF Level - 5 in Production & Manufacturing Sector under Semester Pattern**. The NSQF Level - 5 Trade Theory will help the trainees to get an international equivalency standard where their skill proficiency and competency will be duly recognized across the globe and this will also increase the scope of recognition of prior learning. NSQF Level - 5 trainees will also get the opportunities to promote life long learning and skill development. I have no doubt that with NSQF Level - 5 the trainers and trainees of ITIs, and all stakeholders will derive maximum benefits from these IMPs and that NIMI's effort will go a long way in improving the quality of Vocational training in the country.

The Executive Director & Staff of NIMI and members of Media Development Committee deserve appreciation for their contribution in bringing out this publication.

Jai Hind

RAJESH AGGARWAL
Director General/ Addl. Secretary
Ministry of Skill Development & Entrepreneurship,
Government of India.

New Delhi - 110 001

PREFACE

The National Instructional Media Institute (NIMI) was established in 1986 at Chennai by then Directorate General of Employment and Training (D.G.E & T), Ministry of Labour and Employment, (now under Directorate General of Training, Ministry of Skill Development and Entrepreneurship) Government of India, with technical assistance from the Govt. of the Federal Republic of Germany. The prime objective of this institute is to develop and provide instructional materials for various trades as per the prescribed syllabi under the Craftsman and Apprenticeship Training Schemes.

The instructional materials are created keeping in mind, the main objective of Vocational Training under NCVT/NAC in India, which is to help an individual to master skills to do a job. The instructional materials are generated in the form of Instructional Media Packages (IMPs). An IMP consists of Theory book, Practical book, Test and Assignment book, Instructor Guide, Audio Visual Aid (Wall charts and Transparencies) and other support materials.

The trade practical book consists of series of exercises to be completed by the trainees in the workshop. These exercises are designed to ensure that all the skills in the prescribed syllabus are covered. The trade theory book provides related theoretical knowledge required to enable the trainee to do a job. The test and assignments will enable the instructor to give assignments for the evaluation of the performance of a trainee. The wall charts and transparencies are unique, as they not only help the instructor to effectively present a topic but also help him to assess the trainee's understanding. The instructor guide enables the instructor to plan his schedule of instruction, plan the raw material requirements, day to day lessons and demonstrations.

In order to perform the skills in a productive manner instructional videos are embedded in QR code of the exercise in this instructional material so as to integrate the skill learning with the procedural practical steps given in the exercise. The instructional videos will improve the quality of standard on practical training and will motivate the trainees to focus and perform the skill seamlessly.

IMPs also deals with the complex skills required to be developed for effective team work. Necessary care has also been taken to include important skill areas of allied trades as prescribed in the syllabus.

The availability of a complete Instructional Media Package in an institute helps both the trainer and management to impart effective training.

The IMPs are the outcome of collective efforts of the staff members of NIMI and the members of the Media Development Committees specially drawn from Public and Private sector industries, various training institutes under the Directorate General of Training (DGT), Government and Private ITIs.

NIMI would like to take this opportunity to convey sincere thanks to the Directors of Employment & Training of various State Governments, Training Departments of Industries both in the Public and Private sectors, Officers of DGT and DGT field institutes, proof readers, individual media developers and coordinators, but for whose active support NIMI would not have been able to bring out this materials.

Chennai - 600 032

**R. P. DHINGRA
EXECUTIVE DIRECTOR**

ACKNOWLEDGEMENT

National Instructional Media Institute (NIMI) sincerely acknowledges with thanks for the co-operation and contribution extended by the following Media Developers and their sponsoring organisations to bring out this Instructional Material (**Trade Theory**) for the trade of **Fitter** under Production & Manufacturing Sector for ITIs.

MEDIA DEVELOPMENT COMMITTEE MEMBERS

Shri. M. Sampath	–	Training officer (Retd.) CTI, Chennai-32.
Shri. M. Sangarapandian	–	Training officer (Retd.) CTI, Chennai - 32
Shri. K. Kesavan	–	Asst. App. Advisor Junior (Retd) DET, Tamilnadu
Shri. C.C. Subramanian	–	Training officer (Retd.) Balamandir PHM ITI, Chennai - 17
Shri. A. Stephen	–	Instructor, St. John's ITI Manapparai Trichy District - 621 307
Shri. A. Chandraprakash	–	Vocational Instructor, NSTI, Hyderabad
Shri. K.B. Shivaramu	–	Junior Training officer Government ITI, Mysore - 570007
Shri. D.C. Nataraja	–	Junior Training officer Government ITI, Mysore - 570007
Shri. Milind Rasu	–	Instructor, Government ITI Aliganj, Lucknow
Shri. K. Srinivasa Rao	–	Joint Director, Co-ordinator, NIMI, Chennai - 32
Shri. G. Michael Johny	–	Assistant Manager, Co-ordinator, NIMI, Chennai - 32

NIMI records its appreciation for the Data Entry, CAD, DTP operators for their excellent and devoted services in the process of development of this Instructional Material.

NIMI also acknowledges with thanks the invaluable efforts rendered by all other NIMI staff who have contributed towards the development of this Instructional Material.

NIMI is also grateful to everyone who has directly or indirectly helped in developing this Instructional Material.

INTRODUCTION

TRADE THEORY

The manual of trade theory consists of theoretical information for the Second Semester Course of the Fitter Trade. The contents are sequenced according to the practical exercise contained in NSQF LEVEL - 5 syllabus on Trade practical. Attempt has been made to relate the theoretical aspects with the skill covered in each exercise to the extent possible. This correlation is maintained to help the trainees to develop the perceptual capabilities for performing the skills.

Module 1	Drilling	150 Hrs
Module 2	Fitting assembly	150 Hrs
Module 3	Turning	125 Hrs
Module 4	Basic Maintenance	75 Hrs
Module 5	In-plant training/Project work	50 Hrs
	Total	<u>550 Hrs</u>

The Trade Theory has to be taught and learnt along with the corresponding exercise contained in the manual on trade practical. The indications about the corresponding practical exercises are given in every sheet of this manual.

It will be preferable to teach/learn the trade theory connected to each exercise at least one class before performing the related skills in the shop floor. The trade theory is to be treated as an integrated part of each exercise.

The material is not for the purpose of self learning and should be considered as supplementary to class room instruction.

TRADE PRACTICAL

The trade practical manual is intended to be used in practical workshop. It consists of a series of practical exercises to be completed by the trainees during the Second Semester Course of the Fitter Trade supplemented and supported by instructions/ informations to assist in performing the exercises. These exercises are designed to ensure that all the skills in compliance with NSQF LEVEL - 5 syllabus are covered.

The manual is divided into five modules. The distribution of time for the practical in the five modules are given below.

The skill training in the shop floor is planned through a series of practical exercises centred around some practical object. However, there are few instances where the individual exercise does not form a part of project.

While developing the practical manual a sincere effort was made to prepare each exercise which will be easy to understand and carry out even by below average trainee. However the development team accept that there is a scope for further improvement. NIMI looks forward to the suggestions from the experienced training faculty for improving the manual.

CONTENTS

Lesson No.	Title of the Lesson	Page No.
Module 1: Drilling		
2.1.61	Drills	1
2.1.62	Drill angles	4
2.1.63 - 65	Drilling - Cutting speed, feed and r.p.m , drill holding devices	6
2.1.66	Counter sinking	9
2.1.67	Reamers	16
2.1.68 - 69	Screw thread and elements	22
2.1.70	Tap wrenches, removal of broken tap, studs	32
2.1.71	Dies and die stock	36
2.1.72 - 73	Drill troubles - Causes and remedy, drill kinds	40
2.1.74 - 75	Standard marking system for Grinding wheels	46
2.1.76	Radius/Fillet gauge, feeler gauge, hole gauge	55
2.1.77 - 78	Pig Iron	60
Module 2: Fitting assembly		
2.2.79 - 80	Necessity of Interchangeability in engineering field	63
2.2.81	Vernier height gauge	73
2.2.82	Wrought iron and plain carbon steels	75
2.2.83 - 85	Simple scrapers and scraping	81
2.2.86 - 88	Vernier micrometer, screw thread micrometer, graduation & reading	86
2.2.89	Dial test indicator, comparators, digital dial indicator	93
Module 3: Turning		
2.3.90	Safety to be observed while working on lathes	102
2.3.91	Lathe main parts	104
2.3.92	Feeding & thread cutting mechanism	110
2.3.93	Holding the job between centre and work with catch plate and dog	113
2.3.94	Simple description of facing and roughing tool	115
2.3.95	Nomenclature of single point cutting tools and multi point cutting tools	117
2.3.96	Tool selection based on different requirements	120
2.3.97	Necessity of grinding angles	123

Lesson No.	Title of the Lesson	Page No.
2.3.98	Lathe cutting speed and feed, use of coolants, lubricants	125
2.3.99	Chucks and chucking - the independent 4 jaw chuck	130
2.3.100	Face plate	136
2.3.101	Drilling	138
2.3.102	Boring & boring tools	139
2.3.103	Tool setting	141
2.3.104	Tool post	145
2.3.105	Lathe operation - Knurling	147
2.3.106	Standard tapers	150
2.3.107	Screw thread	154
2.3.108	Principle of cutting screw thread in centre lathe	158
2.3.109	Principle of chasing screw thread	161
	Module 4 : Basic Maintenance	
2.4.110	Total productive maintenance	168
2.4.111	Routine maintenance	170
2.4.112	Preventive maintenance	172
2.4.113	Inspection, types of inspection and gadgets for inspection	177
2.4.114	Lubrication survey	180
2.4.115	Causes for assembly failures and remedies	183
2.4.116	Assembly techniques	184

LEARNING / ASSESSABLE OUTCOME

On completion of this book you shall be able to

- **Produce components by different operations and check accuracy using appropriate measuring instrument. [Different Operations- Drilling, reaming, tapping, dieing., Appropriate measuring instruments - Vernier, screw gauge, micrometer.]**
- **Make different fit of components for assembling as per required tolerance observing principle of interchangeability and check for functionality. [Different fit-sliding, angular, step fit, 'T' fit, square fit and profile fit., Required tolerance; ± 0.04 mm, angular tolerace: 30 min]**
- **Produce components involving different operations on lathe observing standard procedure and check for accuracy. [Different operations - Facing, plain turning, step turning, parting, chamfering, shoulder turn, grooving, knurling, boring, taper turning, threading (external 'V' only.)]**
- **Plan & perform simple rapair, overhauling of different machines and check for functionality. [Different machines - Drill machine, power saw, bench grinder and lathe.]**

SYLLABUS

Second Semester

Duration: Six Month

Week No.	Ref. Learning Outcome	Professional Skills (Trade Practical) with Indicative hours	Professional Knowledge (Trade Theory)
27	Produce components by different operations and check accuracy using appropriate measuring instruments. [Different Operations-Drilling, Reaming, Taping, Dieing; Appropriate Measuring Instrument – Vernier, Screw Gauge, Micrometer]	61 Mark off and drill through holes. (5 hrs.) 62 Drill on M.S. flat. (1 hrs.) 63 File radius and profile to suit gauge (13 hrs.) 64 Sharpening of Drills. (1 hrs.) 65 Practice use of angular measuring instrument. (5 hrs.)	Drill- material, types, (Taper shank, straight shank) parts and sizes. Drill angle-cutting angle for different materials, cutting speed feed. R.P.M. for different materials. Drill holding devices material, construction and their uses.
28	-do-	66 Counter sink, counter bore and ream split fit (three piece fitting). (5 hrs.) 67 Drill through hole and blind holes. (2 hrs.) 68 Form internal threads with taps to standard size (through holes and blind holes). (3 hrs.) 69 Prepare studs and bolt. (15 hrs.)	Counter sink, counter bore and spot facing-tools and nomenclature, Reamer material, types (Hand and machine reamer), kinds, parts and their uses, determining hole size (or reaming), Reaming procedure. Screw threads: terminology, parts, types and their uses. Screw pitch gauge: material parts and uses. Taps British standard (B.S.W., B.S.F., B.A. & B.S.P.) and metric / BIS (course and fine) material, parts (shank body, flute, cutting edge).
29	-do-	70 Form external threads with dies to standard size. (10 hrs.) 71 Prepare nuts and match with bolts. (15 hrs.)	Tap wrench: material, parts, types (solid & adjustable types) and their uses removal of broken tap, studs (tap stud extractor). Dies: British standard, metric and BIS standard, material, parts, types, Method of using dies. Die stock: material, parts and uses.

30	-do-	72 File and make Step fit, angular fit, angle, surfaces (Bevel gauge accuracy 1 degree).(15 hrs.) 73 Make simple open and sliding fits. (10 hrs.)	Drill troubles: causes and remedy. Equality of lips, correct clearance, dead centre, length of lips. Drill kinds: Fraction, metric, letters and numbers, grinding of drill.
31	-do-	74 Enlarge hole and increase internal dia. (2 hrs.) 75 File cylindrical surfaces.(5 hrs.) 76 Make open fitting of curved profiles.(18 hrs.)	Grinding wheel: Abrasive, grade structures, bond, specification, use, mounting and dressing. Selection of grinding wheels. Bench grinder parts and use. Radius/fillet gauge, feeler gauge, hole gauge, and their uses, care and maintenance.
32	-do-	77 Correction of drill location by binding previously drilled hole.(5 hrs.) 78 Make inside square fit. (20 hrs.)	Pig Iron: types of pig Iron, properties and uses. Cast Iron: types, properties and uses.
33	Make different fit of components for assembling as per required tolerance observing principle of interchangeability and check for functionality. [Different Fit – Sliding, Angular, Step fit, 'T' fit, Square fit and Profile fit; Required tolerance: ± 0.04 mm, angular tolerance: 30 min.]	79 Make sliding „T. fit.(2 hrs.)	Interchangeability: Necessity in Engg, field definition, BIS. Definition, types of limit, terminology of limits and fits-basic size, actual size, deviation, high and low limit, zero line, tolerance zone Different standard systems of fits and limits. British standard system, BIS system
34	-do-	80 File fit- combined, open angular and sliding sides. (10 hrs.) 81 File internal angles 30minutes accuracy open, angular fit.(15 hrs.)	Method of expressing tolerance as per BIS Fits: Definition, types, description of each with sketch. Vernier height gauge: material construction, parts, graduations (English & Metric) uses, care and maintenance.
35-36	-do-	82 Make sliding fit with angles other than 90° .(25 hrs.)	Wrought iron- : properties and uses. Steel: plain carbon steels, types, properties and uses. Non-ferrous metals (copper, aluminum, tin, lead, zinc) properties and uses.

37	-do-	<p>83 Scrap on flat surfaces, curved surfaces and parallel surfaces and test. (5 hrs.)</p> <p>84 Make & assemble, sliding flats, plain surfaces. (15 hrs.)</p> <p>85 Check for blue math of bearing surfaces - both flat and curved surfaces by with worth method.(5hrs.)</p>	Simple scraper- circular, flat, half round, triangular and hook scraper and their uses. Blue matching of scraped surfaces (flat and curved bearing surfaces)
38	-do-	<p>86 File and fit combined radius and angular surface (accuracy ± 0.5 mm), angular and radius fit. (18 hrs.)</p> <p>87 Locate accurate holes & make accurate hole for stud fit.(2 hrs.)</p> <p>88 Fasten mechanical components / sub-assemblies together using screws, bolts and collars using hand tools. (5 hrs.)</p>	Vernier micrometer, material, parts, graduation, use, care and intenance. Calibration of measuring instruments. Introduction to mechanical fasteners and its uses. Screw thread micrometer: Construction, graduation and use.
39	-do-	<p>89 Make sliding fits assembly with parallel and angular mating surface. (± 0.04 mm) (25 hrs.)</p>	Dial test indicator, construction, parts, material, graduation, Method of use, care and maintenance. Digital dial indicator. Comparators- measurement of quality in the cylinder bores.
40	Produce components involving different operations on lathe observing standard procedure and check for accuracy. [Different Operations – facing, plain turning, step turning, parting, chamfering, shoulder turn, grooving, knurling, boring, taper turning, threading (external 'V' only)]	<p>90 Lathe operations-</p> <p>91 True job on four jaw chuck using knife tool.(5 hrs.)</p> <p>92 Face both the ends for holding between centers. (9 hrs.)</p> <p>93 Using roughing tool parallel turn ± 0.1 mm. (10 hrs.)</p> <p>94 Measure the diameter using outside caliper and steel rule.(1hrs.)</p>	Safely precautions to be observed while working on a lathe, Lathe specifications, and constructional features. Lathe main parts descriptions- bed, head stock, carriage, tail stock, feeding and thread cutting mechanisms. Holding of job between centers, works with catch plate, dog, simple description of a facing and roughing tool and their applications.
41	-do-	<p>95 Holding job in three jaw chuck.(2 hrs.)</p> <p>96 Perform the facing, plain turn, step turn, parting, deburr, chamfercorner, round the ends, and use form tools. (11 hrs.)</p>	Lathe cutting tools- Nomenclature ofsingle point & multipoint cutting tools, Tool selection based on different requirements and necessity of correct grinding, solid and tipped, throw away

		<p>97 Shoulder turn: square, filleted, beveled undercut shoulder, turning-filleted under cut, square beveled. (11 hrs.)</p> <p>98 Sharpening of -Single point Tools. (1 hrs.)</p>	<p>type tools, cutting speed and feed and comparison for H.S.S., carbide tools. Use of coolants and lubricants.</p>
42	-do-	<p>99 Cut grooves- square, round,V. groove. (10 hrs.)</p> <p>100 Make a mandrel-turn diameter to sizes. (5 hrs.)</p> <p>101 Knurl the job.(1 hrs.)</p> <p>102 Bore holes –spot face, pilot drill, enlarge hole using boring tools. (9 hrs.)</p>	<p>Chucks and chucking the independent four-jaw chuck. Reversible features of jaws, the back plate, Method of clearing the thread of the chuck-mounting and dismounting, chucks, chucking true, face plate, drilling - method of holding drills in the tail stock, Boring tools and enlargement of holes.</p>
43	-do-	<p>103 Make a bush step bore-cut recess, turn hole diameter to sizes.(5 hrs.)</p> <p>104 Turn taper (internal and external). (10 hrs.)</p> <p>105 Turn taper pins. (5 hrs.)</p> <p>106 Turn standard tapers to suit with gauge.(5 hrs.)</p>	<p>General turning operations- parallel or straight, turning. Stepped turning, grooving, and shape of tools for the above operations. Appropriate method of holding the tool on tool post or tool rest, Knurling: - tools description, grade, uses, speed and feed, coolant for knurling, speed, feed calculation. Taper – definition, use and method of expressing tapers. Standard tapers-taper, calculations morse taper.</p>
44	-do-	<p>107 Practice threading using taps, dies on lathe by hand. (2 hrs.)</p> <p>108 Make external „V. thread.(8 hrs.)</p> <p>109 Prepare a nut and match with the bolt.(15 hrs.)</p>	<p>Screw thread definition – uses and application. Square, worm, buttress, acme (non standard-screw threads), Principle of cutting screw thread in centre lathe –principle of chasing the screw thread – use of centre gauge,setting tool for cutting internal and external threads, use of screw pitch gauge for checking the screw thread.</p>
45-46	Plan & perform simple repair, overhauling of different machines and check for functionality. [Different Machines – Drill Machine, Power Saw, Bench Grinder and Lathe]	<p>110 Simple repair work: Simple assembly of machine parts from blue prints. (15 hrs.)</p> <p>111 Rectify possible assembly faults during assembly.(19 hrs.)</p> <p>112 Perform the routine maintenance with check list (10 hrs.)</p> <p>113 Monitor machine as per routine checklist (3 hrs.)</p> <p>114 Read pressure gauge, temperature gauge, oil level (1 hrs.)</p> <p>115 Set pressure in pneumatic system (2 hrs.)</p>	<p>Maintenance</p> <p>-Total productive maintenance - Autonomous maintenance -Routine maintenance -Maintenance schedule -Retrieval of data from machine manuals Preventive maintenance-objective and function of Preventive maintenance, section inspection. Visual and detailed, lubrication survey, system of symbol and colour coding. Revision, simple estimation of materials, use of handbooks and reference table. Possible causes for assembly failures and remedies.</p>

47	-do-	116 Assemble simple fitting using dowel pins and tap screw assembly using torque wrench. (25 hrs.)	Assembling techniques such as aligning, bending, fixing, mechanical jointing, threaded jointing, sealing, and torquing. Dowel pins: material, construction, types, accuracy and uses.
48-49		In-plant training / Project work 1 Pipe Fixture 2 Adjustable Clamp 3 Hermaphrodite/ Inside Caliper 4 Chuck Key	
50-51		Revision	
52		Examination	
<p>Copyright @ NIMI Not to be Republished</p>			

Drills

Objectives: At the end of this lesson you shall be able to

- state drilling
- state the necessity of drilling
- name the types of drills used
- identify the parts of a twist drill.

Drilling: Drilling is the production of cylindrical holes of definite diameters in workpieces by using a multi-point cutting tool called a 'drill'. It is the first operation done internally for any further operation.

Types of drills and their specific uses

Flat drill (Fig 1) : The earliest form of drill was the flat drill which is easy to operate, besides being inexpensive to produce. But it is difficult to hold during operation, and the chip removal is poor. Its operating efficiency is very low.

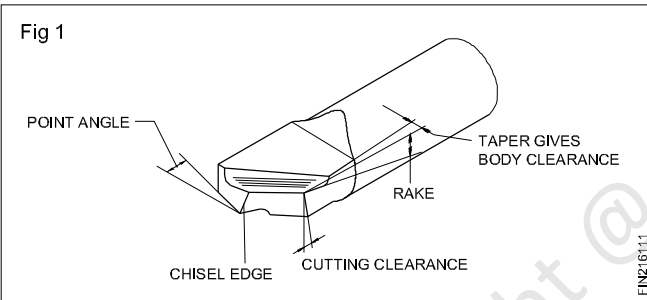

Twist drill : Almost all drilling operation is done using a twist drill. It is called a twist drill as it has two or more spiral or helical flutes formed along its length. The two basic types of twist drills are, parallel shank and taper shank. Parallel shank twist drills are available below 13mm size (Fig 2).

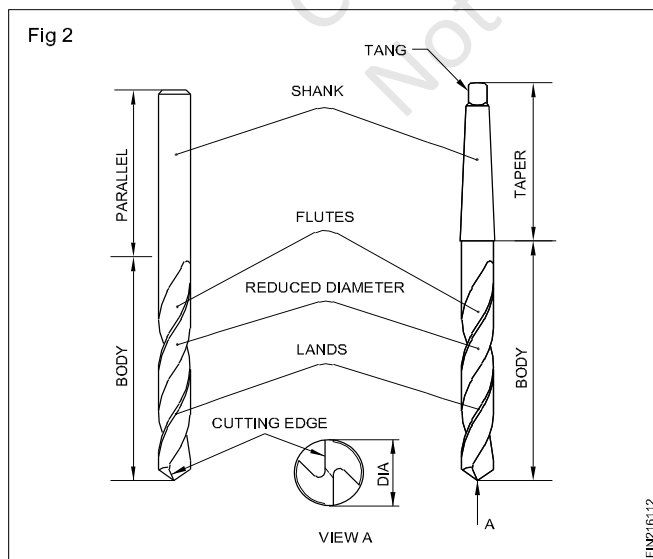

Parts of a twist drill : Drills are made out of high speed steel. The spiral flutes are machined at an angle of $27 \frac{1}{2}^\circ$ to its axis.

The flutes provide a correct cutting angle which provides an escape path for the chips. It carries the coolant to the cutting edge during drilling. (Fig 3)

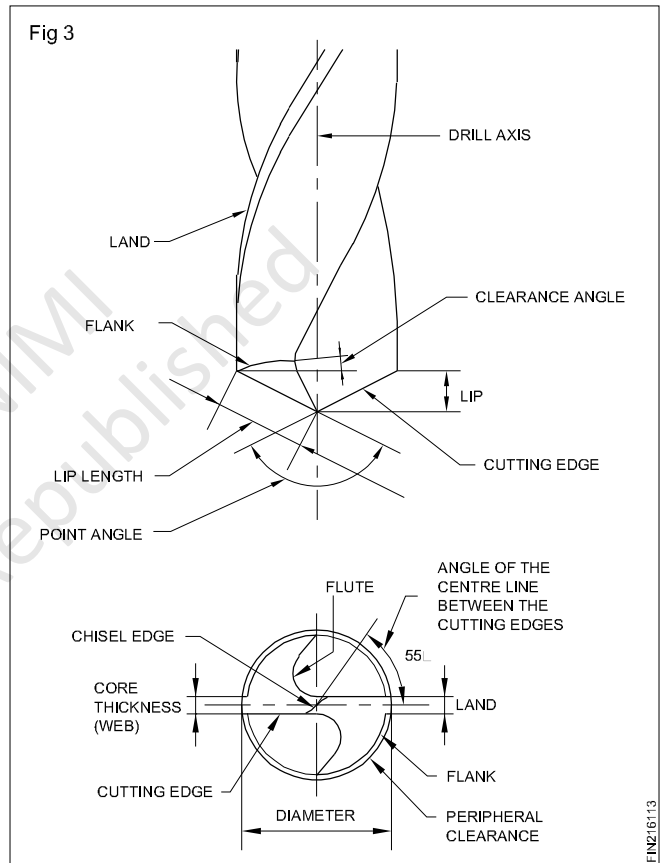

The portions left between the flutes are called 'lands'. The size of a drill is determined and governed by the diameter over the lands.

The point angle is the cutting angle, and for general purpose work, it is 118° . The clearance serves the purpose of clearing the back of the lip from fouling with the work. It is mostly 8° .

Deep hole drills

Deep hole drilling is done by using a type of drill known as 'D' bit (Fig 4)

Drills are made of high speed steel.

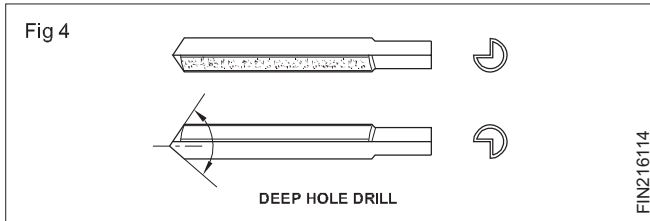

Drills are manufactured with varying helix angles for drilling different materials. General purpose drills have a standard helix angle of $27\ 1/2^\circ$. They are used on mild steel and cast iron. (Fig 5a)

A slow helix drill is used on materials like brass, gun metal, phosphor-bronze and plastics. (Fig 5b)

A quick helix drill is used for copper, aluminium and other soft metals (Fig 5c)

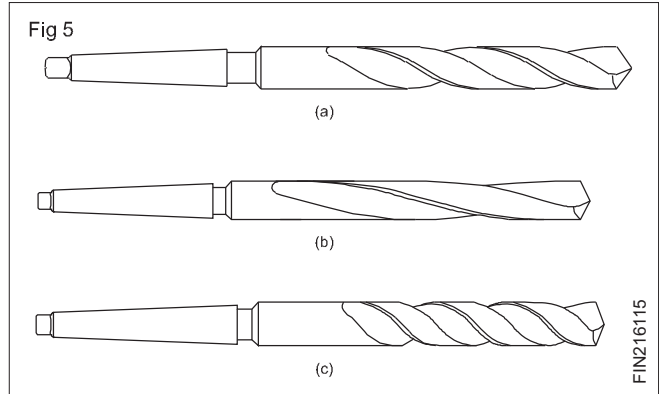

A quick helix drill should never be used on brass as it will 'dig in' and the workpiece may be thrown from the machine table.

Drill (Parts and functions)

Objectives: At the end of this lesson you shall be able to

- state the functions of drills
- identify the parts of a drill
- state the functions of each part of a drill.

Drilling is a process of making holes on workpieces. The tool used is a drill. For drilling, the drill is rotated with a downward pressure causing the tool to penetrate into the material. (Fig 1)

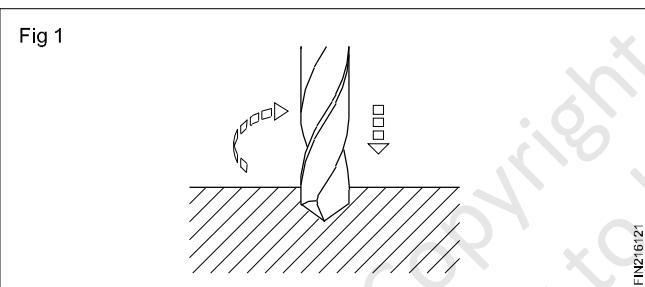

Parts of a Drill (Fig 2)

The various parts of a drill can be identified from figure 2.

Point

The cone shaped end which does the cutting is called the point. It consists of a dead centre, lips or cutting edges, and a heel.

Shank

This is the driving end of the drill which is fitted on to the machine. Shanks are of two types.

Taper shank, used for larger diameter drills, and straight shank, used for smaller diameter drills. (Fig 3)

Tang

This is a part of the taper shank drill which fits into the slot of the drilling machine spindle.

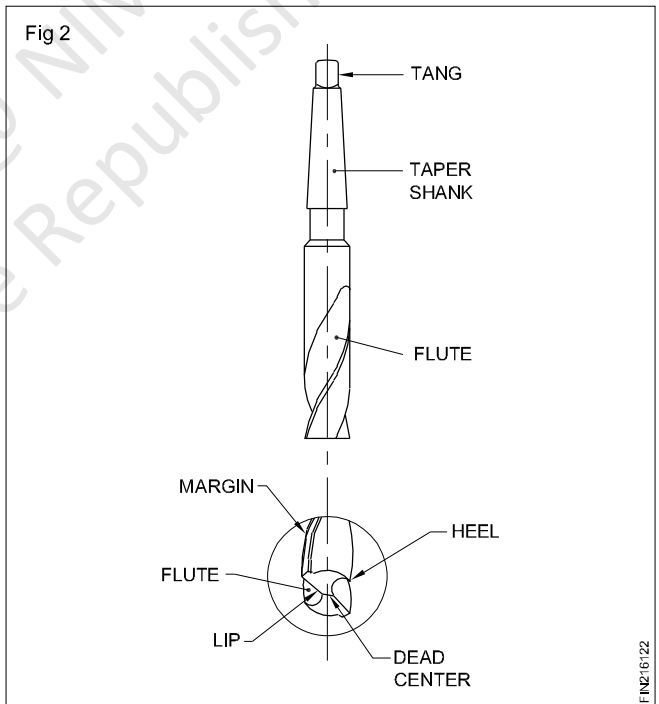

Body

The portion between the point and the shank is called the body of a drill.

The parts of the body are flute, land/margin, body clearance and web.

Flutes (Fig 3)

Flutes are the spiral grooves which run to the length of the drill. The flutes help

- To form the cutting edges
- To curl the chips and allow these to come out
- The coolant to flow to the cutting edge.

Land/Margin (Fig 3)

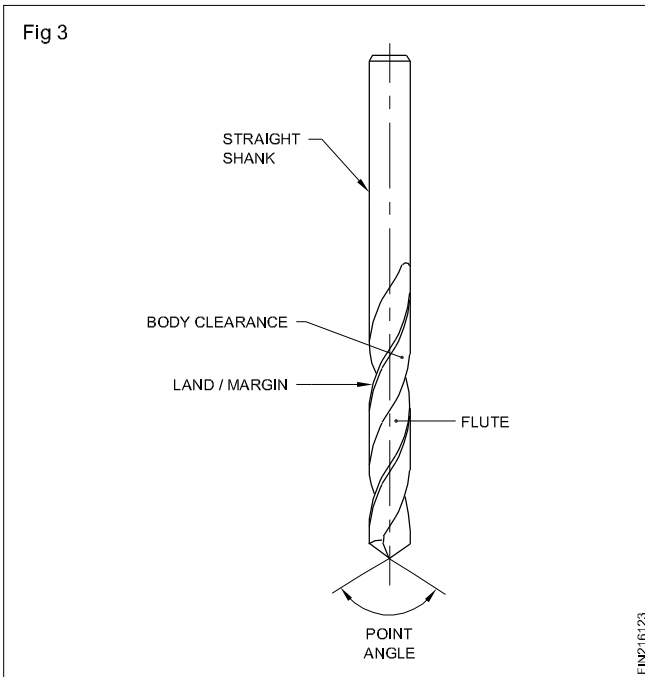

The land/margin is the narrow strip which extends to the entire length of the flutes.

The diameter of the drill is measured across the land/margin.

Body clearance (Fig 3)

Body clearance is the part of the body which is reduced in diameter to cut down the friction between the drill and the hole being drilled.

Web (Fig 4)

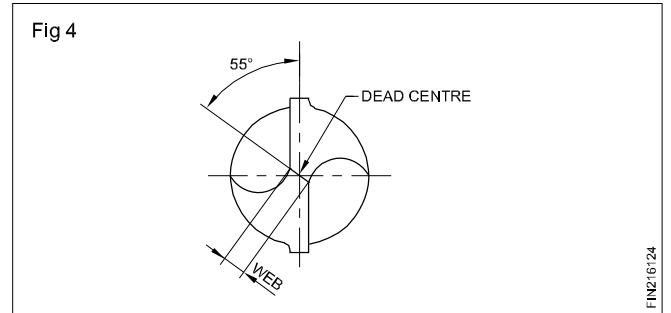

Web is the metal column which separates the flutes. It gradually increases in thickness towards the shank.

Drill angles

Objectives: At the end of this lesson you shall be able to

- identify the various angles of a twist drill
- state the functions of each angle
- list the types of helix for drills as per ISI
- distinguish the features of different types of drills
- designate drills as per ISI recommendations.

Like all cutting tools the drills are provided with certain angles for efficiency in drilling.

Drill angles

They are different angles for different purposes. They are listed below.

Point angle, helix angle, rake angle, clearance angle and chisel edge angle.

Point angle/ cutting angle (Fig 1)

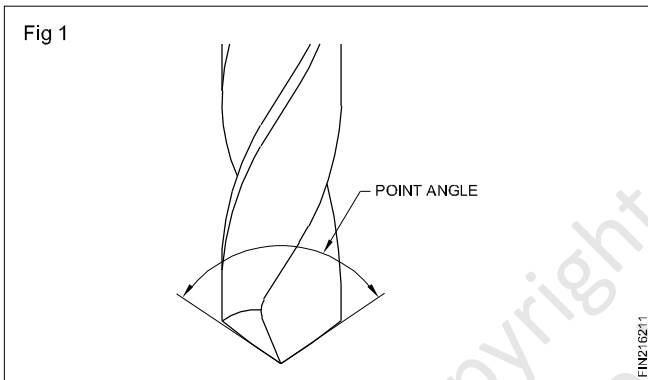

The point angle of a general purpose (standard) drill is 118°. This is the angle between the cutting edges (lips). The angle varies according to the hardness of the material to be drilled. (Fig 1)

Helix angle (Figs 2,3 and 4)

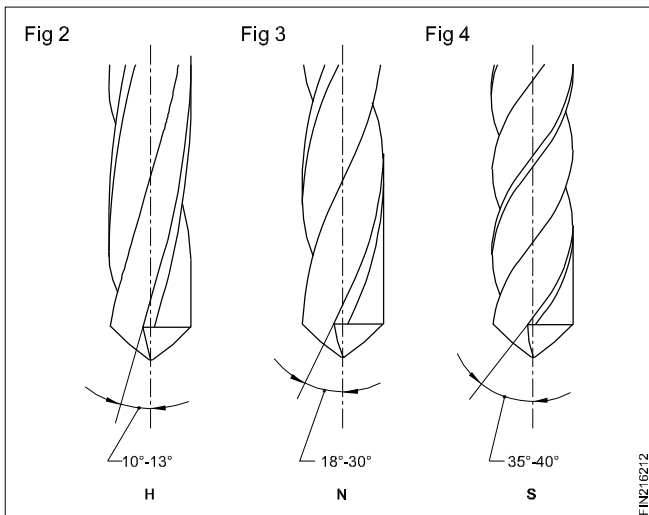

Twist drills are made with different helix angles. The helix angle determines the rake angle at the cutting edge of the twist drill.

The helix angles vary according to the material being drilled. According to indian standards, three types of drills are used for drilling various materials.

- Type N - For normal low carbon steel.
- Type H - For hard and tenacious materials.
- Types S - For soft and tough materials.

The type of drill used for general purpose drilling work is type N.

Rake angle (Fig 5)

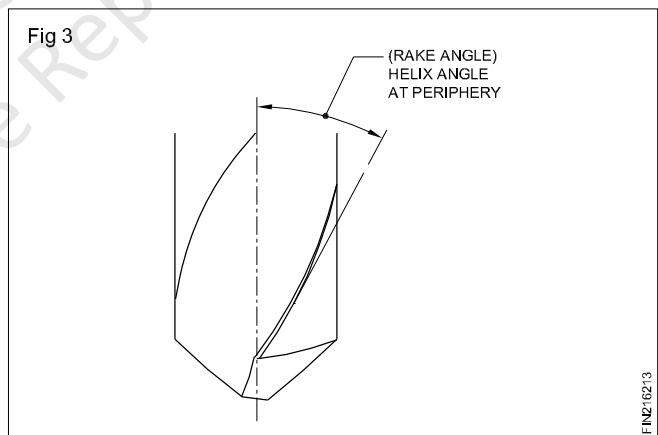

Rake angle is the angle of flute (helix angle).

Clearance angle (Fig 6)

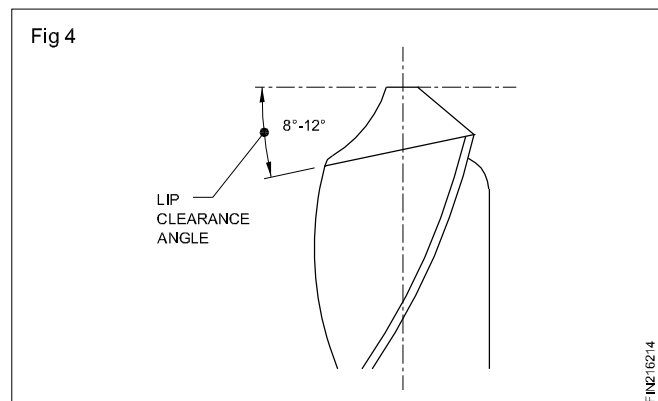

The clearance angle is meant to prevent the friction of the tool behind the cutting edge. This will help in the penetration of the cutting edges into the material. If the clearance angle is too much, the cutting edges will be weak, and if it is too small, the drill will not cut.

Chisel edge angle/web angle (Fig 7)

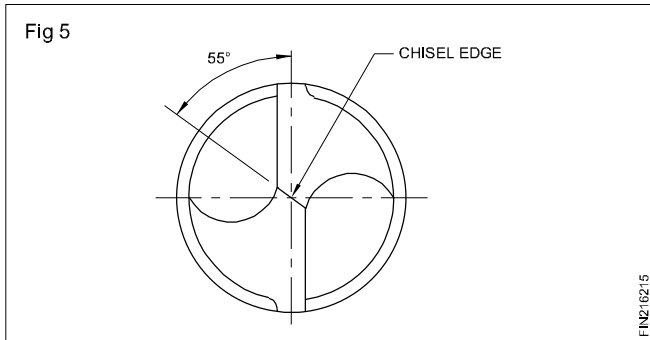

This is the angle between the chisel edge and the cutting lip.

Designation of drills

Twist drills are designated by the

- Diameter
- Tool type
- Material

Example

A twist drill of 9.50 mm dia. of tool type 'H' for right hand cutting and made from HSS is designated as:

Twist drill 9.50 - H - IS5101 - HS

where H = tool type

IS5101 = IS Number

HS = tool material

9.5 = diameter of the drill.

If the tool type is not indicated in the designation, it should be taken as type 'N' tool.

DRILLS FOR DIFFERENT MATERIALS

Recommended drills								
Material to be drilled	Point angle	Helix angle			Material to be drilled	Point angle	Helix angle	
		d=3.2-5	5-10	10-			d=3.5-5	5-
Steel and cast steel up to 70 kgf/mm ² strength Gray cast iron Malleable cast iron Brass German silver, nickel.					Copper (up to 30 mm drill diameter) Al-alloys, forming curly chips Celluloid			
		22°	25°	30°			35°	40°
Brass, CuZn 40					Austenitic steels Magnesium alloys			
		12°	13°	13°			12°	13°
Steel and cast steel 70...120 Kgf/mm ²					Moulded plastics (with thickness s>d)			
		22°	25°	30°			35°	40°
Stainless steel; Copper (drill diameter more than 30 mm) Al-alloy, forming short broken chips					Moulded plastics, with thickness s<d Laminated plastics, hard rubber (ebonite) marble, slate, coal			
		22°	25°	30°			12°	13°
					Zinc alloys			
							35°	40°

Drilling - Cutting speed, feed and r.p.m , drill holding devices

Objectives: At the end of this lesson you shall be able to

- **define cutting speed**
- **state the factors for determining the cutting speed**
- **differentiate between cutting speed and rpm**
- **determine r.p.m/spindle speed**
- **select r.p.m for drill sizes from the tables.**

For a drill to give a satisfactory performance, it must operate at the correct cutting speed and feed.

Cutting speed is the speed at which the cutting edge passes over the material while cutting, and is expressed in metres per minute.

Cutting speed is also sometimes stated as surface speed or peripheral speed.

The selection of the recommended cutting speed for drilling depends on the materials to be drilled, and the tool material.

Tool manufacturers usually provide a table of cutting speeds required for different materials.

The recommended cutting speeds for different materials are given in the Table 1. Based on the cutting speed recommended, the r.p.m, at which a drill has to be driven is determined.

TABLE 1

Recommended cutting speeds

Materials being drilled (HSS Tool)	
Aluminium	70 - 100
Brass	35 - 50
Bronze(phosphor)	20 - 35
Cast iron (grey)	25 - 40
Copper	35 - 45
Steel (medium carbon/mild steel)	20 - 30
Steel (alloy, high tensile)	5 - 8
Thermosetting plastic (low speed due to abrasive properties)	20 - 30

Cutting speed calculation

$$\text{Cutting speed (V)} = \frac{\pi \times d \times n}{1000} \text{ m/min}$$

$$r.p.m.(n) = \frac{V \times 1000}{d \times \pi}$$

n - r.p.m.

v - Cutting speed in m/min.

d - diameter of the drill in mm.

$\pi = 3.14$

Examples

Calculate the r.p.m for a high speed steel drill $\varnothing 24$ to cut mild steel.

The cutting speed for mild steel is taken as 30 m/min from the table.

$$n = \frac{1000 \times 30}{3.14 \times 24} = 398 \text{ r.p.m}$$

It is always preferable to set the spindle speed to the nearest available lower range.

The r.p.m. will differ according to the diameter of the drills. The cutting speed being the same, larger diameter drills will have lesser r.p.m and smaller diameter drills will have higher r.p.m.

The recommended cutting speeds are achieved only by actual experiment.

Feed in drilling

Objectives: At the end of this lesson you shall be able to

- **state what is meant by feed**
- **state the factors that contribute to an efficient feed rate.**

Feed is the distance (X) a drill advances into the work in one complete rotation. (Fig 1)

Feed is expressed in hundredths of a millimeter.

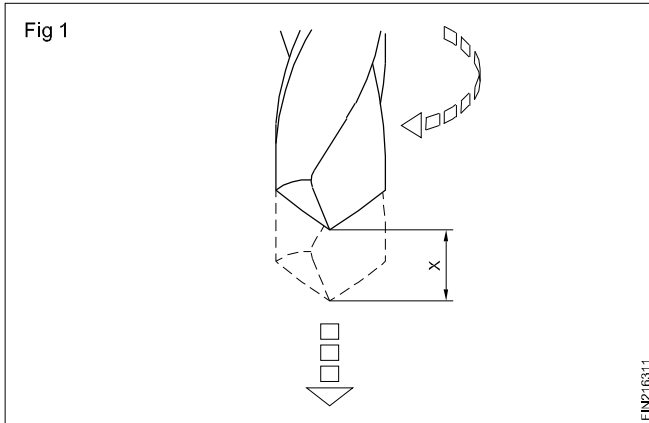

Example - 0.040mm/ rev

The rate of feed is dependant up on a number of factors.

- The finish required
- Type of drill (drill material)
- Material to be drilled

Factors like rigidity of the machine, holding of the work-piece and the drill, will also have to be considered while determining the feed rate. If these are not to the required standard, the feed rate will have to be decreased.

It is not possible to suggest a particular feed rate taking all the factors into account.

The table gives the feed rate which is based on the average feed values suggested by the different manufacturers of drills. (Table 1)

TABLE 1

Drill diameter (mm) H.S.S	Rate of feed (mm/rev)
1.0 - 2.5	0.040 - 0.060
2.6 - 4.5	0.050 - 0.100
4.6 - 6.0	0.075 - 0.150
6.1 - 9.0	0.100 - 0.200
9.1 - 12.0	0.150 - 0.250
12.1 - 15.0	0.200 - 0.300
15.1 - 18.0	0.230 - 0.330
18.1 - 21.0	0.260 - 0.360
21.1 - 25.0	0.280 - 0.380

Too coarse a feed may result in damage to the cutting edges or breakage of the drill.

Too slow a rate of feed will not bring improvement in surface finish but may cause excessive wear of the tool point, and lead to chattering of the drill.

For optimum results in the feed rate while drilling, it is necessary to ensure the drill cutting edges are sharp. Use the correct type of cutting fluid.

Drill-holding devices

Objectives: At the end of this lesson you shall be able to

- name the different types of drill-holding devices
- state the features of drill chucks
- state the functions of drill sleeves
- state the function of drift.

For drilling holes on materials, the drills are to be held accurately and rigidly on the machines.

The common drill-holding devices are drill chucks, sleeves and sockets.

Drill chucks: Straight shank drills are held in drill chucks. (Fig 1A) For fixing and removing drills, the chucks are provided either with a pinion and key or a knurled ring.

The drill chucks are held on the machine spindle by means of an arbor (Fig 1B) fitted on the drill chuck.

Taper sleeves and sockets (Fig 2): Taper shank drills have a Morse taper.

Sleeves and sockets are made with the same taper so that the taper shank of the drill, when engaged, will give a good wedging action. Due to this reason Morse tapers are called self-holding tapers.

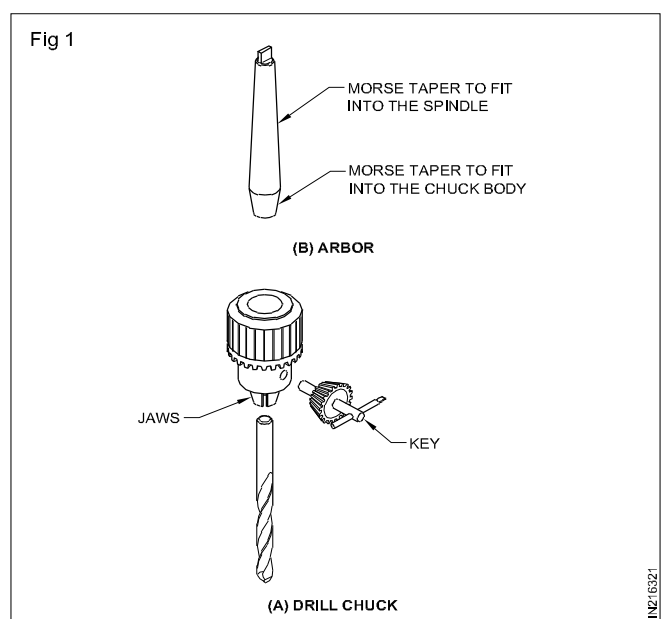

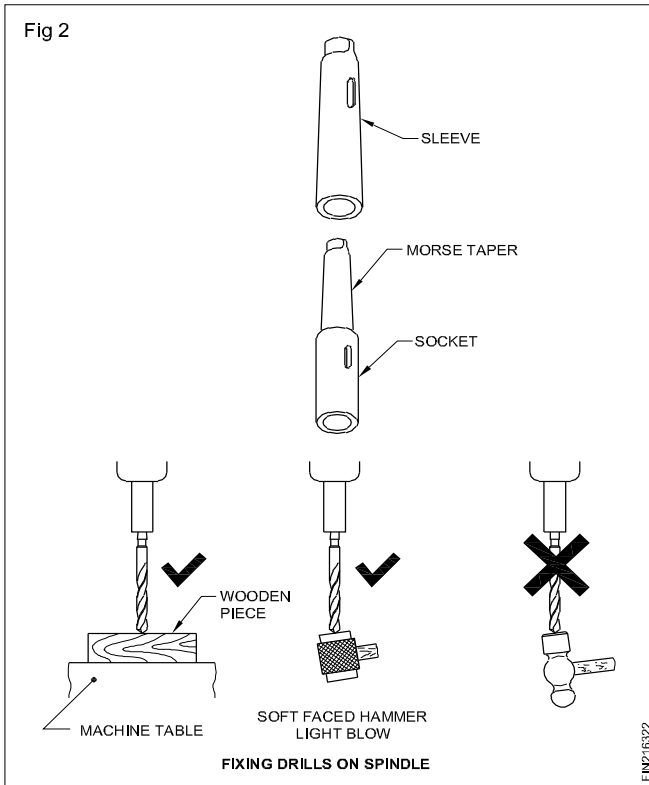

The drills are provided with five different sizes of Morse tapers, and are numbered from MT 1 to MT 5.

In order to make up the difference in sizes between the shanks of the drills and the bore of machine spindles, sleeves of different sizes are used. When the drill taper shank is bigger than the machine spindle, taper sockets are used. (Fig 2)

While fixing the drill in a socket or sleeve, the tang portion should align in the slot. This will facilitate the removal of the drill or sleeve from the machine spindle.

Use a drift to remove drills and sockets from the machine spindle. (Fig 3)

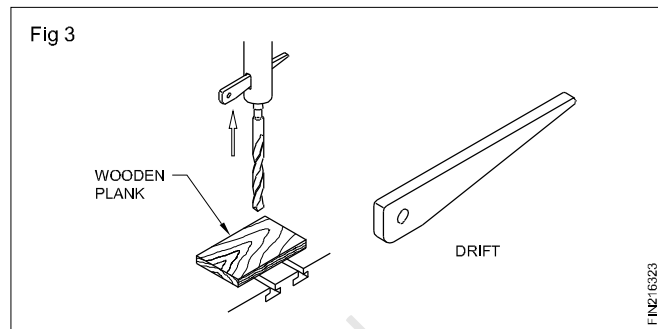

While removing the drill from the sockets/sleeves don't allow it to fall on the table or jobs.

Drill chucks are made from special alloy steel
Drill sleeves are made from case hardened steel

Counter sinking

Objectives: At the end of this lesson you shall be able to

- state countersinking
- list the purposes of countersinking
- state the angles of countersinking for the different applications
- name the different types of countersinks
- distinguish between Type A and Type B counter sink holes.

What is countersinking?

Countersinking is an operation of bevelling the end of a drilled hole. The tool used is called a countersink.

Countersinking is carried out for the following purposes:

- To provide a recess for the head of a countersink screw, so that it is flush with the surface after fixing (Fig 1)

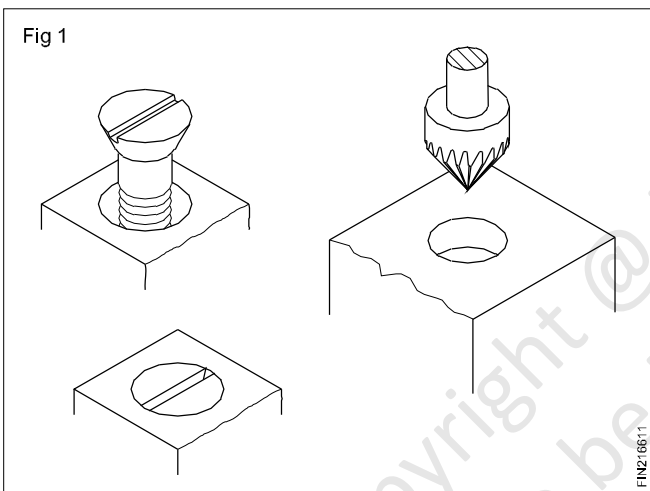

- To deburr a hole after drilling
- For accommodating countersink rivet heads
- To chamfer the ends of holes for thread cutting and other machining processes.

Angles for countersinking

Countersinks are available in different angles for different uses.

- 75° countersink riveting
- 80° countersink self tapping screws
- 90° countersink head screws and deburring
- 120° chamfering ends of holes to be threaded or other machining processes.

Countersinks

Countersinks of different types are available.

The commonly used countersinks have multiple cutting edges and are available in taper shank and straight shank. (Fig 2)

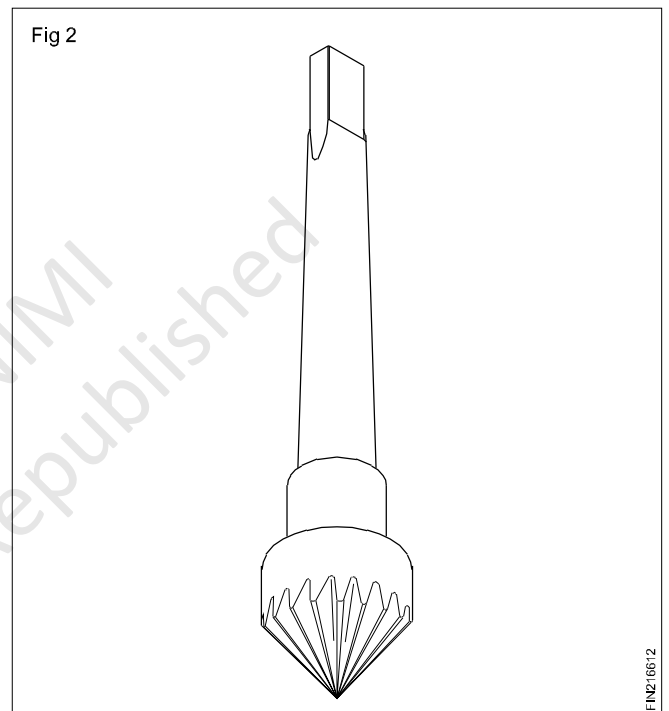

For countersinking small diameter holes special countersinks with two or one flute are available. This will reduce the vibration while cutting.

Countersinks with Pilot (Fig 3)

For precision countersinking, needed for machine tool assembling and after machining process, countersinks with pilots are used.

They are particularly useful for heavy duty work.

The pilot is provided at the end for guiding the countersink concentric to the hole.

Countersinks with pilots are available with interchangeable and solid pilots.

Countersink hole sizes

The countersink holes according to Indian Standard IS 3406 (Part 1) 1986 are of four types: Type A, Type B, Type C and Type E.

Fig 3

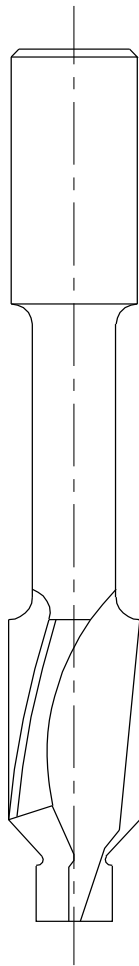

FIN216613

Type A is suitable for slotted countersink head screws, cross recessed and slotted raised countersink head screws.

These screws are available in two grades i.e. medium and fine.

The dimensions of various features of the Type 'A' countersink holes, and the method of designation are given in Table 1.

Type 'B' countersink holes are suitable for countersink head screws with hexagon socket.

The dimensions of the various features and the method of designation are given in Table II.

Type 'C' countersink holes are suitable for slotted raised countersink (oval) head tapping screws and for slotted countersink (flat) head tapping screws.

The dimension of the various features and the method of designation are given in Table III.

Type 'E' countersinks are used for slotted countersink bolts used for steel structures.

The dimensions of the various features and the method of designation are given in Table IV.

TABLE I

Dimensions and designation of countersink - Type A according to IS 3406 (Part 1) 1986

Fig 4

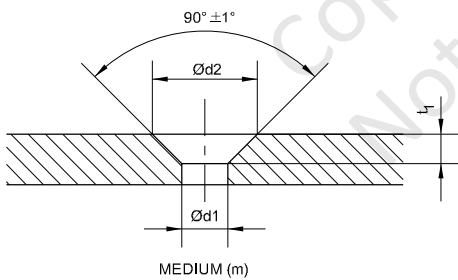

MEDIUM (m)

FIN216614

Fig 5

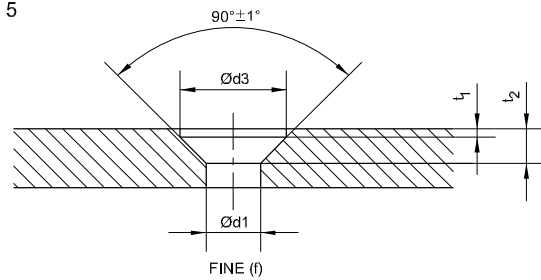

FINE (f)

FIN216615

TABLE I

For Nominal Size		1	1.2	(1.4)	1.6	(1.8)	2	2.5	3	3.5	4	(4.5)
Medium Series (m)	d1 H13	1.2	1.4	1.6	1.8	2.1	2.4	2.9	3.4	3.9	4.5	5
	d2 H13	2.4	2.8	3.3	3.7	4.1	4.6	5.7	6.5	7.6	8.6	9.5
	t1 ³	0.6	0.7	0.8	0.9	1	1.1	1.4	1.6	1.9	2.1	2.3
Fine Series (f)	d1 H12	1.1	1.3	1.5	1.7	2	2.2	2.7	3.2	3.7	4.3	4.8
	d3 H12	2	2.5	2.8	3.3	3.8	4.3	5	6	7	8	9
	t1 ³	0.7	0.8	0.9	1	1.2	1.2	1.5	1.7	2	2.2	2.4
	t2 + 0.1 0	0.2	0.15	0.15	0.2	0.2	0.15	0.35	0.25	0.3	0.3	0.3

For Nominal Size		5	6	8	10	12	(14)	16	(18)	20
Medium Series (m)	d1 H13	5.5	6.6	9	11	13.5	15.5	17.5	20	22
	d2 H13	10.4	12.4	16.4	20.4	23.9	26.9	31.9	36.4	40.4
	t1 ³	2.5	2.9	3.7	4.7	5.2	5.7	7.2	8.2	9.2
Fine Series (f)	d1 H12	5.3	6.4	8.4	10.5	13	15	17	19	21
	d3 H12	10	11.5	15	19	23	26	30	34	37
	t1 ³	2.6	3	4	5	5.7	6.2	7.7	8.7	9.7
	t2 + 0.1 0	0.2	0.45	0.7	0.7	0.7	0.7	1.2	1.2	1.7

Note 1 : Size shown in brackets are of second preference.

Note 2 : Clearance hole d1 according to medium and fine series of IS : 1821 ' Dimensions for clearance holes for bolts and screws (second revision)'

Designation : A countersink Type A with clearance hole of fine (f) series and having nominal size 10 shall be designated as – Countersink A f 10 - IS : 3406.

TABLE II

Dimensions and designation of countersink - Type B according to IS 3406 (Part 1) 1986

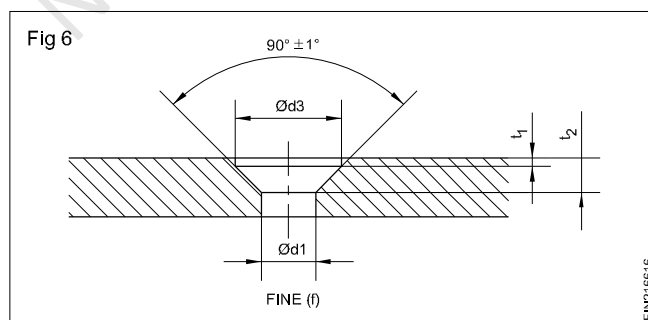

For Nominal Size		3	4	5	6	8	10	12	(14)	16	(18)	20	22 24
Fine Series (f)	d1 H12	3.2	4.3	5.3	6.4	8.4	10.5	13	15	17	19	21	23 25
	d2 H12	6.3	8.3	10.4	12.4	16.5	20.5	25	28	31	34	37	48.2 52
	t1 ³	1.7	2.4	2.9	3.3	4.4	5.5	6.5	7	7.5	8	8.5	13.1 14
	t2 + 0.1	0.2	0.3			0.4	0.5					1	

Note 1: Sizes shown in brackets are of second preference.

Note 2: Clearance hole d1 according to medium and fine series of IS : 1821- 1982.

Designation : A countersink Type B with clearance hole of fine (f) series and having nominal size 10 shall be designated as – Countersink B f 10 - IS : 3406.

TABLE III

Dimensions and designation of countersink - Type C according to IS 3406 (Part 1) 1986

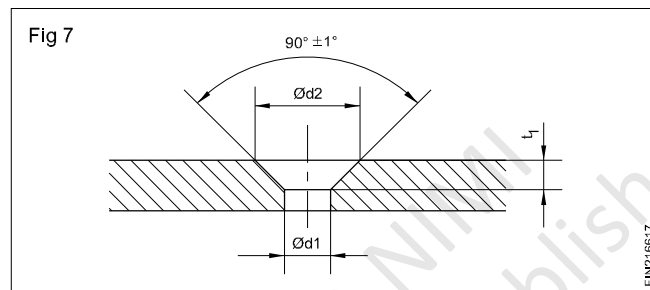

For Screw Size No.	(0)	(1)	2	(3)	4	(5)	6	(7)	8	10	(12)	14	(16)
d1 H12	1.6	2	2.4	2.8	3.1	3.5	3.7	4.2	4.5	5.1	5.8	6.7	8.4
d2 H12	3.1	3.8	4.6	5.2	5.9	6.6	7.2	8.1	8.7	10.1	11.4	13.2	16.6
t1 ³	0.9	1.1	1.3	1.5	1.7	1.9	2.1	2.3	2.6	3	3.4	3.9	4.9

Note : Sizes given in brackets are of second preference.

Designation : A countersink Type C for screw size 2 shall be designated as – Countersink C 2 - IS : 3406.

TABLE IV

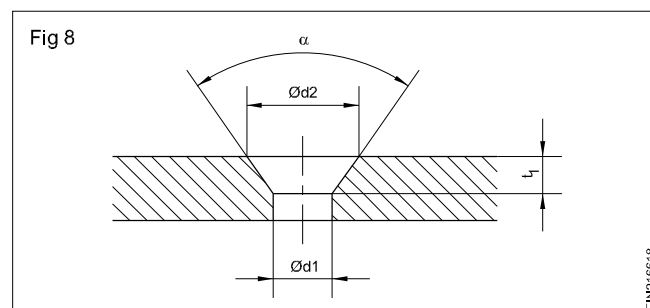

Dimension and designation of countersink - Type E according to IS 3406 (Part 1) 1986

For Nominal No.	10	12	16	20	22	24
d1 H12	10.5	13	17	21	23	25
d2 H12	19	24	31	34	37	40
t1 ³	5.5	7	9	11.5	12	13
$\alpha \pm 1^\circ$	75°			60°		
Note: Clearance hole d_1 according to fine series of IS : 1821 - 1982						

Designation : A countersink Type E for nominal size 10 shall be designated as – Countersink E 10 - IS : 3406.

Methods of representing countersink holes in drawings

Countersink hole sizes are identified by code designation or using dimension.

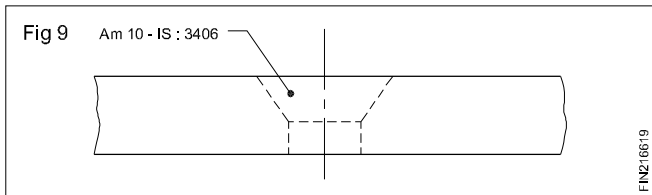

Use of code designation

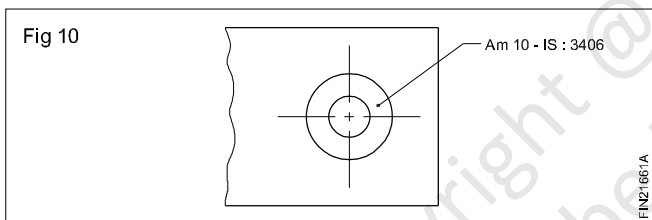

Use of dimension

The dimension of the countersink can be expressed by the diameter of the countersink and the depth of the countersink.

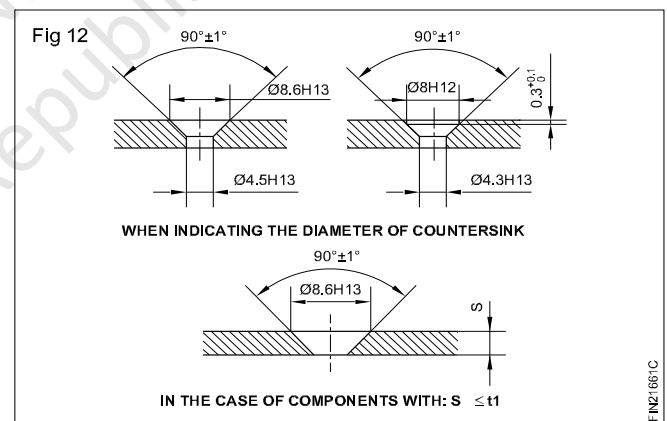
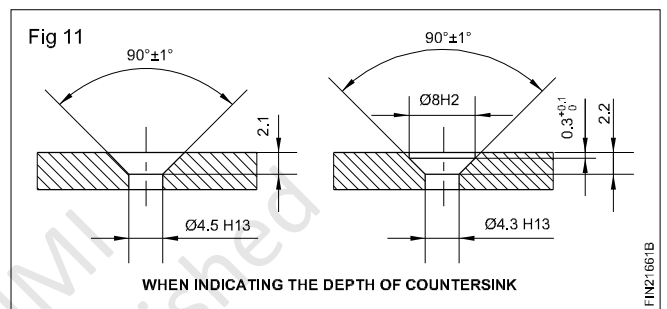

Counterboring and spot facing

Objectives: At the end of this lesson you shall be able to

- differentiate counterboring and spot facing
- state the types of counterbores and their uses
- determine the correct counterbore sizes for different holes.

Counterboring

Counterboring is an operation of enlarging a hole to a given depth, to house heads of socket heads or cap screws with the help of a counterbore tool. (Fig 1)

Counterbore (Tool)

The tool used for counterboring is called a counterbore. (Fig 2) Counterbores will have two or more cutting edges.

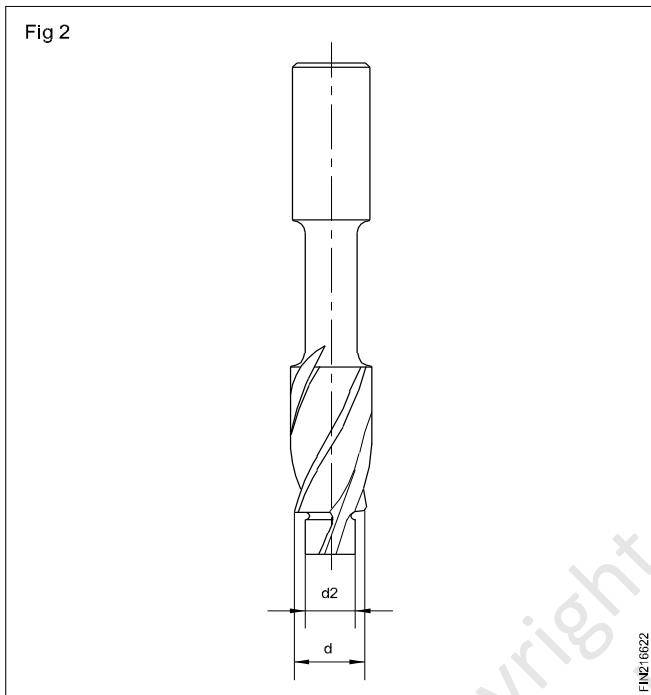
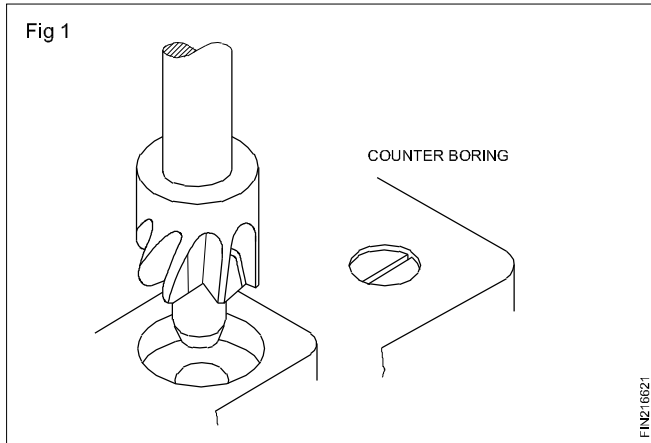

At the cutting end, a pilot is provided to guide the tool concentric to the previously drilled hole. The pilot also helps to avoid chattering while counterboring. (Fig 3)

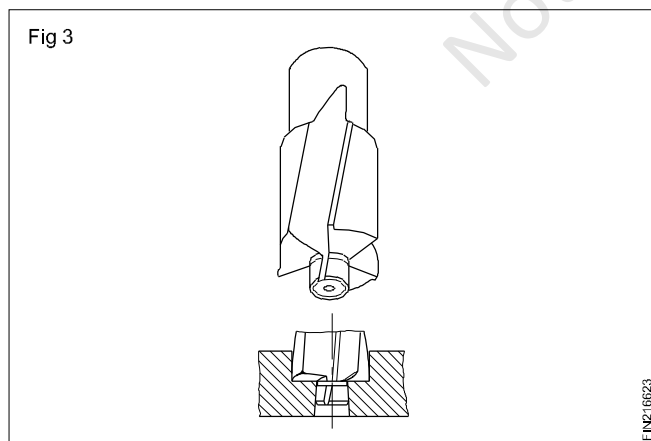

Counterbores are available with solid pilots or with interchangeable pilots. The interchangeable pilot provides flexibility of counterboring on different diameters of holes.

Spot facing

Spot facing is a machining operation for producing a flat seat for bolt head, washer or nut at the opening of a drilled hole. The tool is called a spot facer or a spot facing tool. Spot facing is similar to counterboring, except that it is shallower. Tools that are used for counterboring can be used for spot facing as well. (Fig 4)

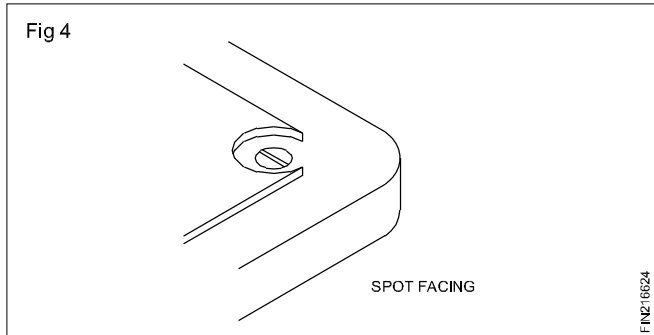

Spot facing is also done by fly cutters by end-cutting action. The cutter blade is inserted in the slot of the holder, which can be mounted on to the spindle. (Fig 5)

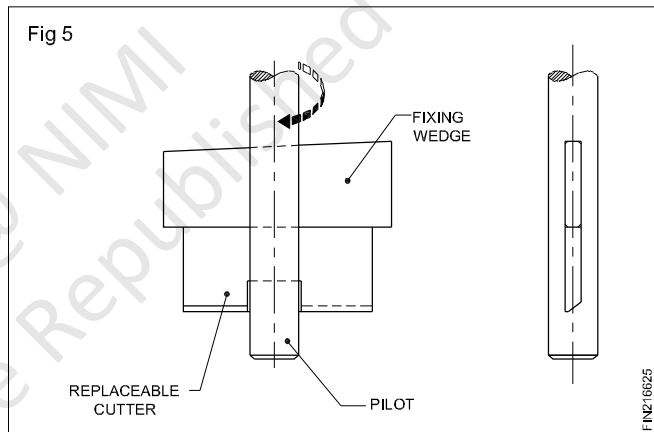

Counterbore sizes and specification

Counterbore sizes are standardised for each diameter of screws as per BIS.

There are two main types of counterbores. Type H and Type K.

The type H counterbores are used for assemblies with slotted cheese head, slotted pan head and cross recessed pan head screws. The type K counterbores are used in assemblies with hexagonal socket head capscrews.

For fitting different types of washers the counterbore standards are different in Type H and Type K.

The clearance hole d_1 are of two different grades i.e. medium (m) and fine (f) and are finished to H13 and H12 dimensions.

The table given below is a portion from IS 3406 (Part 2) 1986. This gives dimensions for Type H and Type K counterbores.

Dimensions for H and K Type counter bores

While representing counterbores in drawings, counterbores can be indicated either by code designation or using the dimensions.

Counterbore and Clearance Hole Sizes for Different Sizes of Screws

Table - 1

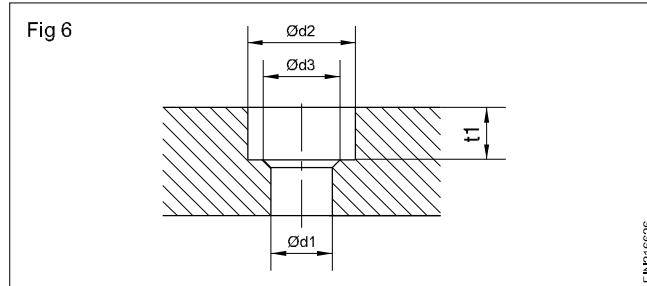

For Nominal size	1	1.2	1.4	1.6	1.8	2	2.5	3	(3.5)	4	5	6	8	10	12	(14)	16	18	20	22	24	27	30	33	36		
Medium (m) H13	1.2	1.4	1.6	1.8	2.1	2.4	2.9	3.4	3.9	4.5	5.5	6.6	9	11	13.5	15.5	17.5	20	22	24	26	30	33	36	39		
fine (f) H12	1.1	1.3	1.5	1.7	2	2.2	2.7	3.2	3.7	4.3	5.3	6.4	8.4	10.5	13	15	17	19	21	23	25	-	-	-	-		
d2 H13	2.2	2.5	2.8	3.3	3.8	4.3	5	6	6.5	8	10	11	15	18	20	24	26	30	33	36	40	43	48	53	57		
d3	-	-	-	-	-	-	-	-	-	-	-	-	-	-	15.5	17.5	19.5	22	24	26	28	33	36	39	42		
Type H t1	0.8	0.9	1	1.2	1.5	1.6	2	2.4	2.9	3.2	4	4.7	6	7	8	9	10.5	11.5	12.5	13.5	14.5	-	-	-	-		
Type K	-	-	1.6	1.8	-	2.3	2.9	3.4	-	4.6	5.7	6.8	9	11	13	15	17.5	19.5	21.5	23.5	25.5	28.5	32	35	38		
Tolerances	+0.1 0			+0.2 0				+0.4 0						+0.6 0													
Note : Sizes given in brackets are of second preference. For details refer IS : 3406 (Part2) 1986.																											

Using code designation (Fig 7)

Using dimensions (Fig 8)

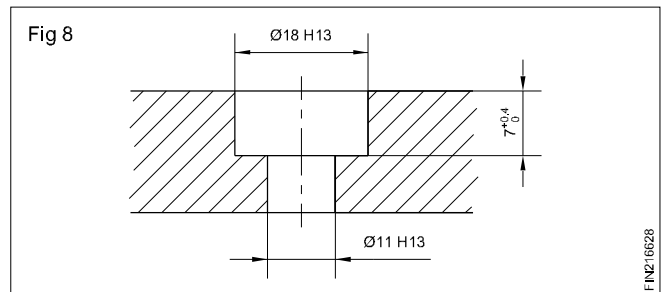
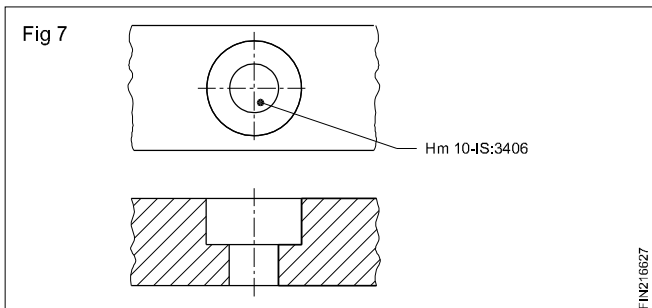

Reamers

Objectives: At the end of this lesson you shall be able to

- state the use of reamers
- state the advantages of reaming
- distinguish between hand and machine reaming
- name the elements of a reamer and state their functions.

What is a reamer?

A reamer is a multipoint cutting tool used for enlarging by finishing previously drilled holes to accurate sizes. (Fig 1)

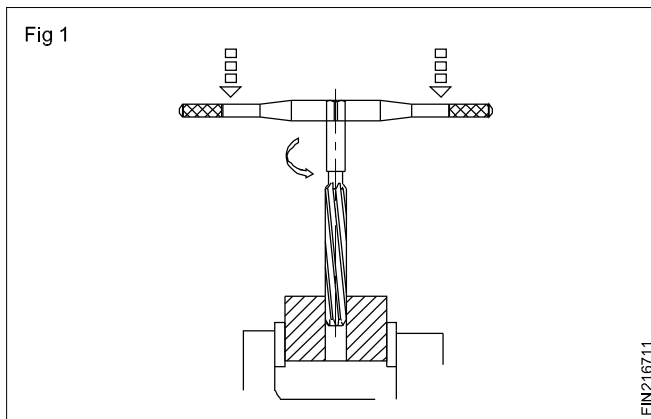

Advantages of 'reaming'

Reaming produces

High quality surface finish

Dimensional accuracy to close limits.

Also small holes which cannot be finished by other processes can be finished.

Classification of reamers

Reamers are classified as hand reamers and machine reamers. (Figs 2a and 2b)

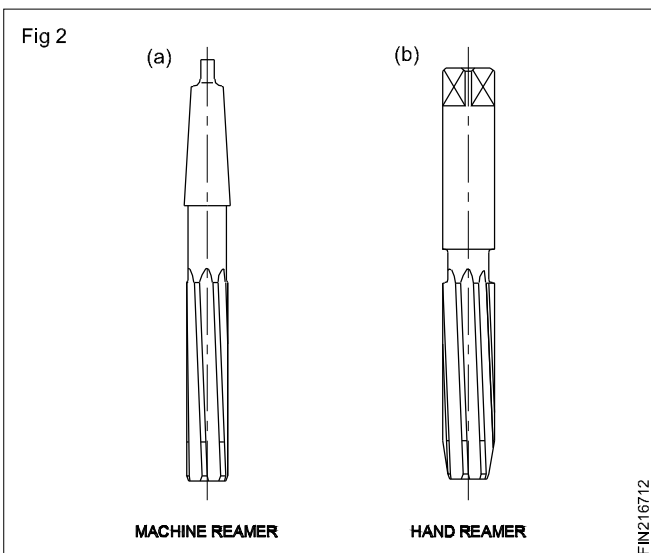

Reaming by using hand reamers is done manually for which great skill is needed.

Machine reamers are fitted on spindles of machine tools and rotated for reaming.

Machine reamers are provided with morse taper shanks for holding on machine spindles.

Hand reamers have straight shanks with 'square' at the end, for holding with tap wrenches. (Figs 2 (a) and (b))

Parts of a hand reamer

The parts of a hand reamer are listed hereunder. Refer to Fig 3.

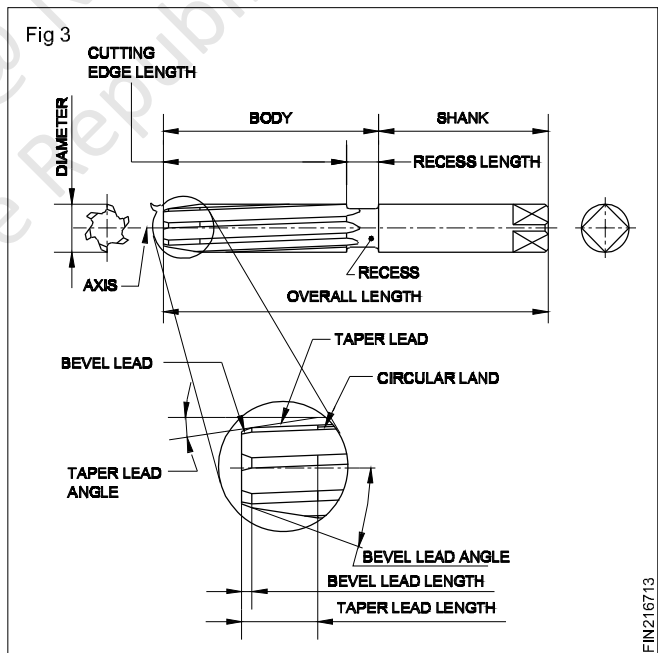

Axis

The longitudinal centre line of the reamer.

Body

The portion of the reamer extending from the entering end of the reamer to the commencement of the shank.

Recess

The portion of the body which is reduced in diameter below the cutting edges, pilot or guide diameters.

Shank

The portion of the reamer which is held and driven. It can be parallel or taper.

Circular land

The cylindrically ground surface adjacent to the cutting edge on the leading edge of the land.

Bevel lead

The bevel lead cutting portion at the entering end of the reamer cutting its way into the hole. It is not provided with a circular land.

Taper lead

The tapered cutting portion at the entering end to facilitate cutting and finishing of the hole. It is not provided with a circular land.

Bevel lead angle

The angle formed by the cutting edges of the bevel lead and the reamer axis.

Taper lead angle

The angle formed by the cutting edges of the taper and the reamer axis.

Terms relating to cutting geometry

Flutes

The grooves in the body of the reamer to provide cutting edges, to permit the removal of chips, and to allow the cutting fluid to reach the cutting edges. (Fig 4)

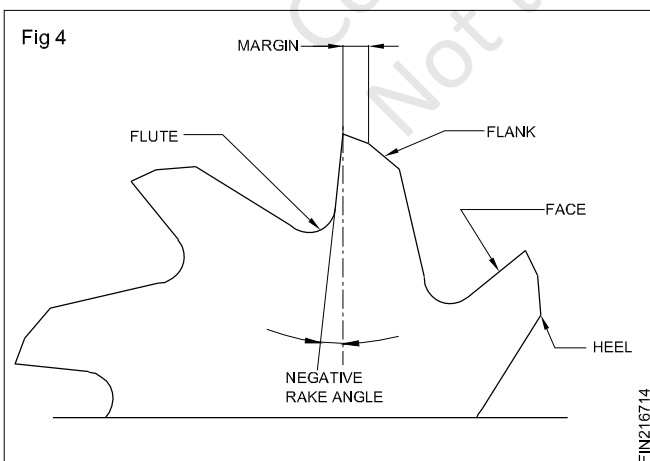

Heel

The edge formed by the intersection of the surface left by the provision of a secondary clearance and the flute. (Fig 4)

Cutting edge

The edge formed by the intersection of the face and the circular land or the surface left by the provision of primary clearance. (Fig 4)

Face

The portion of the flute surface adjacent to the cutting edge on which the chip impinges as it is cut from the work. (Fig 4)

Rake angles

The angles in a diametral plane formed by the face and a radial line from the cutting edge. (Fig 5)

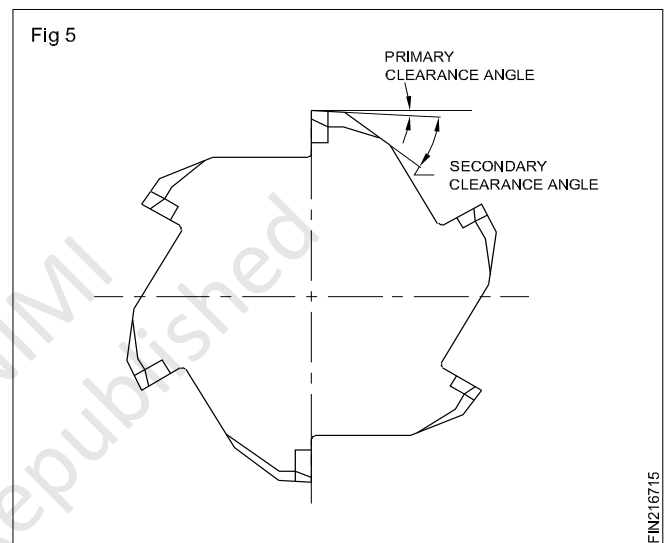

Clearance angle

The angles formed by the primary or secondary clearances and the tangent to the periphery of the reamer at the cutting edge. They are called primary clearance angle and secondary clearance angle respectively. (Fig 6)

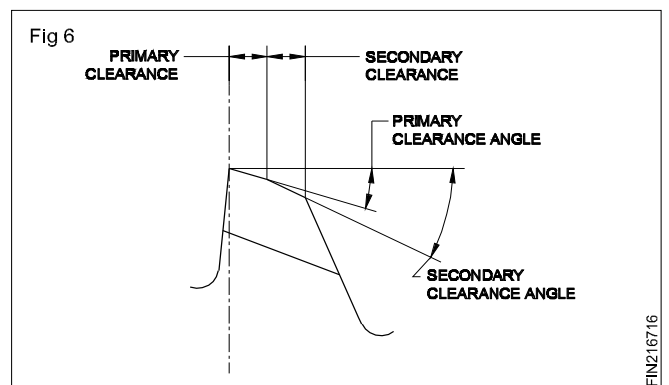

Helix angle

The angle between the edge and the reamer axis. (Fig 7)

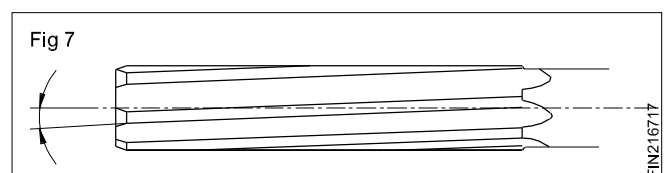

Hand reamers

Objectives: At the end of this lesson you shall be able to

- state the general features of hand reamers
- identify the types of hand reamers
- distinguish between the uses of straight fluted and helical fluted reamers
- name the materials from which reamers are made and specify reamers.

General features of hand reamers (Fig 1)

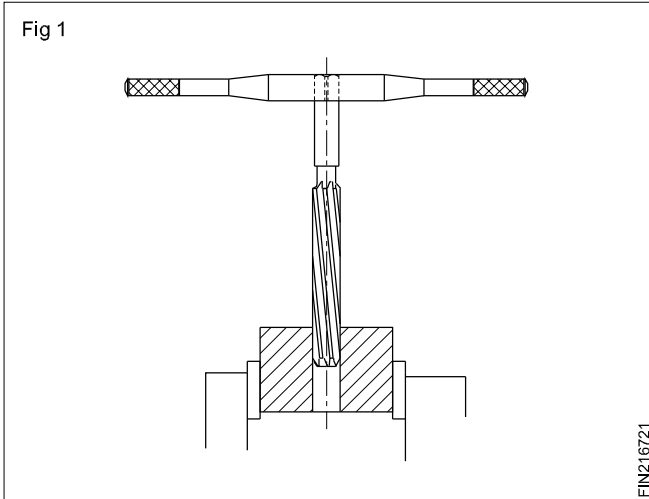

Hand reamers are used to ream holes manually using tap wrenches.

These reamers have a long taper lead. (Fig 2) This allows to start the reamer straight and in alignment with the hole being reamed.

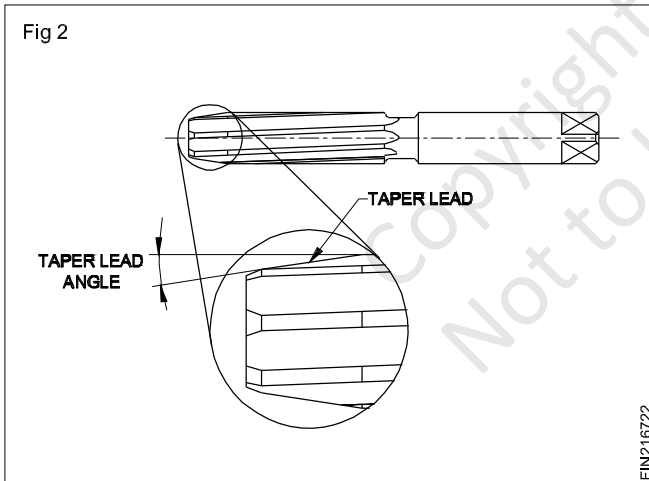

Most hand reamers are for right hand cutting.

Helical fluted hand reamers have left hand helix. The left hand helix will produce smooth cutting action and finish.

Most reamers, machine or hand, have uneven spacing of teeth. This feature of reamers helps to reduce chattering while reaming. (Fig 3)

Types, features and functions

Hand reamers with different features are available for meeting different reaming conditions. The commonly used types are listed here under:

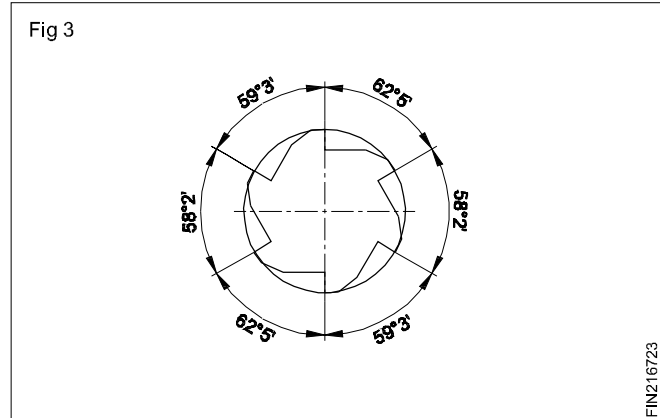

Parallel hand reamer with parallel shank (Fig 4a)

A reamer which has virtually parallel cutting edges with taper and bevel lead. The body of the reamer is integral with a shank. The shank has the nominal diameter of the cutting edges. One end of the shank is square shaped for tuning it with a tap wrench. Parallel reamers are available with straight and helical flutes. This is the commonly used hand reamer for reaming holes with parallel sides.

Reamers commonly used in workshop produce H7 holes.

Hand reamer with pilot (Fig 4b)

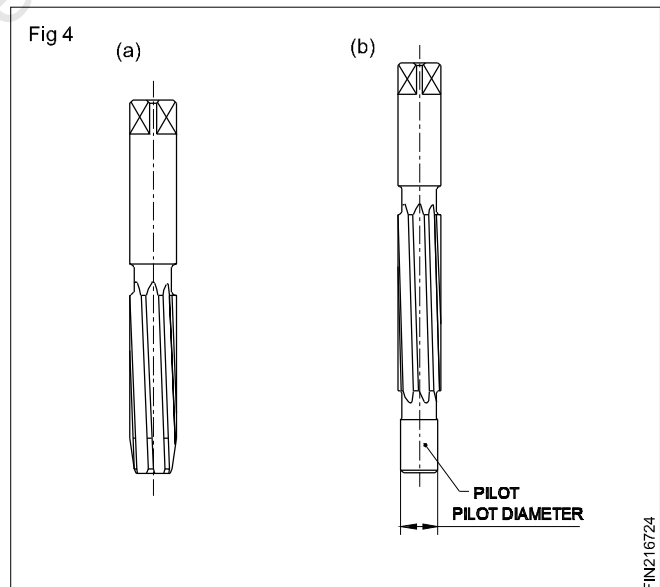

For this type of reamer, a portion of the body is cylindrically ground to form a pilot at the entering end. The pilot keeps the reamer concentric with the hole being reamed.

Socket reamer with parallel shank (Figs 5a and 5b)

This reamer has tapered cutting edges to suit metric morse tapers. The shank is integral with the body, and is square shaped for driving. The flutes are either straight or helical.

The socket reamer is used for reaming internal morse tapered holes.

Taper pin hand reamer (Fig 5c)

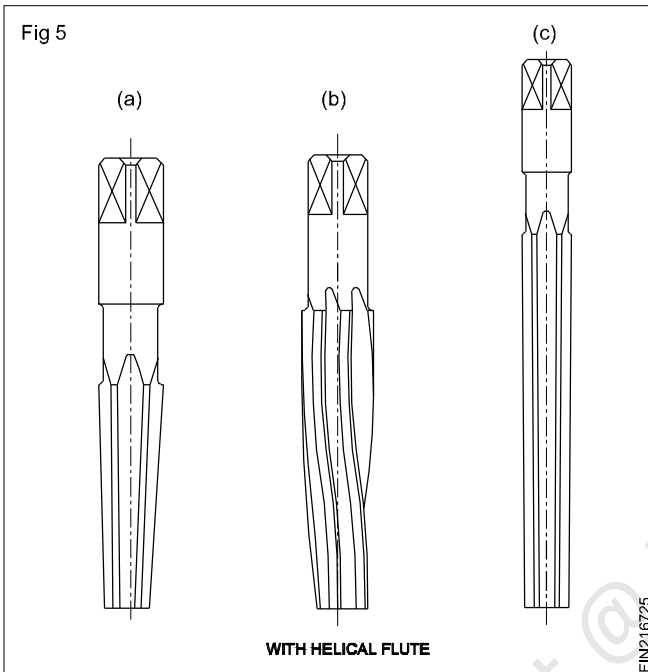

This reamer has tapered cutting edges for reaming taper holes to suit taper pins. A taper pin reamer is made with a taper of 1 in 50. These reamers are available with straight or helical flutes.

Use of straight and helical fluted reamers (Fig 6)

Straight fluted reamers are useful for general reaming work. Helical fluted reamers are particularly suitable for reaming holes with keyway grooves or special lines cut into them. The helical flutes will bridge the gap and reduce binding and chattering.

Drill size for reaming

Objective: At the end of this lesson you shall be able to
• **determine the hole size for reaming.**

For reaming with a hand or a machine reamer, the hole drilled should be smaller than the reamer size.

The drilled hole should have sufficient metal for finishing with the reamer. Excessive metal will impose a strain on the cutting edge of the reamer and damage it.

Calculating drill size for reamer

A method generally practised in workshop is by applying the following formula.

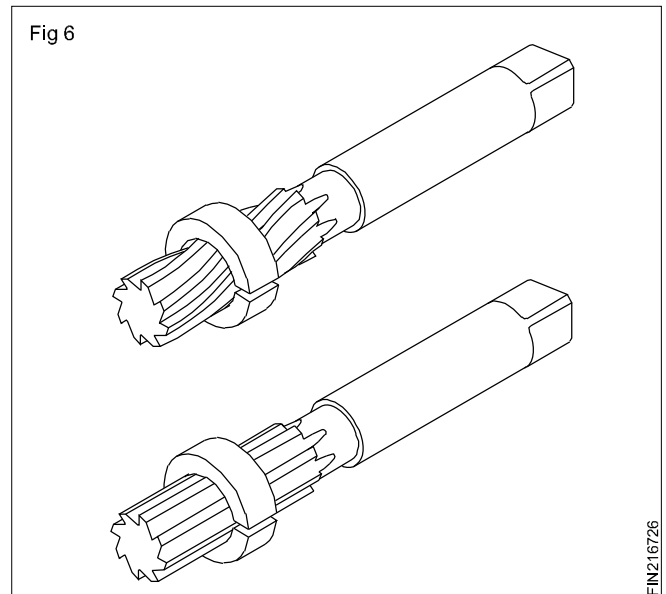

Material of hand reamers

When the reamers are made as a one-piece construction, high speed steel is used. When they are made as two-piece construction then the cutting portion is made of high speed steel while the shank portion is made of carbon steel. They are butt-welded together before manufacturing.

Specifications of a reamer

To specify a reamer the following data is to be given.

Type

Flute

Shank end

Size

Example : Hand reamer, Straight flute, Parallel shank of \varnothing 20 mm.

Drill size = Reamed size – (Undersize + Oversize)

Finished size

Finished size is the diameter of the reamer.

Undersize

Undersize is the recommended reduction in size for different ranges of drill diameter. (Table 1)

Undersizes for reaming

TABLE 1

Diameter of ready reamed hole (mm)	Undersize of rough bored hole (mm)
under 5	0.1.....0.2
5.....20	0.2.....0.3
21....50	0.3.....0.5
over 50	0.5.....1

Oversize

It is generally considered that a twist drill will make a hole larger than its diameter. The oversize for calculation purposes is taken as 0.05 mm - for all diameters of drills.

For light metals the undersize will be chosen 50% larger.

Example

A hole is to be reamed on mild steel with a 10 mm reamer. What will be the diameter of the drill for drilling the hole before reaming?

Drill size = Reamed size – (Undersize + Oversize)

(Finished size) = 10 mm

Undersize as per table = 0.2 mm

Oversize = 0.05 mm

Drill size = 10 mm -- 0.25 mm
= 9.75 mm

Determine the drill hole sizes for the following reamers:

- i 15 mm
- ii 4 mm
- iii 40 mm
- iv 19 mm

Answer

- i _____
- ii _____
- iii _____
- iv _____

Note: If the reamed hole is undersize, the cause is that the reamer is worn out.

Always inspect the condition of the reamer before commencing reaming.

For obtaining good surface finish

Use a coolant while reaming. Remove metal chips from the reamer frequently. Advance the reamer slowly into the work.

Defects in reaming - Causes and Remedies

• Reamed hole undersize

- If a worn out reamer is used, it may result in the reamed hole bearing undersize. Do not use such reamers.
- Always inspect the condition of the reamer before using.

• Surface finish rough

- The causes may be any one of the following or a combinations thereof.
- Incorrect application
- Swarf accumulated in reamer flutes
- Inadequate flow of coolant
- Feed rate too fast
- While reaming apply a steady and slow feed-rate.
- Ensure a continuous supply of the coolant.
- Do not turn the reamer in the reverse direction.

Determining the drill size for reaming

Use the formula,

drill diameter = reamed hole size. (undersize + oversize)

Refer to the table for the recommended undersizes in Related Theory on DRILL SIZES FOR REAMING.

Reaming

Objectives : At the end of this lesson you shall be able to

- state the procedure for hand reaming and machine reaming.

Reaming

Reaming is the operation of finishing and sizing a hole which has been previously drilled, bored, casted holes. The tool used is called a reamer, which has multiple cutting edges. Manually it is held in a tap wrench and reamed. Machine reamer are used in drilling machine using sleeves (or) socket. Normally the speed for reaming will be $\frac{1}{3}^{\text{rd}}$ speed of drilling.

Hand Reaming

Drill holes for reaming as per the sizes determined.

Place the work on parallels while setting on the machine vice. (Fig 1)

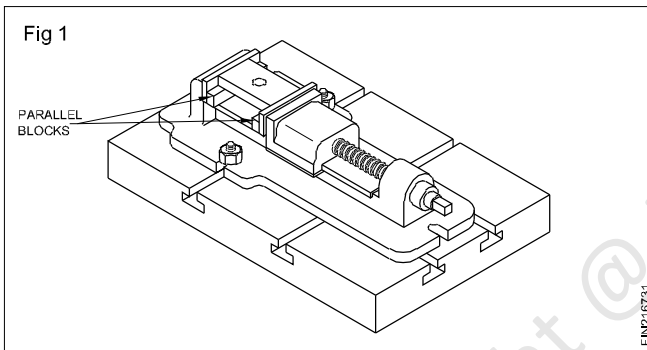

Chamfer the hole ends slightly. This removes burrs and will also help to align the reamer vertically. (Fig 2) Fix the work in the bench vice. Use vice clamps to protect the finished surfaces. Ensure that the job is horizontal. (Fig 2)

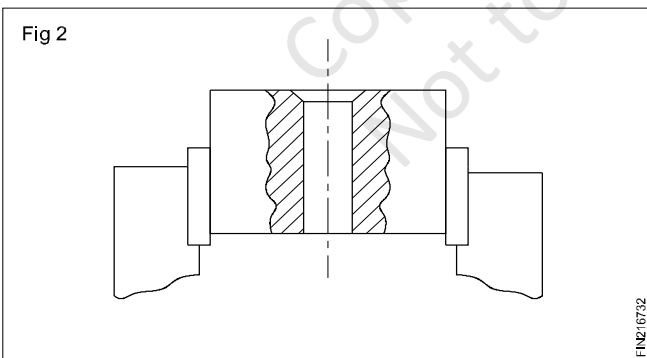

Fix the tap wrench on the square end and place the reamer vertically in the hole. Check the alignment with a try square. Make corrections, if necessary. Turn the tap wrench in a clockwise direction applying a slight downward pressure at the same time. (Fig 3) Apply pressure evenly at both ends of the tap wrench.

Apply cutting force

Turn the tap wrench steadily and slowly, maintaining the downward pressure.

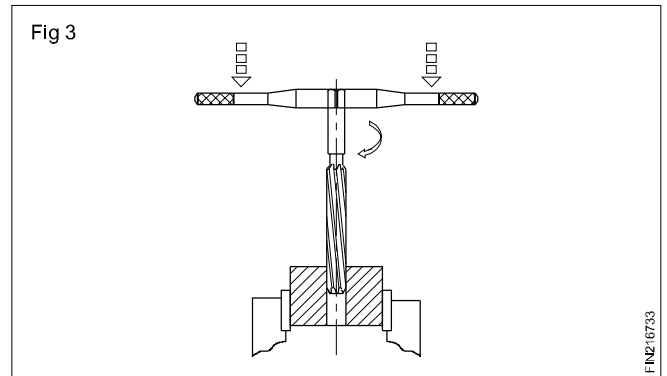

Do not turn in reverse direction it will scratch the reamed hole. (Fig 4)

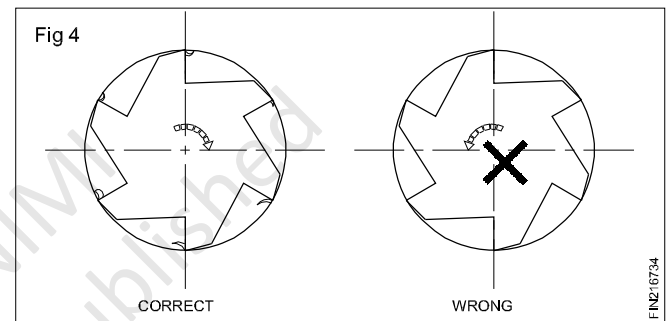

Ream the hole through, ensure that the taper lead length of the reamer comes out well and clear from the bottom of the work. Do not allow the end of the reamer to strike on the vice.

Remove the reamer with an upward pull until the reamer is clear of the hole. (Fig 5)

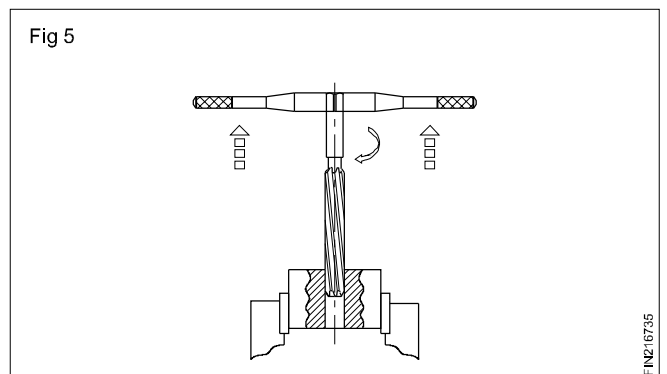

Remove the burrs from the bottom of the reamed hole.

Clean the hole. Check the accuracy with the cylindrical pins supplied.

Screw thread and elements

Objectives: At the end of this lesson you shall be able to

- state the terminology of screw threads
- state the types of screw threads.

Screw thread terminology

Parts of screw thread (Fig 1)

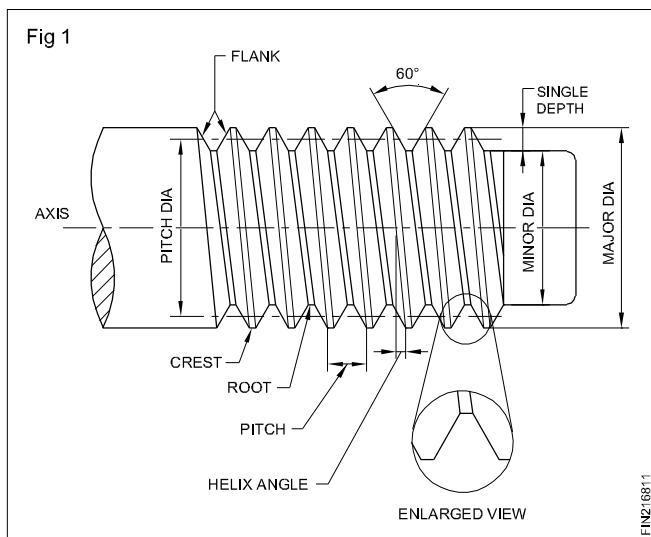

Crest

The top surface joining the two sides of a thread.

Root

The bottom surface joining the two sides of adjacent threads.

Flank

The surface joining the crest and the root.

Thread angle

The included angle between the flanks of adjacent threads.

Depth

The perpendicular distance between the roots and crest of the thread.

Major Diameter

In the case of external threads it is the diameter of the blank on which the threads are cut and in the case of internal threads it is the largest diameter after the threads are cut that are known as the major diameter. (Fig 2)

This is the diameter by which the sizes of screws are stated.

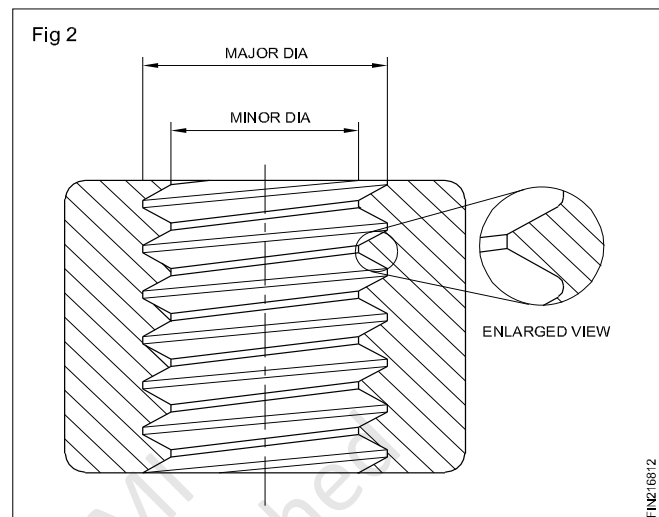

Minor Diameter

For external threads, the minor diameter is the smallest diameter after cutting the full thread. In the case of internal threads, it is the diameter of the hole drilled for forming the thread which is the minor diameter.

Pitch Diameter (effective diameter)

The diameter of the thread at which the thread thickness is equal to one half of the pitch.

Pitch

It is the distance from a point on one thread to a corresponding point on the adjacent thread measured parallel to the axis.

Lead

Lead is the distance of a threaded component moves along the matching component during one complete revolution. For a single start thread the lead is equal to the pitch.

Helix Angle

The angle of inclination of the thread to the imaginary perpendicular line.

Hand

The direction in which the thread is turned to advance. A right hand thread is turned clockwise to advance, while a left hand thread is turned anticlockwise. (Fig 3)

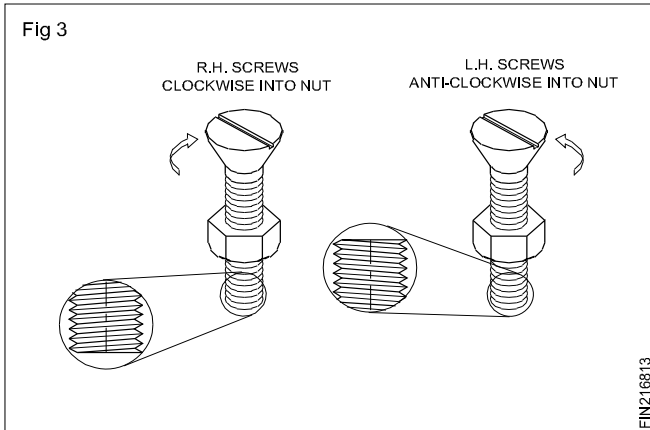

Screw threads - types of V threads and their uses

Objectives: At the end of this lesson you shall be able to

- state the different standards of V threads
- indicate the angle and the relation between the pitch with the other elements of the thread
- state the uses of the different standards of V threads.

The different standards of V threads are:

- BSW thread: British Standard Whitworth thread
- BSF thread: British Standard fine thread
- BSP thread: British Standard pipe thread
- B.A thread: British Association thread
- I.S.O Metric thread: International Standard Organisation metric thread
- ANS: American National or sellers' thread
- BIS Metric thread: Bureau of Indian Standard metric thread.

BSW thread (Fig 1)

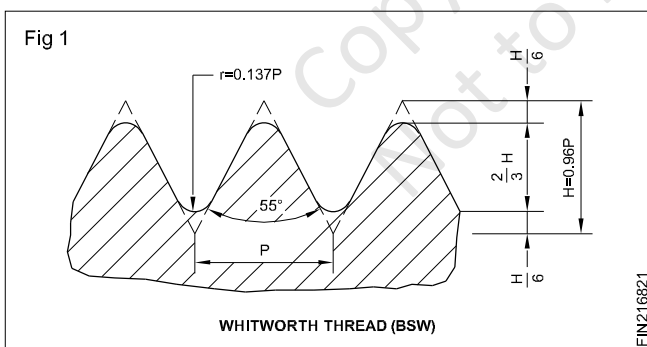

It has an included angle of 55° and the depth of the thread is $0.6403 \times P$. The crest and root are rounded off to a definite radius. The figure shows the relationship between the pitch and the other elements of the thread.

BSW thread is represented in a drawing by giving the major diameter. For example : $1/2''$ BSW, $1/4''$ BSW. The table indicates the standard number of TPI for different diameters. BSW thread is used for general purpose fastening threads.

BSF thread

This thread is similar to BSW thread except the number of TPI for a particular diameter. The number of threads per inch is more than that for the BSW thread for a particular diameter. For Example, $1''$ BSW has 8 TPI and $1''$ BSF has 10 TPI. The table indicates the standard number of TPI for different dia. of BSF threads. It is used in automobile industries.

BSP thread

This thread is recommended for pipe and pipe fittings. The table shows the pitch for different diameters. It is also similar to BSW thread. The thread is cut externally with a small taper for the threaded length. This avoids the leakage in the assembly and provides for further adjustment when slackness is felt.

BA thread (Fig 2)

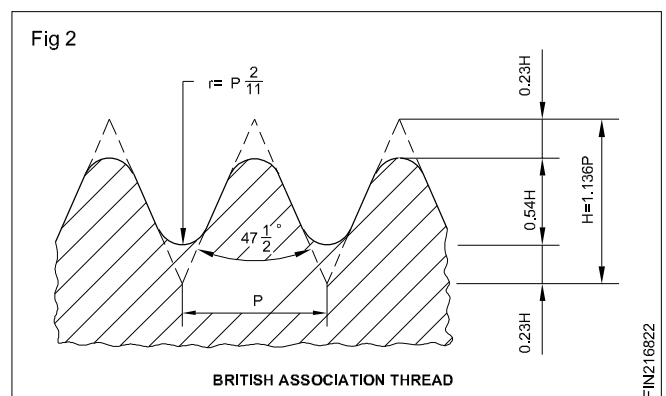

This thread has an included angle of $47 \frac{1}{2}^\circ$. Depth and other elements are as shown in the figure. It is used in small screws of electrical appliances, watch screws, screws of scientific apparatus.

Unified thread (Fig 3)

For both the metric and inch series, ISO has developed this thread. Its angle is 60°. The crest and root are flat and the other dimensions are as shown in the figure. This thread is used for general fastening purposes.

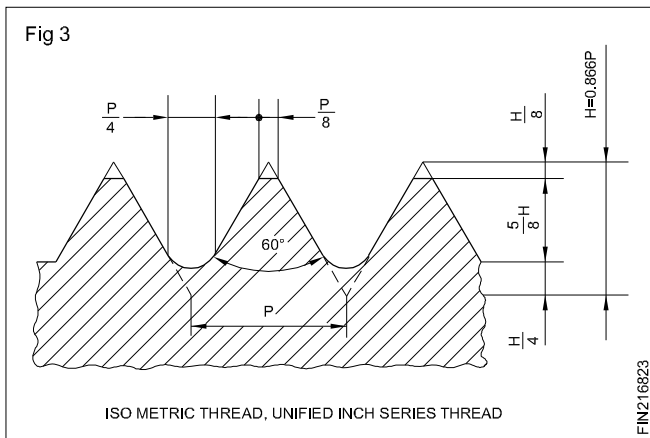

This thread of metric standard is represented in a drawing by the letter 'M' followed by the major diameter for the coarse series.

Ex : M14, M12 etc.

Screw pitch gauge

Objectives: At the end of this lesson you shall be able to

- state the purpose of a screw pitch gauge
- state the features of a screw pitch gauge.

Purpose

A screw pitch gauge is used to determine the pitch of a thread.

It is also used to compare the profile of threads.

Constructional features

Pitch gauges are available with a number of blades assembled as a set. Each blade is meant for checking a particular standard thread pitch. The blades are made of thin spring steel sheets, and are hardened.

Some screw pitch gauge sets will have blades provided for checking British Standard threads (BSW, BSF etc.) at one end and the metric standard at the other end.

Taps

Objectives: At the end of this lesson you shall be able to

- state the uses of hand taps
- state the features of hand taps
- distinguish between the different taps in a set.

Use of hand taps: Hand taps are used for internal threading of components.

For the fine series, the letter 'M' is followed by the major diameter and pitch.

Ex : M14 x 1.5

M24 x 2

American National Thread (Fig 4)

These threads are also called as seller's threads. It was more commonly used prior to the introduction of the ISO unified thread.

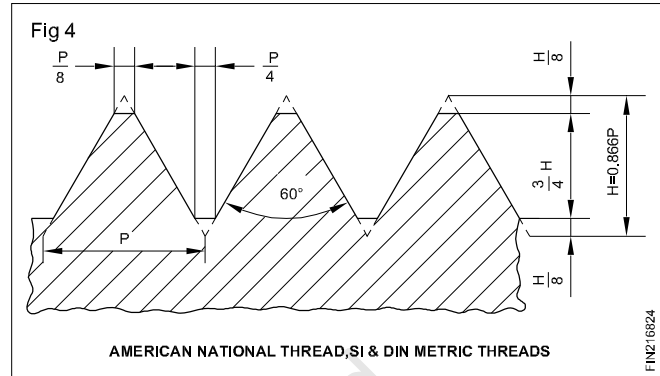

The thread profile on each blade is cut for about 25 mm to 30 mm. The pitch of the blade is stamped on each blade. The standard and range of the pitches are marked on the case. (Fig 1)

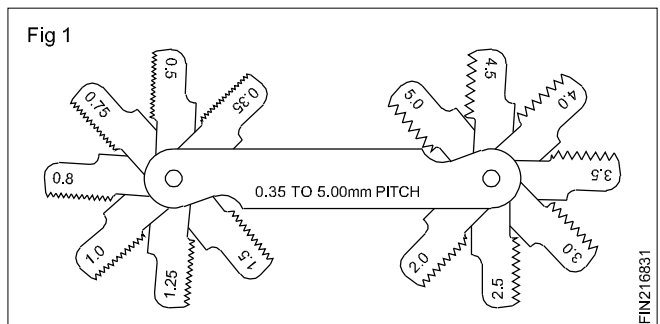

Features (Fig 1): They are made from high speed steel.

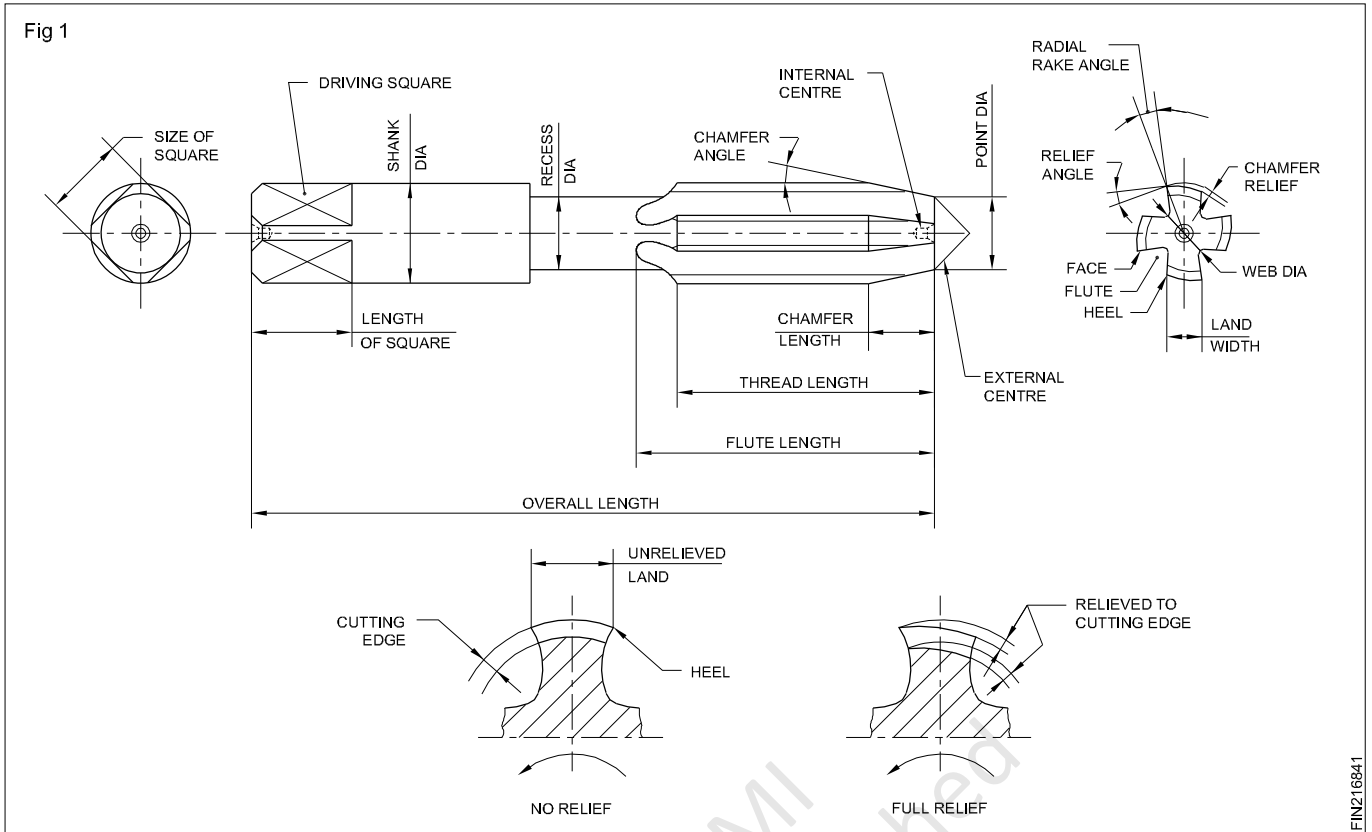

FINZ16841

The threads are cut on the periphery and are accurately finished.

To form the cutting edges, flutes are cut across the thread.

The end of the shank of the tap is made of square shape for the purpose of holding and turning the taps.

The end of the taps are chamfered (taper lead) for assisting, aligning and starting of the thread.

The size of the taps, the thread standard, the pitch of the thread, the dia. of the tapping hole are usually marked on the shank.

Marking on the shank are also made to indicate the type of tap i.e. first, second and plug.

Types of taps in a set : Hand taps for a particular thread are available as a set consisting of three pieces. (Fig 2)

These are:

- First tap or taper tap
- Second tap or intermediate tap
- Plug or bottoming tap.

These taps are identical in all features except in the tap lead.

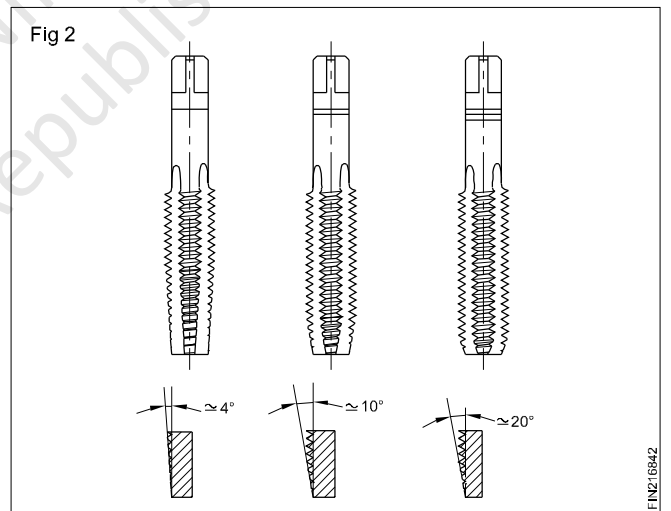

FINZ16842

The taper tap is to start the thread. It is possible to form full threads by the taper tap in through holes which are not deep.

The bottoming tap (plug) is used to finish the threads of a blind hole to the correct depth.

For identifying the type of taps quickly - the taps are either numbered 1,2 and 3 or rings are marked on the shank.

The taper tap has one ring, the intermediate tap has two and the bottoming tap has three rings. (Fig 2)

Table for tap drill size

B.S.W. (55°)		
Tap size (inch)	Threads per inch	Tap drill size (mm)
3/16	24	3.7mm
7/32	24	4.5mm
1/4	20	5.1mm
5/16	18	6.5mm
3/8	16	7.94mm
7/16	14	9.3mm
1/2	12	10.5mm
9/16	12	12.1mm
5/8	11	13.5mm
11/16	11	15mm
3/4	10	16.257mm
7/8	9	19.25mm
1"	8	22mm

B.S.F. (55°)		
Tap size (inch)	Threads per inch	Tap drill size (mm)
3/16	32	3.97mm
7/32	28	4.6mm
1/4	26	5.3mm
5/16	22	6.75mm
3/8	20	8.2mm
7/16	18	9.7mm
1/2	16	11.11mm
9/16	16	12.7mm
5/8	14	14mm
11/16	14	15.5mm
3/4	12	16.75mm
7/8	11	19.84mm
1"	10	22.75mm

NPT National pipe thread

Tap size (inch)	Threads per inch	Tap drill size inch	Tap size (inch)	Threads per inch	Tap drill size inch
1/8	27	11/32	1	11 1/2	1 5/32
1/4	18	7/16	1 1/4	11 1/4	1 1/2
3/8	18	19/32	1 1/2	11 1/2	1 23/32
1/2	14	23/32	2	11 1/2	2 23/16
3/4	14	15/16	2 1/2	8	2 5/8

Tap drill sizes ISO Inch (Unified) thread

NC National coarse			NF National Fine		
Tap size (inch)	Threads per inch	Tap drill size inch	Tap size (inch)	Threads per inch	Tap drill size inch
1/4	20	13/64	1/4	28	7/32
5/16	18	17/64	5/16	24	17/64
3/8	16	5/16	3/8	24	21/64
7/16	14	3/8	7/16	20	25/64
1/2	13	27/64	1/2	20	29/64
9/16	12	31/64	9/16	18	33/64
5/8	11	17/32	5/8	18	37/64
3/4	10	21/32	3/4	16	11/16
7/8	9	49/64	7/8	14	13/16
1"	8	7/8	1"	14	15/16
1 1/8	7	63/64	1 1/8	12	1 3/6
1 1/4	7	17/64	1 1/4	12	1 11/6
1 3/8	6	17/32	1 3/8	12	1 19/64
1 1/2	6	1 11/32	1 1/2	12	1 27/64
1 3/4	5	1 9/16			
2"	4 1/2	1 25/32			

Machine taps

Objectives: At the end of this lesson you shall be able to

- state the characteristics of machine taps
- name the different types of machine taps
- state the features and uses of different types of machine taps.

Machine taps: Machine taps of different types are available. The two important features of machine taps are

- Ability to withstand the torque needed for threading holes
- Provision for eliminating chip jamming.

Types of machine taps

Gun tap (Spiral pointed tap) (Fig 1)

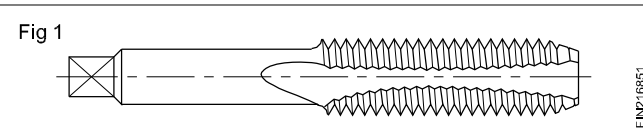

These taps are especially useful for machine tapping of through holes. In the case of blind hole tapping, there should be sufficient space below to accommodate the chips. While tapping, the chips are forced out ahead of the tap. (Fig 2)

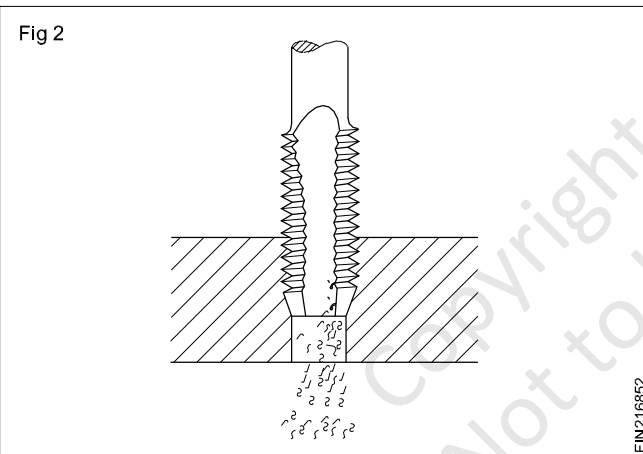

This prevents the clogging of the chips and thus reduces the chances of tap breakage. These taps are stronger since the flutes are shallow. The flutes of these taps do not convey chips.

Flute-less spiral pointed tap (Stub flute taps) (Fig 3):

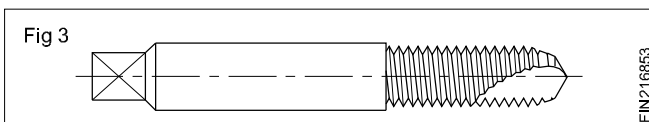

These taps have short angular flutes ground on the chamfered end, and the rest of the body is left solid. These taps are stronger than gun taps.

Flute-less taps are used for tapping through holes on materials which are not thicker than the diameter of the holes. Fluteless spiral point taps are best suited for tapping soft materials or thin metal sections.

Helical fluted taps/spiral fluted taps: These taps have spiral flutes which bring out the chips from the hole being tapped. (Fig 4)

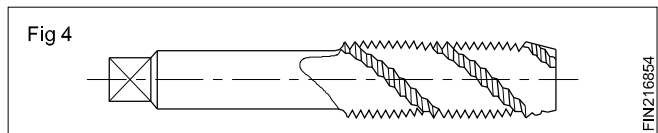

These are useful for tapping holes with slots. The helical land of the tap will bridge the interruption of the surface being threaded. The helical flutes of the tap provide a shear cutting action, and are mostly used to tap holes in ductile materials like aluminium, brass, copper etc.

Spiral fluted taps are also available with fast spiral. (Fig 5) These taps are best suited for tapping deep holes as these can clear the chips faster from the hole. (Fig 6)

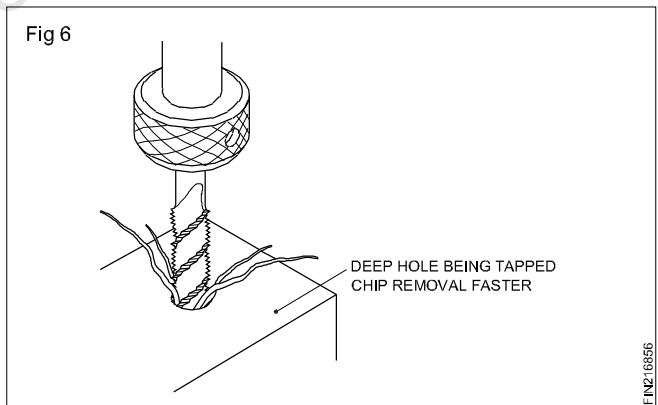
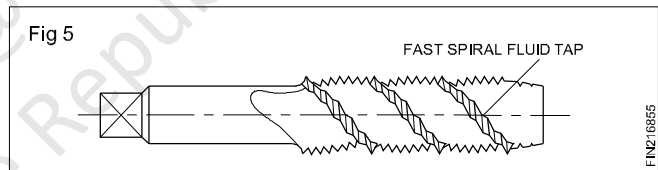

Thread forming taps (Fluteless taps)

These taps form threads in the hole by displacing the material and not by cutting action. (Fig 7)

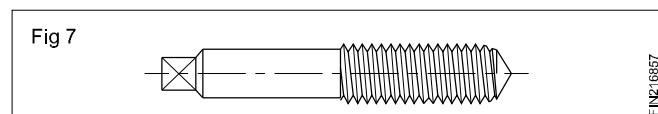

Pipe Threads and Pipe Taps

Objectives: At the end of this lesson you shall be able to

- state parallel and taper pipes threads
- determine the wall thickness and threads per inch (TPI) of BSP threads
- state the method of sealing pipe joints
- determine blank sizes for threading as per B.S 21 - 1973 and I.S. 2643 - 1964.

Pipe threads

The standard pipe fittings are threaded to British Standard pipe (BSP). The internal pipe threads have parallel threads whereas the external pipes have tapered threads as shown in Fig 1.

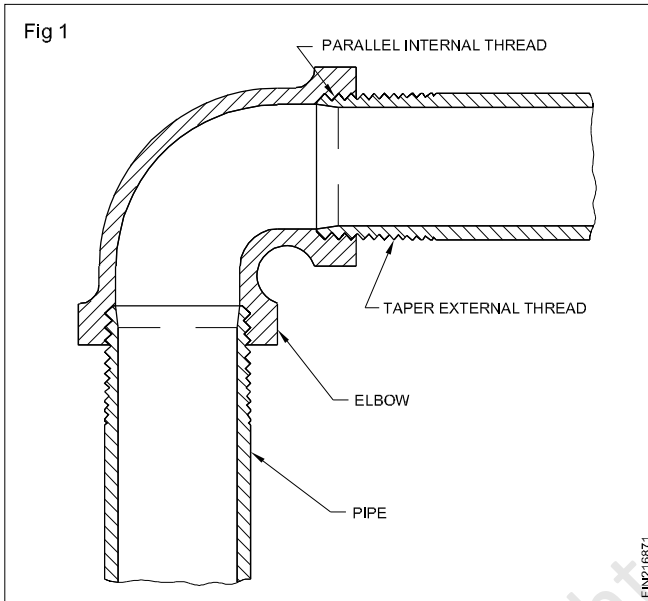

B.S.P. threads

Galvanized iron pipes are available in sizes ranging from 1/2" to 6" in several different wall thickness. The table shows outside diameters and threads per inch from 1/2" to 4". (Fig 2)

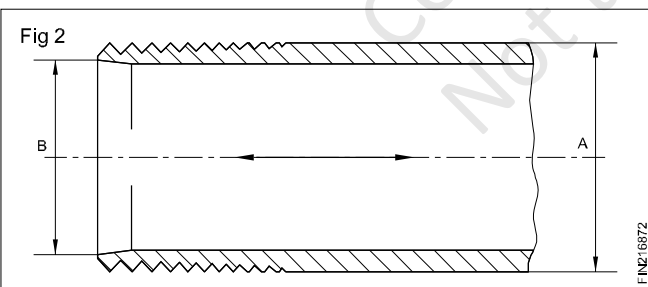

The next two threads have fully formed bottoms but flat tops. (B)

The last four threads have flat tops and bottoms. (C)

Sealing pipe joint

Fig 3 shows that the pipe has several fully formed threads at the end. (A)

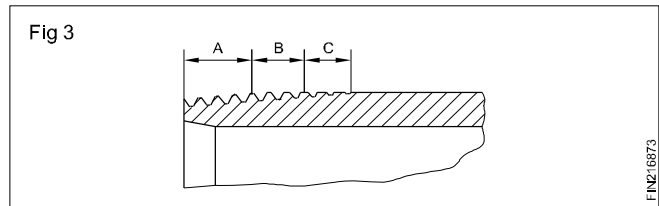

The pipe joint shown in Fig 4 consists of the following:

- 1 Parallel female thread
- 2 Tapered male thread
- 3 Hemp packing

The hemp packing is used to ensure that any small space between two metal threads (male and female threads) is sealed to prevent any leakage.

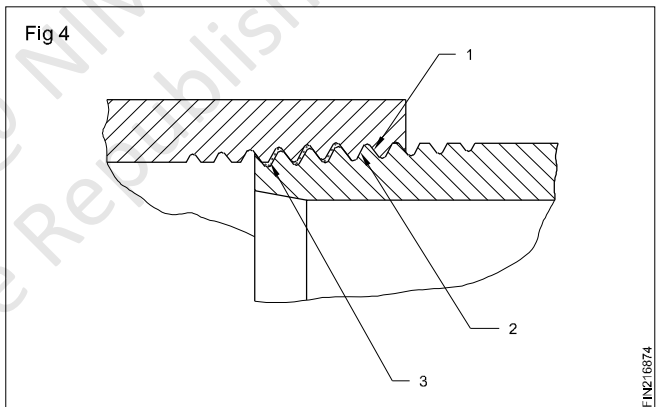

Table

BSP - Pipe sizes or DIN 2999 (inside) (B)	Threads inch	Outside diameter/ mm of the pipe (A)
1/2"	14	20.955 mm
3/4"	14	26.441
1"	11	33.249
1 1/4"	11	41.910
1 1/2"	11	47.803
2"	11	59.614
2 1/2"	8	75.184
3"	8	87.884
4"	8	113.030

Pipe taps

Internal pipe threads are usually cut with standard taper pipe taps. (Fig 5)

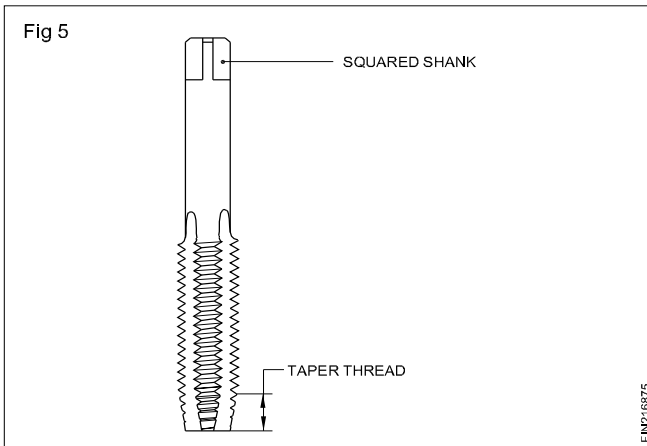

In gauging internal pipe threads, the pipe plug thread gauge should be screwed tight by hand into the pipe until the notch on the gauge is flush with the face. When the thread is chamfered the notch should be flushed with the bottom of the chamfer. (Fig 6)

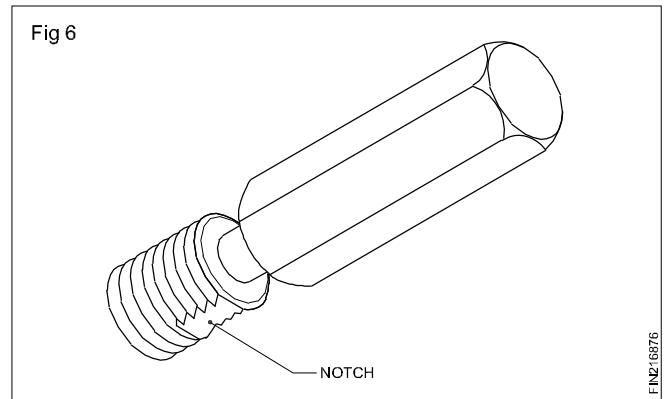

Copyright @ NIMI
Not to be Republished

Tap wrenches, removal of broken tap, studs

Objectives : At the end of this lesson you shall be able to

- name the different types of tap wrenches
- state the uses of the different types of wrenches.

Tap wrenches

Tap wrenches are used to align and drive the hand taps correctly into the hole to be threaded.

Tap wrenches are of different types, such as double-ended adjustable wrench, T- handle tap wrench, solid type tap wrench etc.

Double - ended adjustable tap wrench or bar type tap wrench (Fig 1)

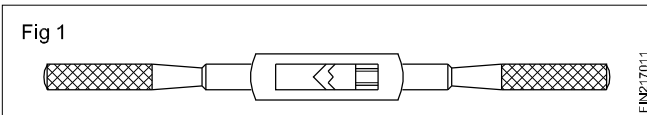

This is the most commonly used type of tap wrench. It is available in various sizes- 175, 250, 350mm long. These tap wrenches are more suitable for large diameter taps, and can be used in open places where there is no obstruction to turn the tap.

It is important to select the correct size of wrench.

T- handle tap wrench (Fig 2)

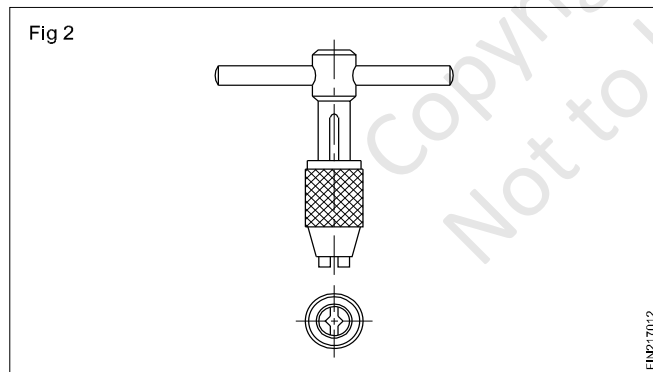

These are small, adjustable chucks with two jaws and a handle to turn the wrench.

This tap wrench is useful to work in restricted places, and is turned with one hand only. Most suitable for smaller sizes of taps.

Solid type tap wrench (Fig 3)

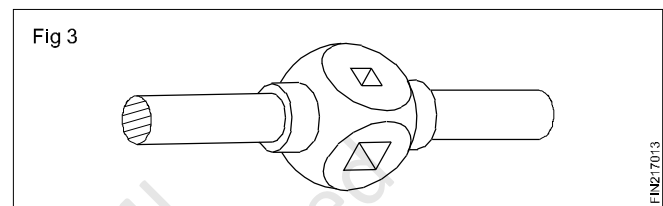

These wrenches are not adjustable.

They can take only certain sizes of taps. This eliminates the use of wrong length of the tap wrenches, and thus prevents damage to the taps.

Material

Made from a single piece of solid Cast iron (or) steel. Cast iron and steel are used because of strong, durable and unlikely to deform under pressure.

Removing broken taps

Objectives: At the end of this lesson you shall be able to

- name the different methods of removing broken taps
- state the methods of removing broken taps.

A tap broken above the surface of the workpiece can be removed using gripping tools like pliers.

Taps broken below the surface pose a problem for removing. Any one of the several methods given below can be used.

Use of tap extractor (Fig 1)

This is a very delicate tool and need very careful handling.

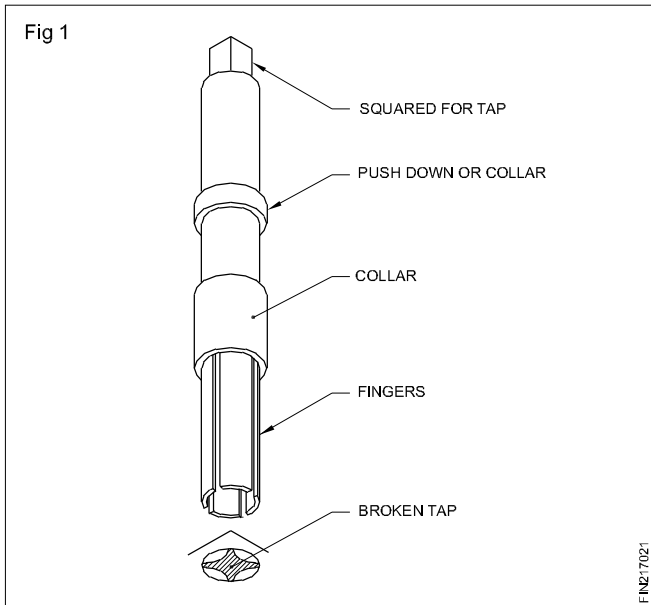

This extractor has fingers which can be inserted on the flutes of the broken tap. The sliding collar is then brought to the surface of the work and the extractor turned anticlockwise to take out the broken tap.

A light blow on the broken tap with a punch will help to relieve the tap if it is jammed inside the hole.

Use of punch (Fig 2)

In this method the point of the punch is placed in the flute of the broken tap in an inclination and struck with a hammer the positioning of the punch should be such that the broken tap is rotated anticlockwise when struck.

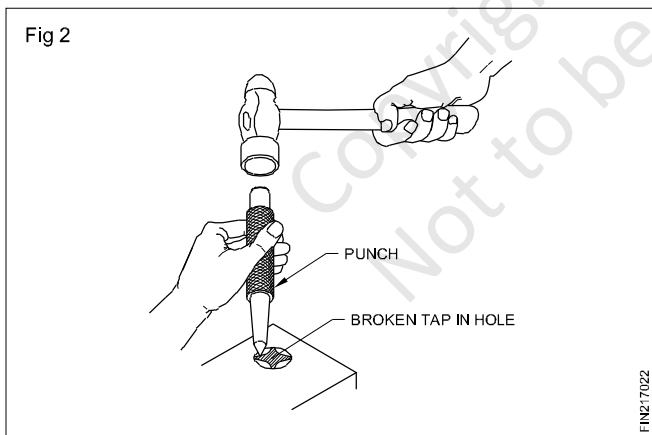

Annealing and drilling the tap

This is a method adopted when other method fail. In the process the broken tap is heated by flame or by other methods for annealing. A hole is then drilled on the annealed tap. The remaining piece can be removed either by using a drift or using an EZY - OUT (extractor). This method is not suitable for workpieces with low melting temperatures such as aluminium, copper etc. (Fig 3)

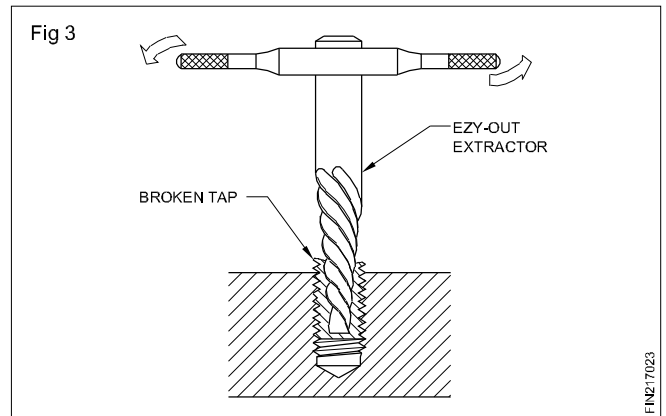

Use of arc welding

This is a suitable method when a small tap is broken at the bottom of materials like copper, aluminium etc. In this method the electrode is brought in contact with the broken tap and stuck so that it is attached with the broken tap. The tap may be removed by rotating the electrode.

Use of nitric acid

In this method nitric acid is diluted in a proportion of about one part acid to five parts of water is injected inside. The action of the acid loosens the tap and then it is removed with an extractor or with a nose plier. The workpiece should be thoroughly cleaned for preventing further action of the acid.

While diluting acid mix acid to water.

Use of spark erosion

For salvaging certain precision components damaged due to breakage of taps, spark erosion can be used. In this process, the metal (broken tap) is removed by means of repetitive spark discharges. The electrical discharge occurs between an electrode and the electro-conductive workpiece (tap) and the minute particles are eroded both from the electrode and the workpiece. In many cases it may not be necessary to remove the broken tap completely. (After a small portion has been eroded, a screw-driver or punch can be used to remove the remaining portion of the tap.) The shape of the electrode also need not be round. It can be for assisting the tools for rotating the broken tap.

Removing broken stud

Objectives: At the end of this lesson you shall be able to

- state the reasons for breakage of stud
- state different methods for removing broken stud.

The stud is used in place of a bolt, when there is insufficient space to accommodate the bolt head or to avoid use of an unnecessarily long bolt. Studs are generally used to fix up cover plates or to connect cylinder covers to engine cylinders.

Reasons for breakage of stud/bolt.

Excessive torque is applied while screwing the stud into the hole.

Corrosive attack on the thread.

Matching threads are not of proper formation.

Threads are seized.

Methods of removing broken studs

Prick punch method

If the stud is broken very near to the surface, drive it in an anticlockwise direction, using a prick punch and hammer to remove it. (Fig 1)

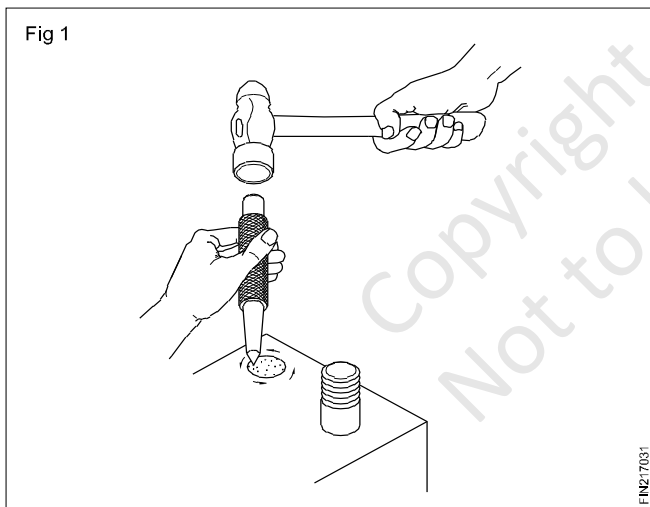

Filing square form

When the stud is broken a little above the surface form a square on the projecting portion to suit a standard spanner. Then turn it anticlockwise using a spanner to remove it. (Fig 2)

Using square taper punch

Broken stud can also be removed by drilling a blind hole (hole diameter equals to half of stud diameter) and driving a square taper punch into the hole as shown in Fig 3. Turn the punch using a suitable spanner in an anti-clockwise direction to unscrew the stud.

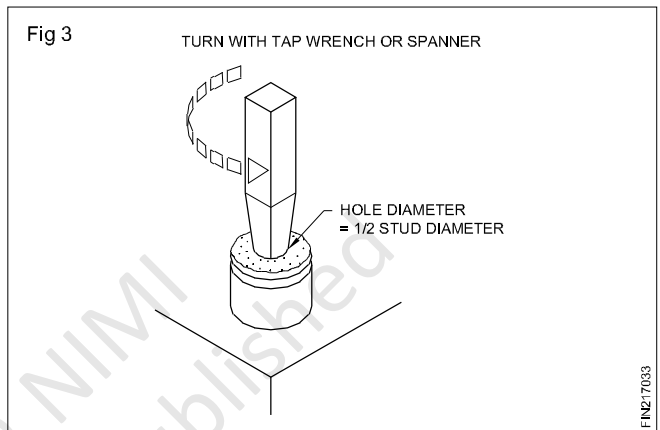
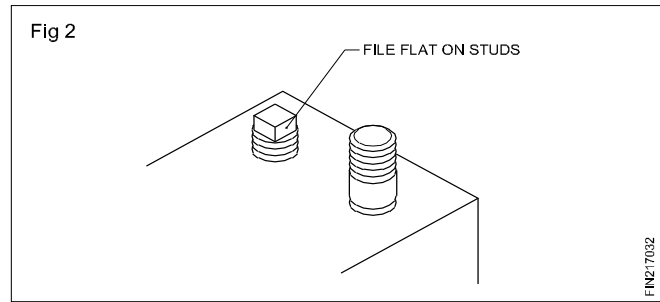

EZY - out method (Fig 4)

Ezy - out or a stud extractor is a hand tool, somewhat similar to the form of a taper reamer but has left hand spiral. It is available in a set of 5 pieces. The recommended drill size is punched on each ezy - out .

After drilling the hole recommended ezy - out is set on it and turned in an anti-clockwise direction by a tap wrench. As it is rotated it penetrates into the hole increasing its grip and in the process the broken stud gets unscrewed. (Fig 4)

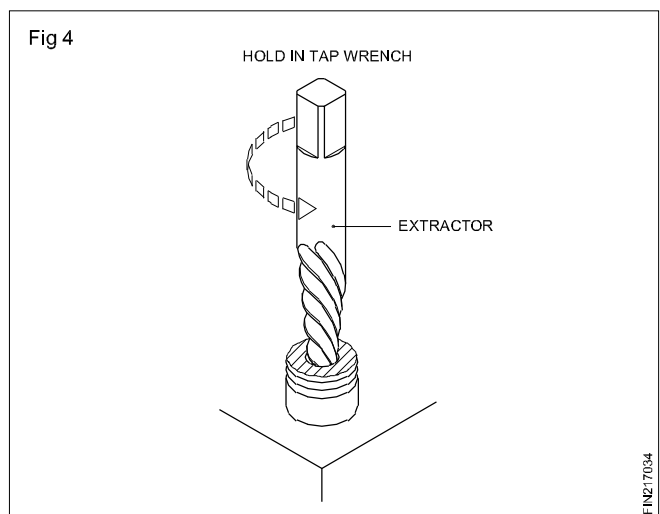

Making drill hole

Correctly find out the centre of the broken stud and drill hole nearly equal to the core diameter of the stud down the centre so that the threads only remain. Remove the thread portion by the point of a scriber in the form of broken chips. Re - tap the drill the hole to clear the threads. (Fig 5)

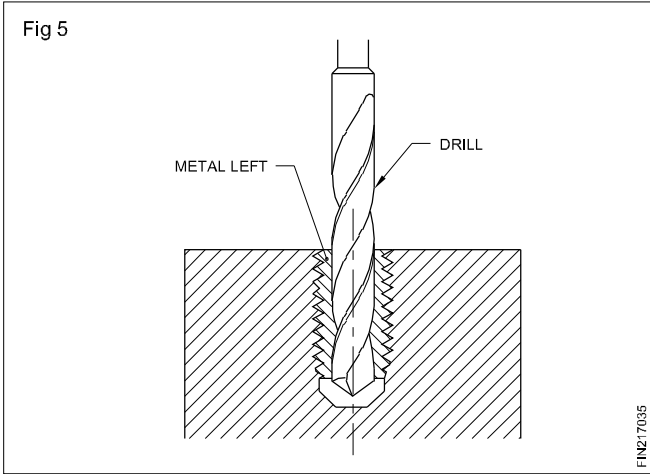

If all other method fail, drill a hole equal to the size of the stud size or a little over and tap the hole with an oversize tap. Now a special over size stud as shown in Fig 6 is to be made and fitted in position.

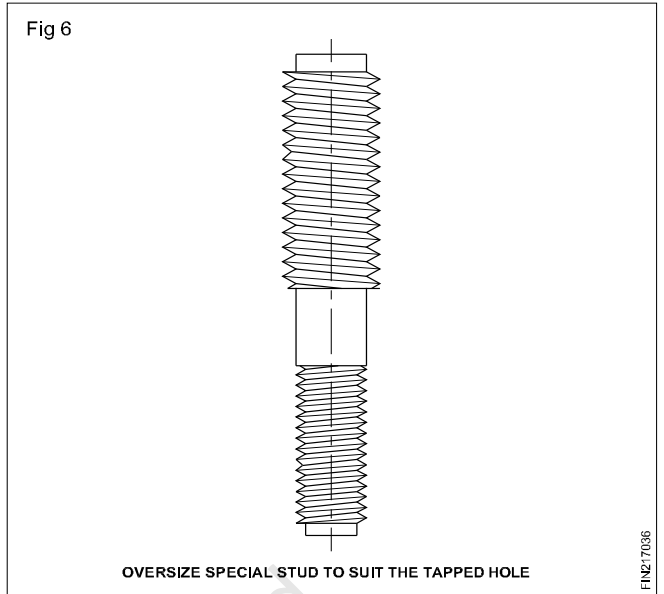

Dies and die stock

Objectives: At the end of this lesson you shall be able to

- identify the different types of dies
- state the features of each type of die
- state the use of each type of die
- name the type of diestock for each type of die.

Uses of dies

Threading dies are used to cut external threads on cylindrical workpieces. (Fig 1)

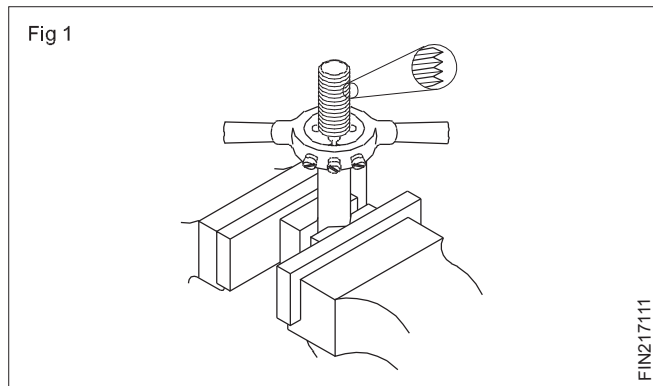

Types of dies

The following are the different types of dies.

Circular split die (Button die)

Half die

Adjustable screw plate die

Circular split die/button die (Fig 2)

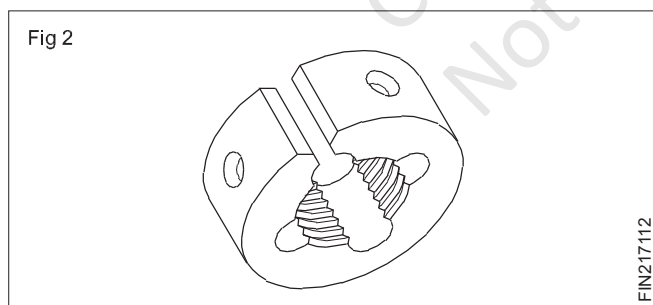

This has a slot cut to permit slight variation in size.

Dies are made of high speed steel

When held in the diestock, variation in the size can be made by using the adjusting screws. This permits increasing or decreasing of the depth of cut. When the side screws are tightened the die will close slightly. (Fig 3) For adjusting the depth of the cut, the centre screw is advanced and locked in the groove. This type of die stock is called button pattern stock

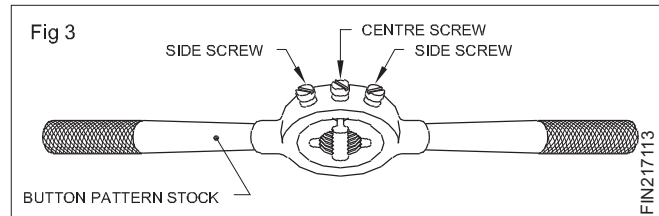

Half die (Fig 4)

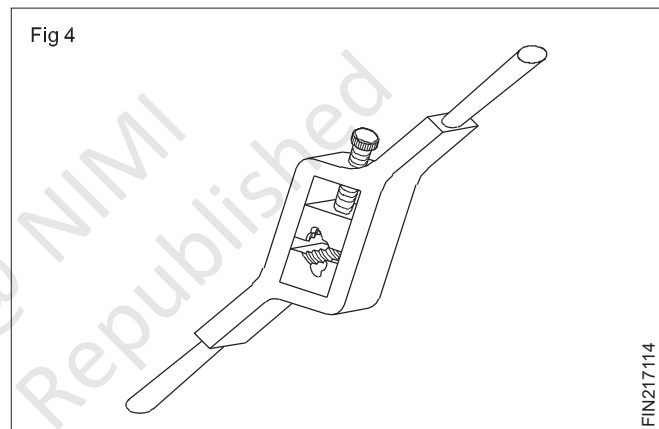

Half dies are stronger in construction.

Adjustments can be made easily to increase or decrease the depth of cut.

These dies are available in matching pairs and should be used together.

By adjusting the screw of the diestock, the die pieces can be brought closer together or can be moved apart.

They need a special die holder.

Adjustable screw plate die (Fig 5)

This is another type of a two piece die similar to the half die.

This provides greater adjustment than the split die.

The two die halves are held securely in a collar by means of a threaded plate (guide plate) which also acts as a guide while threading.

When the guide plate is tightened after placing the die pieces in the collar, the die pieces are correctly located and rigidly held.

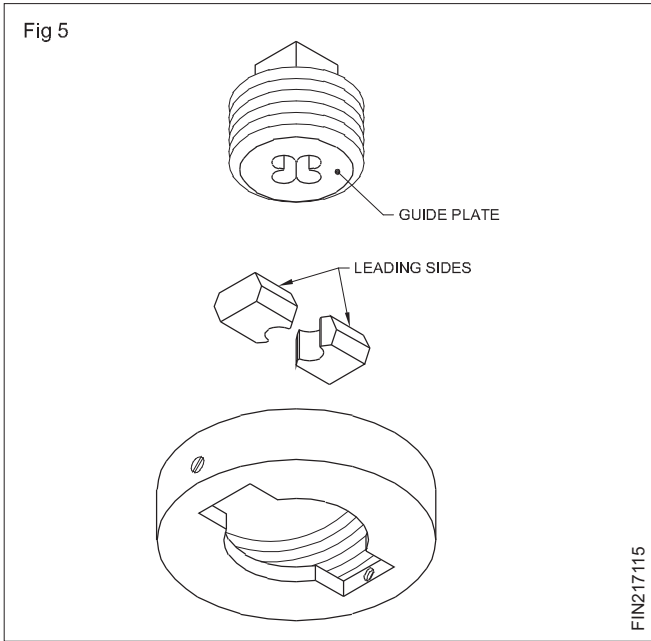

The die pieces can be adjusted, using the adjusting screws on the collar. This type of die stock used is called quick cut diestock. (Fig 6)

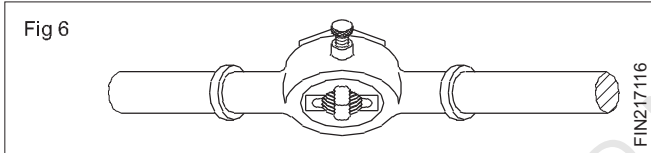

The bottom of the die halves is tapered to provide the lead for starting the thread. On one side of each die head, the serial number is stamped.

Both pieces should have the same serial numbers.

Die Nut (Solid Die) (Fig 7)

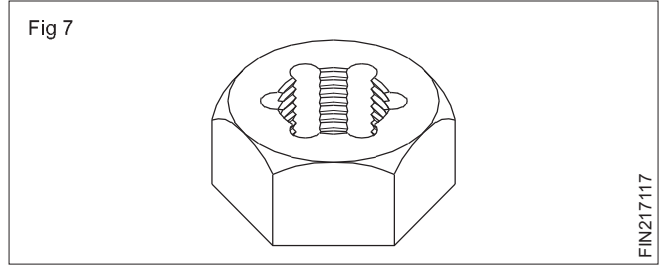

The die nut is used for chasing or reconditioning the damaged threads.

Die nuts are not to be used for cutting new threads.

The die nuts are available for different standards and sizes of threads.

The die nut is turned with a spanner.

Blank size for external threading

Objective: At the end of this lesson you shall be able to
 • **determine the diameter of blank size for external thread cutting.**

Why should the blank size be less?

It has been observed from practice that the threaded diameters of steel blanks show a slight increase in diameter. such increase in the diameter will make assembly of external and internal threaded components very difficult. To overcome this, the diameter of the blank is slightly reduced before commencing the threading.

What should be the blank size?

The diameter of the blank should be less by 1/10th of the pitch of the thread.

Example

For cutting the thread of M12 with 1.75mm pitch the diameter of the blank is 11.80.

Formula, $D = d - p/10$
 $= 12\text{mm} - 0.175\text{mm}$
 $= 11.825$ or 11.8 mm.
 $d =$ diameter of bolt
 $D =$ the blank diameter
 $p =$ pitch of thread

Calculate the blank size for preparing a bolt of M16 x1.5?

Answer

External threading using dies

Objective: At the end of this lesson you shall be able to
 • cut external threads using dies.

Check blank size.

Blank size = Threads size - 0.1 × pitch of thread

Procedure

Fix the die in the diestock and place the leading side of the die opposite to the step of the diestock. (Figs 1a & 1b)

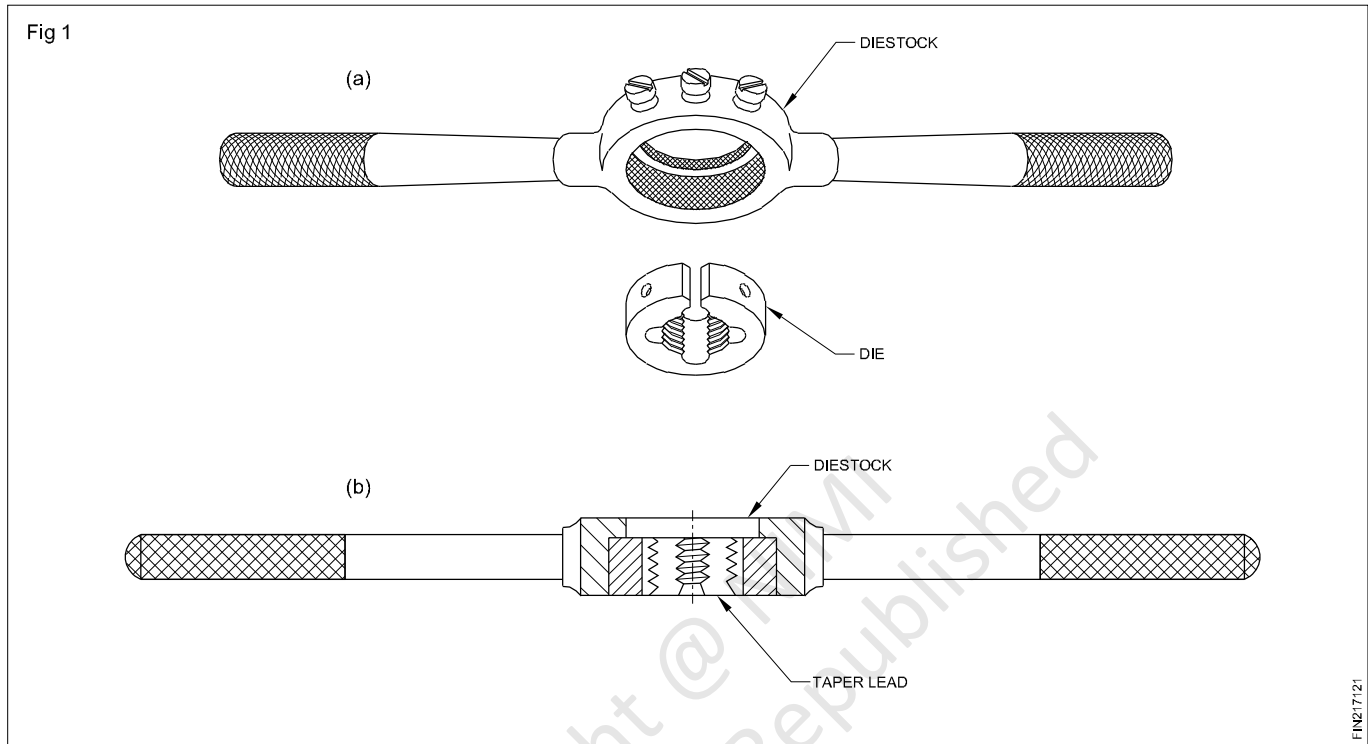

Use false jaws for ensuring a good grip in the vice.
Project the blank above the vice - just the required thread length only.

Place the leading side of the die on the chamfer of the work (Fig 2)

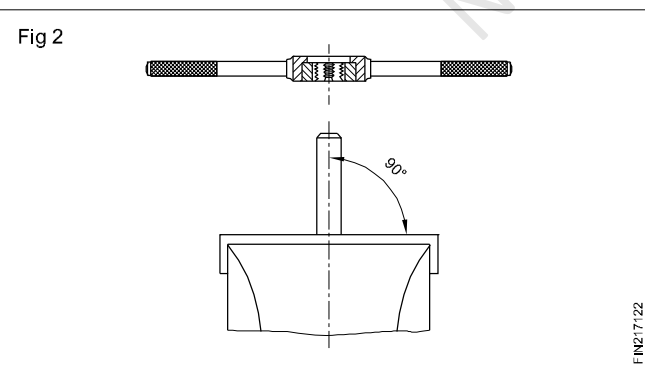

Make sure that the die is fully open by tightening the centre screw of the diestock. (Fig 3)

Start the die, square to the bolt centre line. (Fig 4)

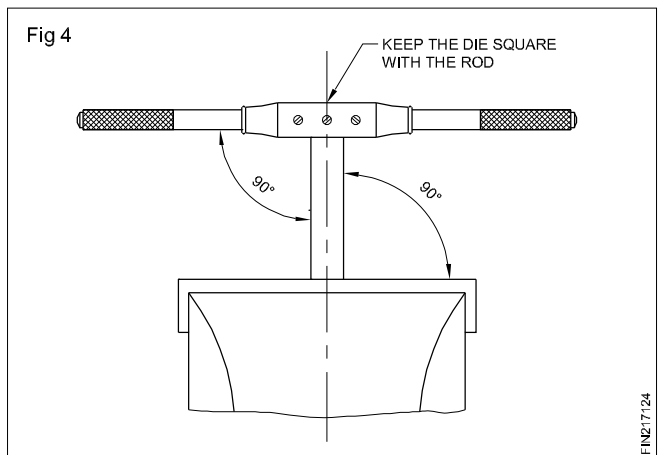
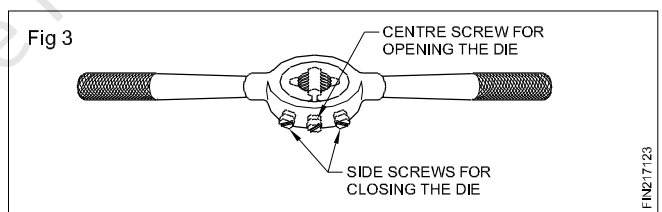

Apply pressure on the diestock evenly and turn clockwise direction to advance the die on the bolt blank. (Fig 5)

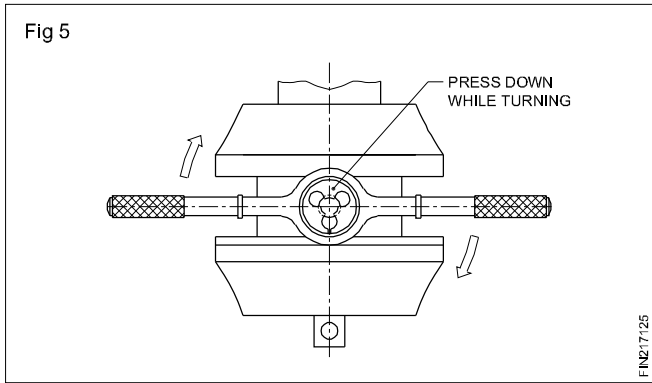

Cut slowly and reverse the die for a short distance in order to break the chips

Use a cutting lubricant.

Increase the depth of the cut gradually by adjusting the outer screws.

Check the thread with a matching nut.

Repeat the cutting until the nut matches.

Too much depth of cut at one time will spoil the threads. It can also spoil the die.

Clean the die frequently to prevent the chips from clogging and spoiling the thread.

Copyright @ NIMI
Not to be Republished

Drill troubles - Causes and remedy, drill kinds

Objectives: At the end of this lesson you shall be able to

- state the common drilling defects
- identify the causes of drilling defects
- suggest remedial steps for preventing drill failures.

The common defects in drilling are listed below.

- Oversized holes
- Overheated drills
- Rough holes
- Unequal and interrupted flow of chips
- Split webs or broken drills

Oversized holes

Oversized holes can be due to:

- The unequal length of the cutting edges (Fig 1)

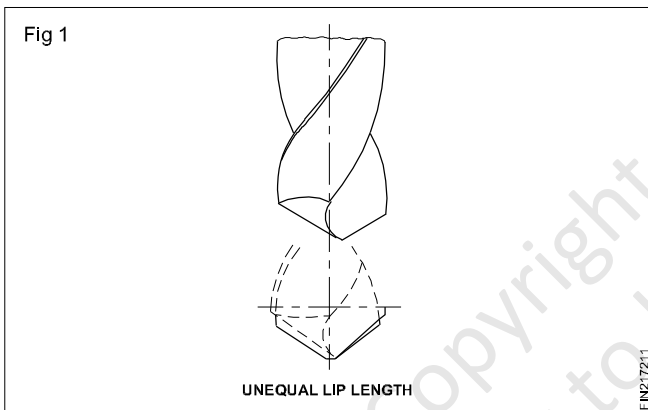

- The unequal angle of the cutting edges (Fig 2)

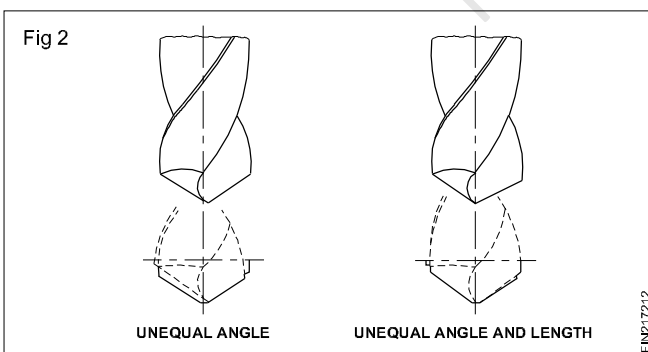

- The unequal thinning of the point (Fig 3)
- The spindle running out of centre
- The drill point not being in centre. (Fig 4)

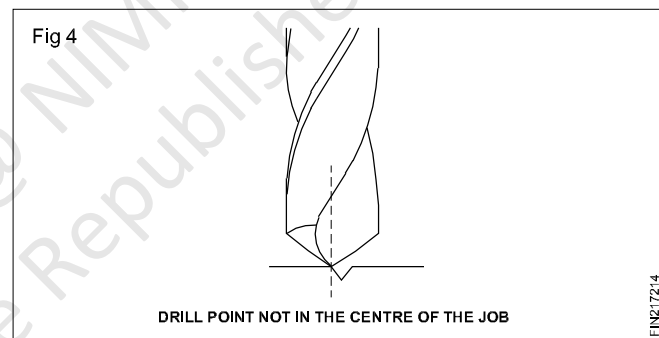
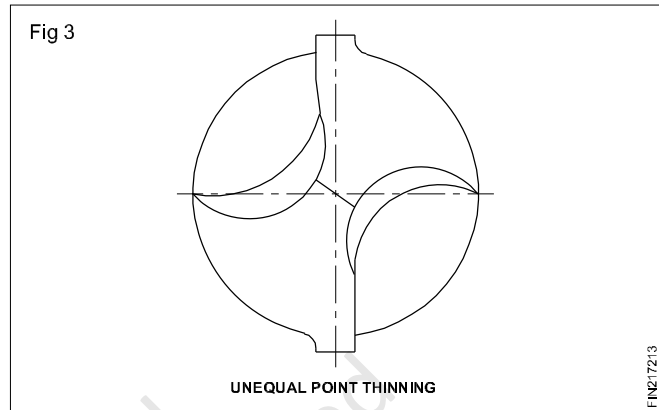

Overheated drills

The drills may get overheated if the:

- Cutting speed is too high
- Feed rate is too high
- Clearance angle is incorrect
- Cooling is ineffective
- Point angle is incorrect
- Drill is not sharp.

Rough holes

Rough holes are caused if the:

- Feed rate is too much
- Drill cutting edges are not sharp
- Cooling is ineffective.

Unequal flow of chips (Fig 5)

Unequal flow of chips is caused if the cutting edges are not equal and the point angle is not in the centre of the drill.

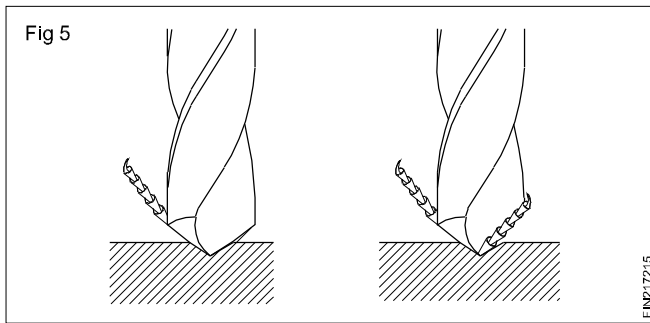

Broken drill or split web

Broken drill or split web occurs when the:

- Cutting speed is too high
- Feed rate is too high
- Work is not held rigidly
- Drill is not held correctly
- Drill is not sharp
- Point angle is incorrect
- Cooling is insufficient
- Flutes are clogged with chips.

Letter and number drills

Objectives: At the end of this lesson you shall be able to

- state the range of drill sizes in number and letter drill series
- determine the number and letter drills for given diameters referring to the chart.

Generally drills are manufactured to standard sizes in the metric system. These drills, are available in specified steps. The drills, which are not covered under the above category, are manufactured in number and letter drills.

These drills are used where odd sizes of holes are to be drilled.

Letter drills:

The letter drill series consists of drill sizes from 'A' to 'Z'. The letter 'A' drill is the smallest with 5.944 mm diameter, and the letter 'Z' is the largest, with a 10.490 mm diameter. (Table 1)

TABLE 1
Letter drill sizes

Letter	Diameter	
	Inches	mm
A	.234	5.944
B	.238	6.045
C	.242	6.147
D	.246	6.248
E	.250	6.35
F	.257	6.528
G	.261	6.629
H	.266	6.756
I	.272	6.909
J	.277	7.036
K	.281	7.137
L	.290	7.366

Letter	Diameter	
	Inches	mm
H	.266	6.756
I	.272	6.909
J	.277	7.036
K	.281	7.137
L	.290	7.366
M	.295	7.493
N	.302	7.671
O	.316	8.026
P	.323	8.204
Q	.332	8.433
R	.339	8.611
S	.348	8.839
T	.358	9.093
U	.368	9.347
V	.377	9.576
W	.386	9.804
X	.397	10.084
Y	.404	10.262
Z	.413	10.490

In the number drill and the letter drill series, the correct diameter of the drill is gauged with the help of the respective drill gauges. A drill gauge is a rectangular or square shaped metal piece containing a number of different diameter holes. The size of the hole is stamped against each hole. (Fig 1)

Fig 1

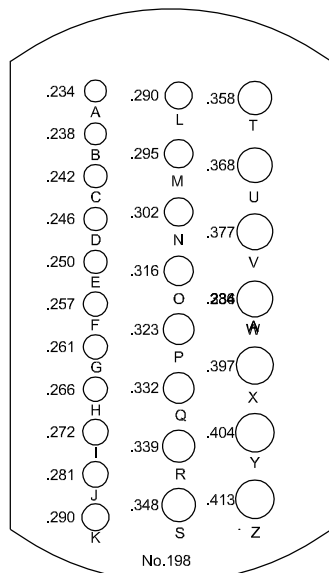

Number drills:

The number drill series consists of drills numbered from 1 to 80. The No.1 drill is the largest, with 5.791 mm diameter, and the No.80 drill is the smallest, with 0.35 mm diameter. (Table 2). There is no uniform variation in the drill diameters from number to number. To find the correct diameter of a number drill, refer to a drill Size Chart or a Hand-book. Number drill series are also known as 'wire gauge' series.

TABLE 2
Number drill sizes

No	Diameter	
	Inches	mm
1	.228	5.791
2	.221	5.613
3	.213	5.410
4	.209	5.309
5	.2055	5.220
6	.204	5.182
7	.201	5.105
8	.199	5.055
9	.196	4.978
10	.1935	4.915
11	.191	4.851
12	.189	4.801
13	.185	4.699
14	.182	4.623
15	.180	4.572
16	.177	4.496

No	Diameter	
	Inches	mm
17	.173	4.394
18	.1695	4.305
19	.166	4.216
20	.161	4.089
21	.159	4.039
22	.157	3.988
23	.154	3.912
24	.152	3.861
25	.1495	3.797
26	.147	3.734
27	.144	3.658
28	.1405	3.569
29	.136	3.454
30	.1285	3.264
31	.120	3.048
32	.116	2.946
33	.113	2.870
34	.111	2.819
35	.110	2.794
36	.1065	2.705
37	.104	2.642
38	.1015	2.578
39	.0995	2.527
40	.098	2.489
41	.096	2.438
42	.0935	2.375
43	.089	2.261
44	.086	2.184
45	.082	2.083
46	.081	2.057
47	.0785	1.994
48	.076	1.930
49	.073	1.854
50	.070	1.778
51	.067	1.702
52	.0635	1.613
53	.0595	1.511
54	.055	1.395

No	Diameter	
	Inches	mm
55	.052	1.321
56	.0465	1.181
57	.043	1.092
58	.042	1.067
59	0.41	1.041
60	.040	1.016
61	0.0390	1.00
62	0.0380	0.98
63	0.0370	0.95
64	0.0360	0.92
65	0.0350	0.90
66	0.033	0.85
67	0.032	0.82

No	Diameter	
	Inches	mm
68	0.031	0.79
69	0.0292	0.75
70	0.0280	0.70
71	0.0260	0.65
72	0.0240	0.65
73	0.0240	0.60
74	0.0225	0.58
75	0.0210	0.52
76	0.0200	0.50
77	0.0180	0.45
78	0.0160	0.40
79	0.0145	0.38
80	0.0135	0.35

Sharpening of drills (Grinding of drill)

Objective: At the end of this lesson you shall be able to

- sharpen drills on an off hand grinder .

Why cutting angle should be checked and resharpened?

Drills will lose the sharpness of the cutting edges due to continuous use.

Improper use of drills can also spoil the cutting edges. Worn out drills are to be re-sharpened on a grinder.

How to grind drills?

Before grinding, check for loading, glazing, and trueness of wheels and cracks or other damages. Dress and true the wheel, if necessary.

While grinding the shank, the other end of the drill is held lightly between the thumb and the first finger. (Fig 1)

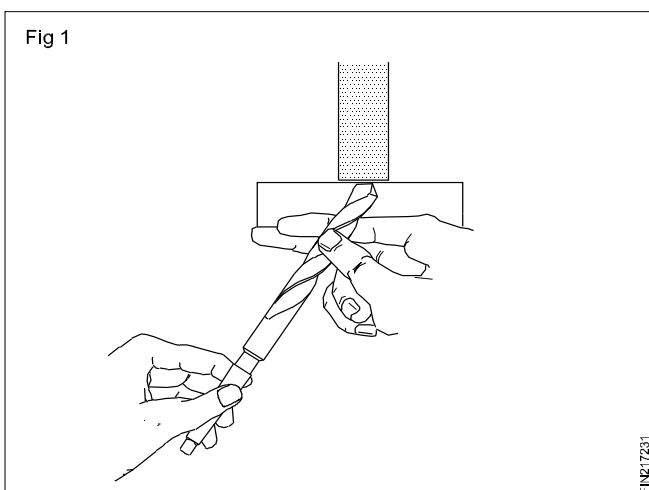

The hand near the point should be pivoted lightly on the tool-rest for easy manipulation. (Fig 2)

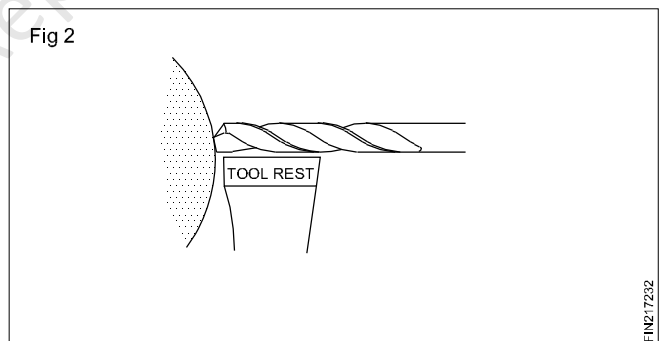

Hold the drill level and turn it to 59° to the face of the wheel so that the cutting edge is horizontal and parallel to the grinding wheel-face. (Fig 1)

Swing the shank of the drill slightly downward and towards the left. (Fig 3)

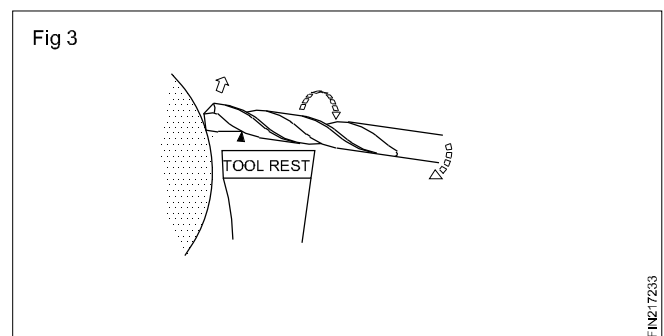

Rotate the drill to the right by turning it between the thumb and the finger.

This turning movement is not necessary for small drills.

While swinging down, apply a slight forward motion. This will help to form the clearance angle. (Fig 4)

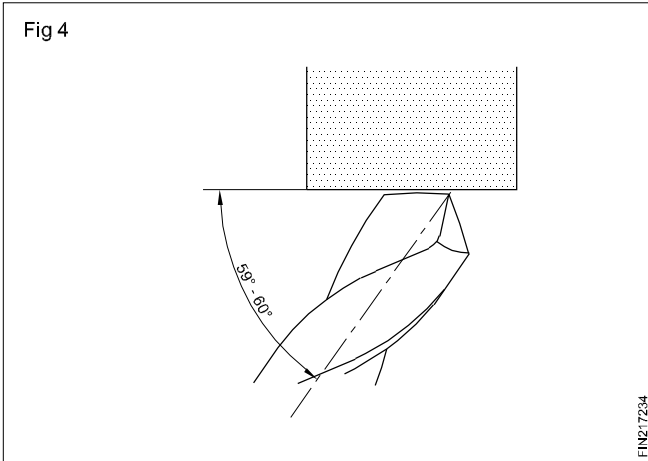

While swinging and turning the drill make sure you do not grind the other cutting edge.

All movements made to the drill i.e. angular turning swinging and forward movements, should be well coordinated. (Fig 5)

It should result in one smooth movement to produce a uniformly finished surface.

Repeat the process to re-sharpen the second cutting edge, using the same amount of drill movement uniformly.

How to check the angles of the cutting edges?

Check both the cutting edges with a drill angle gauge, for correctness of the lip angle and equality of the lip length. (Fig 6)

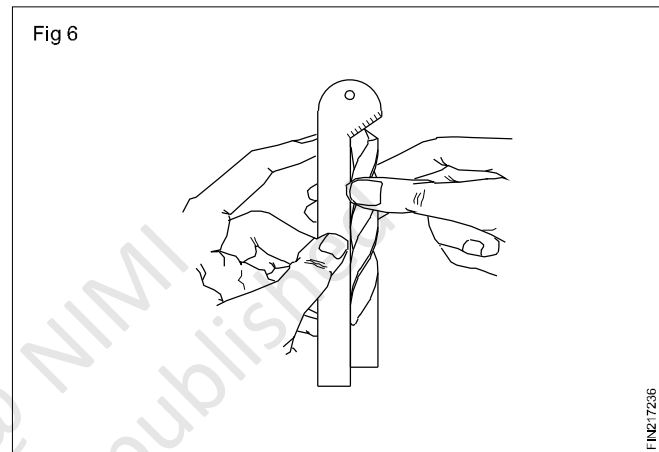
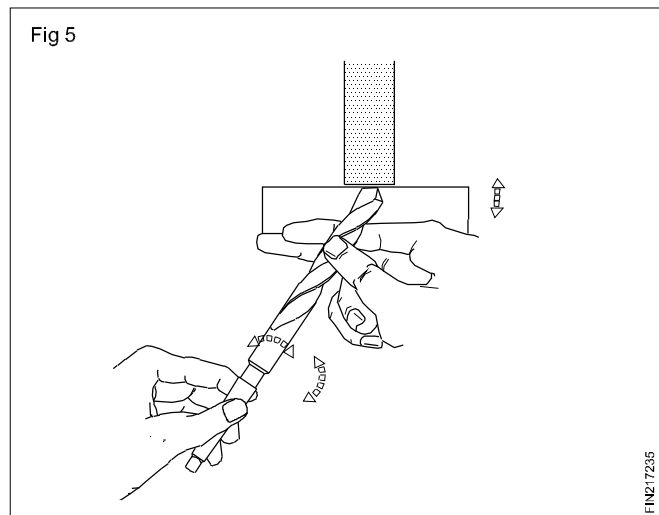

Check the lip clearance angle visually. The angle should be between 8° to 12° .

Fraction & Metric sizes of drills conversion table

Inches and millimetres										
(a) Inches to millimetres						Basic: 1 inch = 25.4 millimetres				
Inch	0	1/16	1/8	3/16	1/4	5/16	3/8	7/16		
0		1.59	3.18	4.76	6.35	7.94	9.53	11.11		
1	25.40	26.98	25.58	30.16	31.75	33.34	34.93	36.51		
2	50.80	52.39	53.97	55.56	57.15	58.74	60.33	61.91		
3	76.20	77.79	79.38	80.96	82.55	84.14	85.73	87.31		
4	101.60	103.19	104.78	106.36	107.95	109.54	111.13	112.71		
5	127.00	128.59	130.18	131.76	133.35	134.94	136.53	138.11		
6	152.40	153.99	155.58	157.16	158.75	160.34	161.93	163.51		
7	177.80	179.39	180.98	182.56	184.15	185.74	187.33	188.91		
8	203.20	204.79	206.38	207.96	209.55	211.14	212.73	214.31		
9	228.60	230.19	231.78	233.36	234.95	236.54	238.13	239.71		
10	254.00	255.59	257.18	258.76	260.35	261.94	263.53	265.11		
Inch	1/2	9/16	5/8	11/16	3/4	13/16	7/8	15/16		
0	12.70	14.29	15.88	17.46	19.05	20.64	22.23	23.81		
1	38.10	39.69	41.28	42.86	44.45	46.04	47.63	49.21		
2	63.50	65.09	66.68	68.26	69.85	71.44	73.03	74.61		
3	88.90	90.49	92.08	93.66	95.25	96.84	98.43	100.01		
4	114.30	115.89	117.48	119.06	120.65	122.24	123.83	125.41		
5	139.70	141.29	142.88	144.46	146.05	147.64	149.23	150.81		
6	165.10	166.69	168.28	169.86	171.45	173.04	174.63	176.21		
7	190.50	192.09	193.68	195.26	196.85	198.44	200.03	201.61		
8	215.90	217.49	219.08	220.66	222.25	223.84	225.43	227.01		
9	241.30	242.89	244.48	246.06	247.65	249.24	250.83	252.41		
10	266.70	268.29	269.88	271.46	273.05	274.64	276.23	277.81		
Example: $25 \frac{3}{4}'' = \left\{ \begin{array}{l} 20'' = (10 \times 2'' = 10 \times 50.8) = 508.0 \\ 5 \frac{3}{4}'' = 146.05 \end{array} \right\} = 654.05 \text{ mm}$										
(b) Millimetres to Inches						Basic: 1 Millimetre = 0.039369 inch				
mm	0	1	2	3	4	5	6	7	8	9
0		0.039	0.079	0.118	0.157	0.197	0.236	0.276	0.315	0.354
10	0.394	0.433	0.472	0.512	0.551	0.591	0.630	0.669	0.700	0.748
20	0.787	0.827	0.866	0.905	0.945	0.984	1.024	1.063	1.102	1.142
30	1.181	1.220	1.259	1.299	1.338	1.378	1.417	1.457	1.496	1.535
40	1.575	1.614	1.653	1.693	1.732	1.772	1.811	1.850	1.890	1.929
50	1.968	2.007	2.047	2.087	2.126	2.165	2.205	2.244	2.283	2.323
60	2.362	2.401	2.441	2.480	2.520	2.559	2.598	2.638	2.677	2.716
70	2.756	2.795	2.835	2.874	2.913	2.953	2.992	3.031	3.074	3.110
80	3.149	3.189	3.228	3.268	3.307	3.346	3.386	3.425	3.464	3.504
90	3.543	3.583	3.622	3.661	3.701	3.740	3.779	3.819	3.858	3.897
mm	0	100	200	300	400	500	600	700	800	900
0		3.94	7.87	11.81	15.75	19.68	23.62	27.56	31.49	35.43
1000	39.37	43.30	47.24	51.18	55.12	59.05	62.99	66.93	70.86	74.80
2000	78.74	82.67	86.61	90.55	94.48	98.42	102.36	106.30	110.23	114.17
3000	118.11	122.04	125.98	129.92	133.85	137.79	141.73	145.66	149.60	153.54
4000	157.47	161.41	165.35	169.29	173.22	177.16	181.10	185.03	188.97	192.91
5000	196.84	204.71	212.59	220.38	228.34	236.21	244.09	251.96	259.83	267.71
Example: $2256 \text{ mm} = \left\{ \begin{array}{l} 2200 \text{ mm} = 86.61'' \\ 56 \text{ mm} = 2.204'' \end{array} \right\} = 88.814''$										

Standard marking system for Grinding wheels

Objectives: At the end of this lesson you shall be able to

- interpret the marking on a grinding wheel
- specify a grinding wheel.

Introduction

Standard wheel - markings specify all the important wheel characteristics. The marking system comprises of seven symbols which are arranged in the following order. (Fig 1)

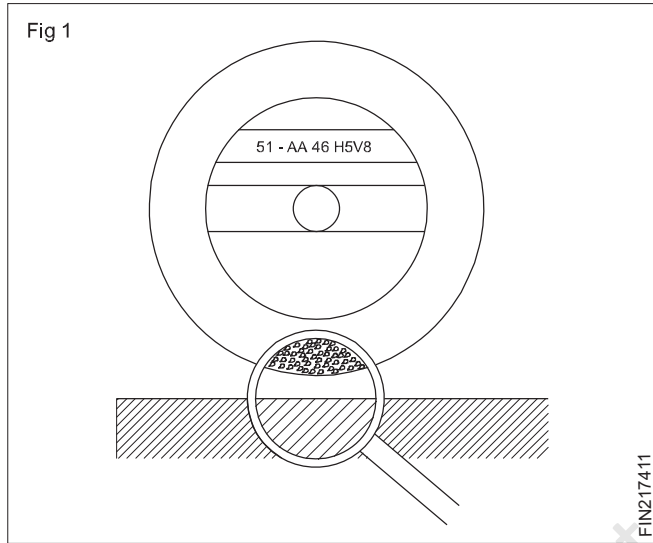

Example (Marking system)

51 - A 46

Specification of grinding wheels

A grinding wheel is specified by the standard wheel markings like diameter of the wheel, bore diameter of the wheel, thickness of the wheel type (Shape) of the wheel.

Example

32 A 46 H8V

250X20X32-

Straight wheel

Table 1 shows the relative position measuring of the marking system

TABLE 1

Position 0	Position 1	Position 2	Position 3	Position 4	Position 5	Position 6
Manufacturer's symbol for abrasive (Optional)	Type of abrasive grit size	Grain size	Grade	Structure (Optional)	Type of bond	Manufacturer's own mark (Optional)

51

A

46

H

5

V

8

Chart illustrating the standard marking system is : 551-1966 (Table - 2)

TABLE 2

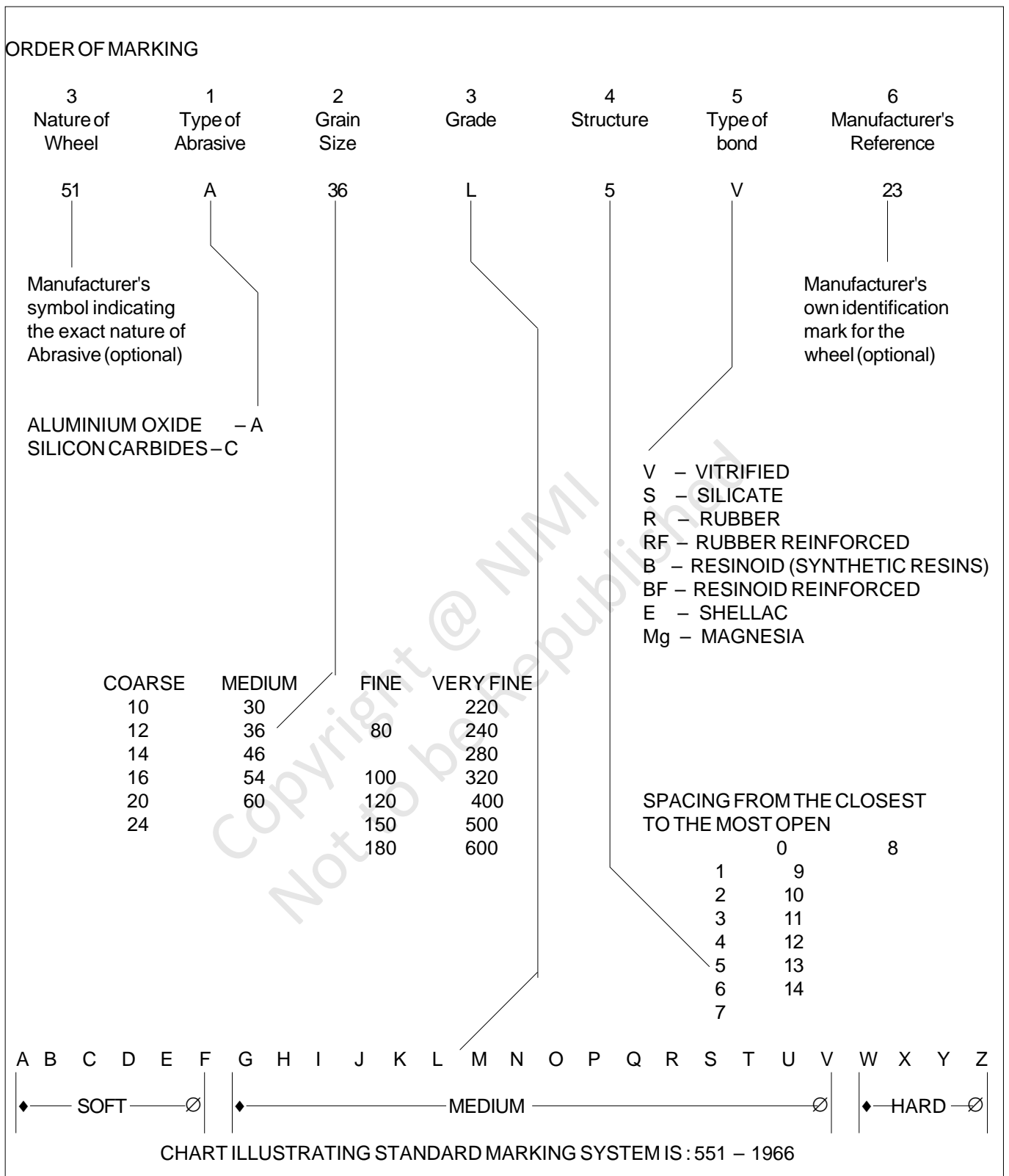

Construction of the grinding wheel

Objectives: At the end of this lesson you shall be able to

- state the different types of abrasives and their uses
 - state the different grain sizes and their uses
 - state the different grades of grinding wheels
 - state the structure of a grinding wheel
 - name the bonding materials used for grinding wheels.
-

In order to suit the grinding wheel for different work situations, the features such as abrasive, grain size, grade, structure and bonding materials can be varied.

A grinding wheel consists of the abrasive that does the cutting, and the bond that holds the abrasive particles together.

Abrasives

There are two types of abrasives.

Natural abrasive

Artificial abrasive

The natural abrasives are emery and corundum, These are impure forms of aluminium oxide.

Artificial abrasives are silicon carbide and aluminium oxide.

The abrasives are selected depending upon the material being ground.

'Brown' aluminium oxide is used for general purpose grinding of tough materials.

'White aluminium oxide is used for grinding ferrous and ferrous alloys.

'Green' silicon carbide is used for very hard materials with low tensile strength such as cemented carbides.

Grain size (Grit size)

The number indicating the size of the grit represents the number of openings in the sieve used to size the grain. The larger the grit size number, the finer the grit.

Grade

Grade indicates the strength of the bond and, therefore, the 'hardness' of the wheel. In a hard wheel the bond is strong, and securely anchors the grit in place and, therefore, reduces the rate of wear. In a soft wheel, the bond is weak and the grit is easily detached resulting in a high rate of wear.

Structure

This indicates the amount of bond present between the individual abrasive grains and the closeness of the individual grains to each other. An open structure wheel will cut more freely. That is, it will remove more metal in a given time and produce less heat. It will not produce such a good finish as a closely structured wheel.

Bond

The bond is the substance which, when mixed with abrasive grains, hold them together, enabling the mixture to be shaped to the form of the wheel, and after suitable treatment to take on the necessary mechanical strength for its work. The degree of hardness possessed by the bond is called the 'grade' of the wheel, and indicates the ability of the bond to hold the abrasive grains in the wheel. There are several types of bonding materials used for making wheels.

Vitrified bond

This is the most widely used bond. It has high porosity and strength which makes this type of wheel suitable for high rate of stock removal. It is not adversely affected by water, acid, oils or ordinary temperature conditions.

Silicate bond

Silicate wheels have a milder action and cut with less harshness than vitrified wheels. For this reason they are suitable for grinding fine edge tools, cutters etc.

Shellac bond

This is used for heavy duty, large diameter wheels where a fine finish is required. For example, the grinding of millrolls.

Rubber bond

This is used where a small degree of flexibility is required on the wheel as in the cutting off wheels.

Resinoid bond

This is used for speed wheels. Such wheels are used in foundries for dressing castings. Resinoid bond wheels are also used for cutting off. They are strong enough to withstand considerable abuse.

Wheel inspection and wheel mounting

Objectives: At the end of this lesson you shall be able to

- brief steps involved in grinding wheel inspection
- state the procedure for mounting of grinding wheel.

Wheel inspection

The wheel selected may have been damaged during transport or storage and must be carefully inspected before use.

Visual inspection (Fig 1)

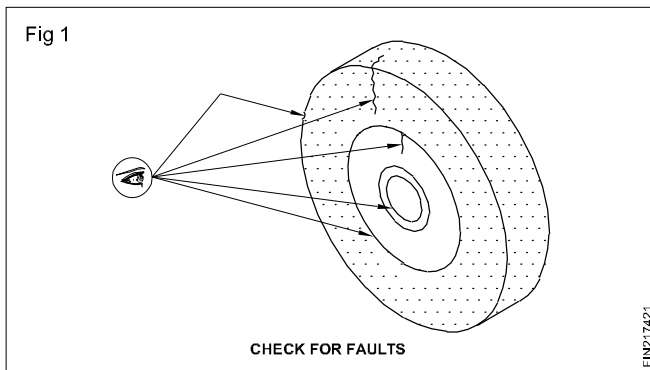

Look for

- Broken or chipped edges.
- Cracks
- Damaged mounting bushing
- Damaged paper washers

Testing for cracks (Fig 2)

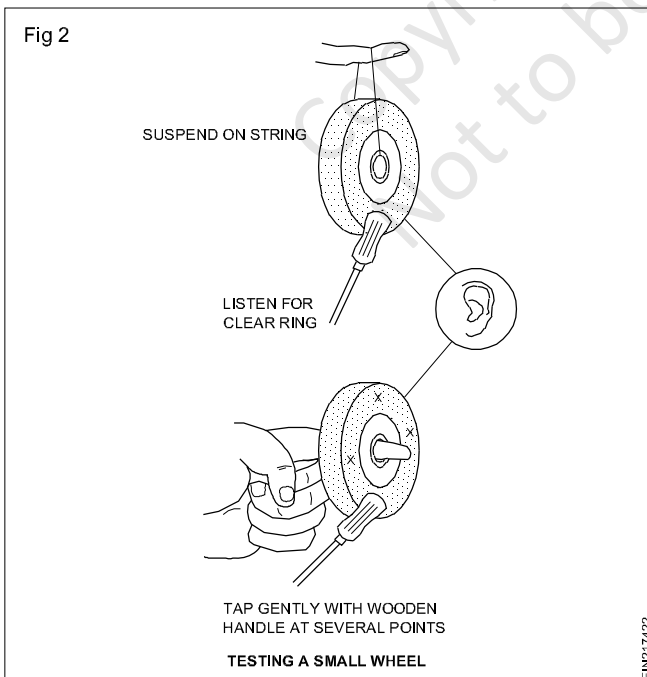

Test a wheel for cracks by the following method

- Suspend the wheel on a piece of string or support it with one finger through the bushing.
- Allow the wheel to hang free.
- Tap the wheel with a non-metallic object such as a small wooden mallet or tool handle.
- A clear ringing sound indicates that the wheel is not cracked.
- A dull sound means that the wheel is cracked and must not be used.

Warning

Discard any wheel that:

- Shows any sign of damage.
- Does not ring clearly when struck.

If you are in doubt, do not use the wheel. Clearly mark it and seek advice from your supervisor. (Fig 3)

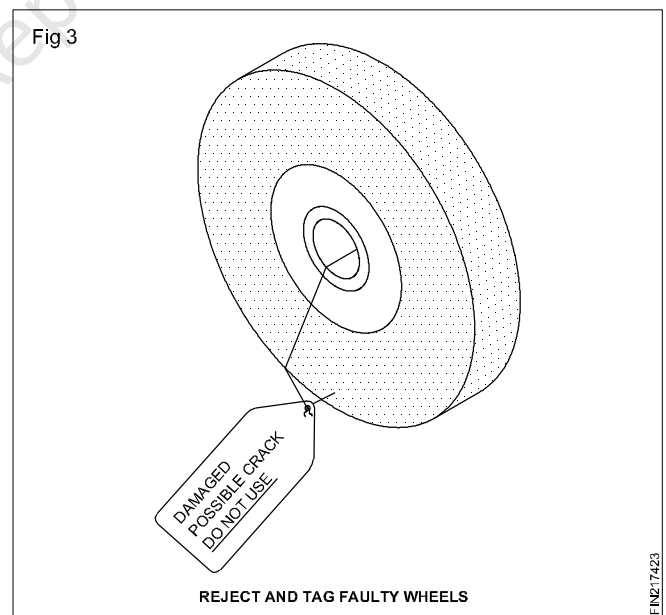

Mounting the grinding wheel (Fig 4)

For correct and safe operation of a grinding machine it is essential to mount the grinding wheel correctly on the spindle.

Before fitting a new wheel, make sure that the spindle is completely clean and free from surface irregularities.

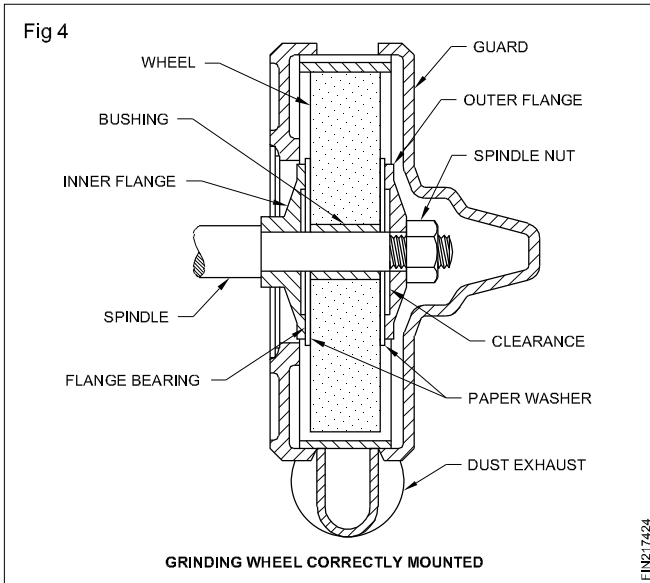

The spindle of the grinding machine includes an inner flange, an outer flange and a nut threaded on the spindle to hold the grinding wheel in position.

The inner flange must be fixed to rotate with the spindle.

Each flange has a dished face towards the surface of the wheel and has a true bearing surface at its area of contact.

Suitable paper discs are normally fitted to the wheel by the manufacturer.

Mounting procedure (Fig 5)

Mount the wheel on the spindle of the grinding machine as follows:

Check that the spindle surface is clean and free of irregularities. Clean with a dry cloth, if necessary.

Check that the inner flange is fixed to the spindle and that its bearing surface is clean and true.

Check that the wheel bush surface is clean and that it can fit easily, but not loosely, onto the spindle. Clean the bush before fitting the wheel on the spindle, if necessary.

Check that each side of the grinding wheel is fitted with a soft paper disc of slightly larger diameter than the spindle flanges.

Check that the diameter of each spindle flange is at least one third the diameter of the grinding wheel.

Fit the grinding wheel to the spindle and place the outer spindle flange in position.

Tighten the spindle nut against the outer spindle flange with a spanner of the correct size.

Replace the wheel guard correctly

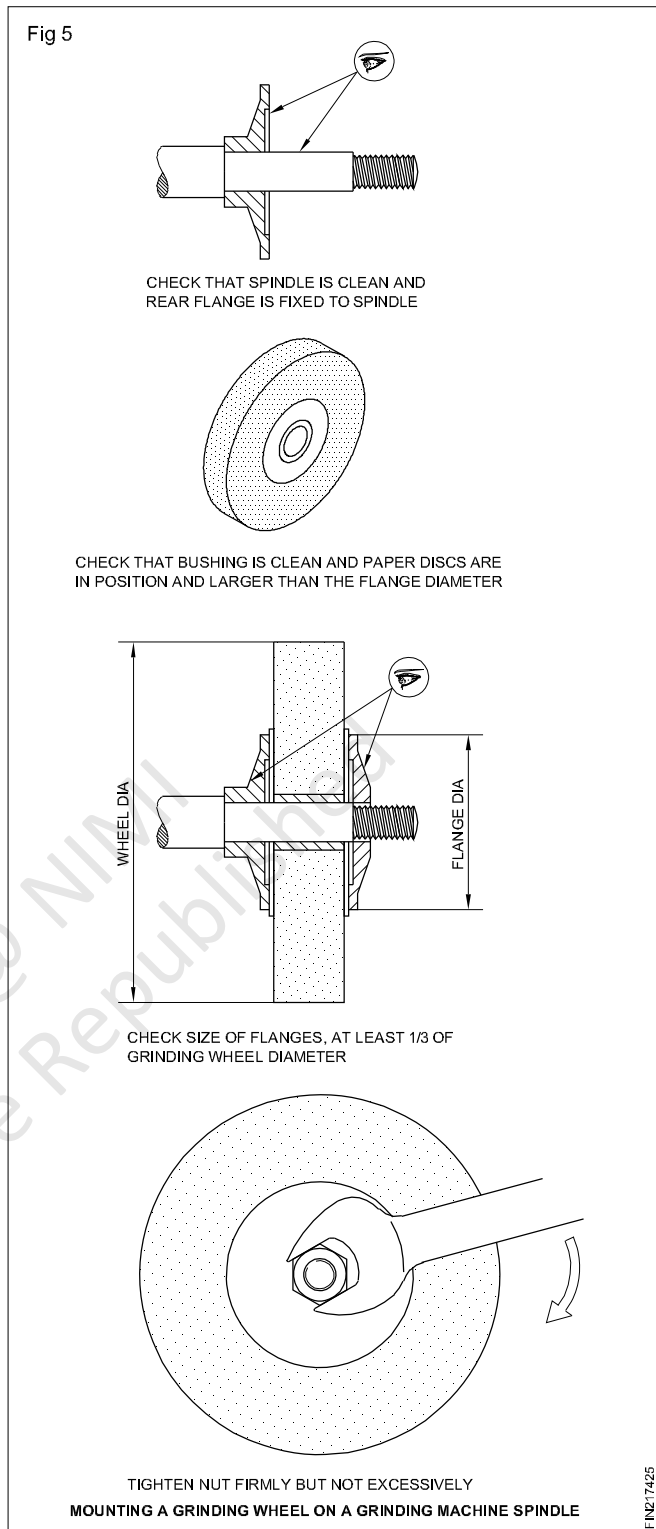

Caution

The nut should only be tightened sufficiently to hold the wheel firmly. If it is tightened excessively, the wheel may break.

The nut is threaded onto the spindle in a direction opposite to the direction of rotation of the spindle.

- Run the wheel at its recommended speed in the grinding machine for at least a minute. Do not use the wheel during this period.

Points to note

Study these illustrations carefully and note the points to watch when mounting grinding wheels. (Fig 6)

Washer of compressible material such as card board, leather, rubber etc, not more than 1.5mm thick should be fitted between the wheel and flanges. This prevents any unevenness of the wheel surface is balanced and the tight joint is obtained.

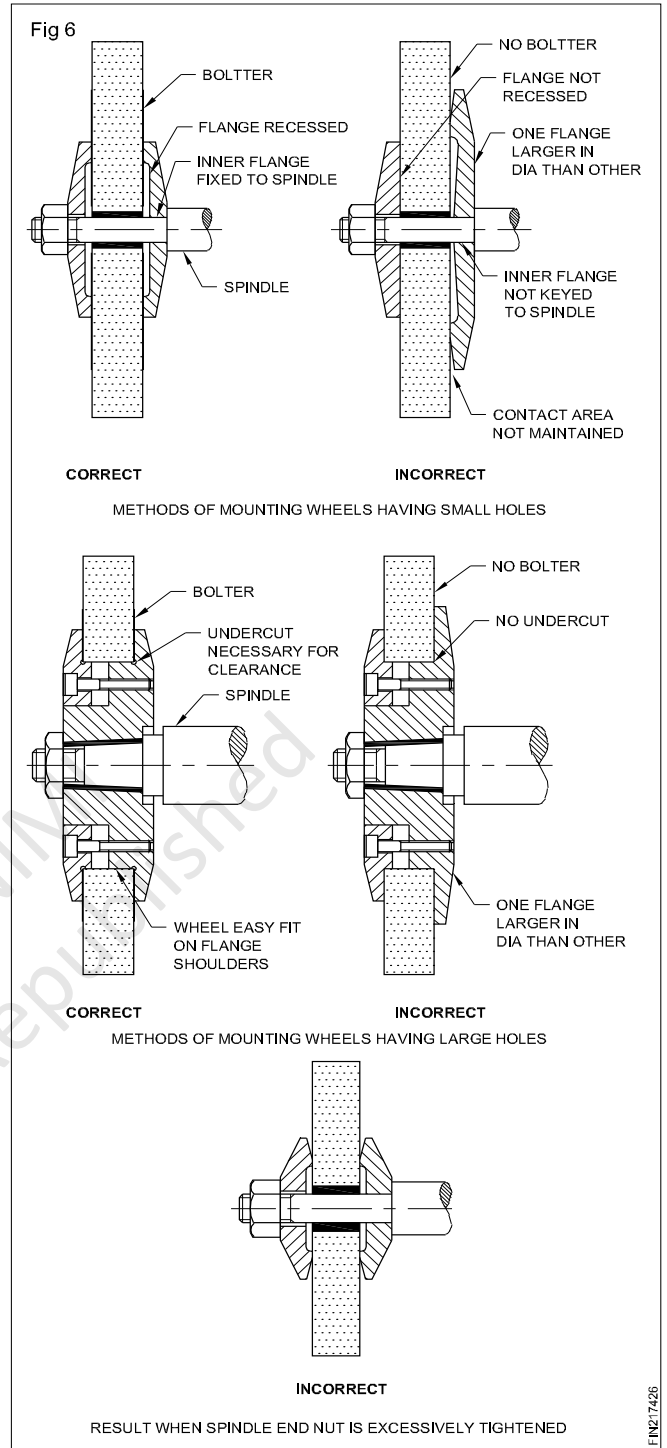

Grinding wheel dressing

Objectives : At the end of this lesson you shall be able to

- differentiate between loading and glazing
- state the effects of loading and glazing
- differentiate between dressing and truing.

Grinding wheels become inefficient due to two main causes known as loading and glazing.

Loading

When soft materials such as aluminium, copper, lead etc. are ground, the metal particles get clogged in the pores of the wheel. This condition is called loading. (Fig 1)

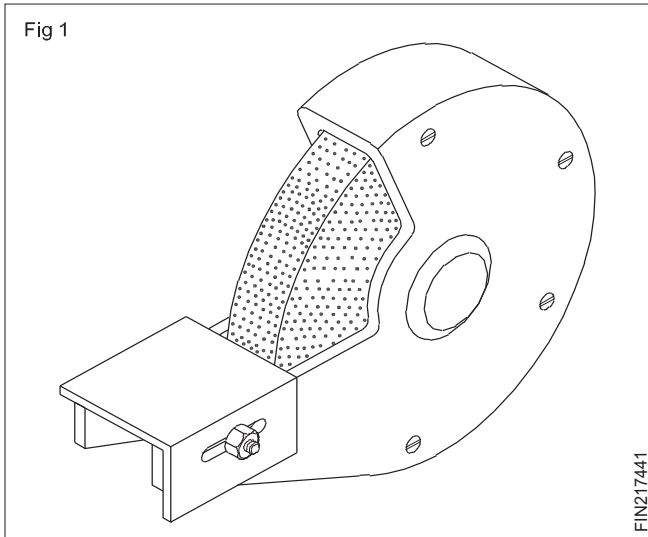

Glazing

When a surface of the wheel develops a smooth and shining appearance, it is said to be glazed. This indicates that the wheel is blunt, i.e. the abrasive grains are not sharp.

When such grinding wheels are used, there is a tendency to exert extra pressure in order to make the wheels cut.

Grinding wheel dressers

Objectives: At the end of this lesson you shall be able to

- name the common types of wheel dressers
- state the uses of each type of wheel dressers.

The wheel dressers used for off-hand grinders are star wheel dressers (Fig 1) (Huntington type wheel dresser) and diamond dressers.

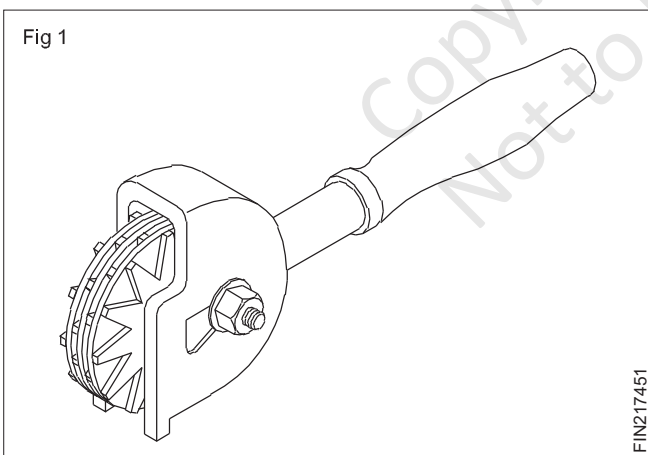

The star wheel dresser consists of a number of hardened star-shaped wheels mounted on a spindle at one end and a handle at the other end.

While dressing, the star wheel is pressed against the face of the revolving grinding wheel. The star wheel revolves and digs into the surface of the grinding wheel. This releases the wheel loading and dull grains, exposing sharp new abrasive grains.

Excessive pressure on the grinding wheel will lead to the fracture of the wheel, excessive heating of the wheel, weakening of bonding of the wheel and bursting of the wheel.

Dressing

The purpose of dressing is to restore the correct cutting action of the wheel. Dressing removes the clogs on the surface of the wheel and the blunt grains of the abrasive, exposing the new sharp abrasive grains of the wheel which can be cut and brought to shape efficiently.

Truing

Truing refers to the shaping of the wheel to make it run concentric with the axis. When a new grinding wheel is mounted, it must be trued before use. The cutting surface of a new wheel may run out slightly due to the clearance between the bore and the machine spindle. Grinding wheels, which are in use, also can run out of true, due to uneven loading while grinding.

Dressing and truing are done at the same time.

Star wheels are useful for pedestal grinders in which a precision finish is not expected.

Star wheel dressers should be used only on wheels which are large enough to take the load.

Diamond Dressers (Fig 2)

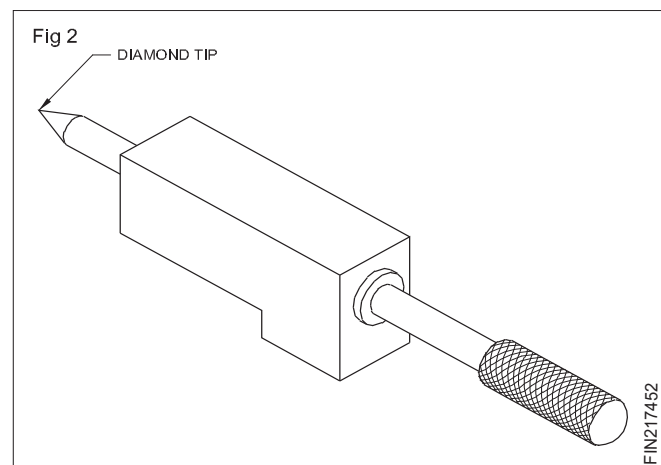

Bench type off-hand grinders used for sharpening cutting tools are usually fitted with smaller and rather delicate wheels.

These wheels are dressed and trued with diamond dressers.

Diamond dressers consist of a small diamond mounted on a holder which can be held rigidly on the work-rest.

How to use a wheel dresser (Fig 3)

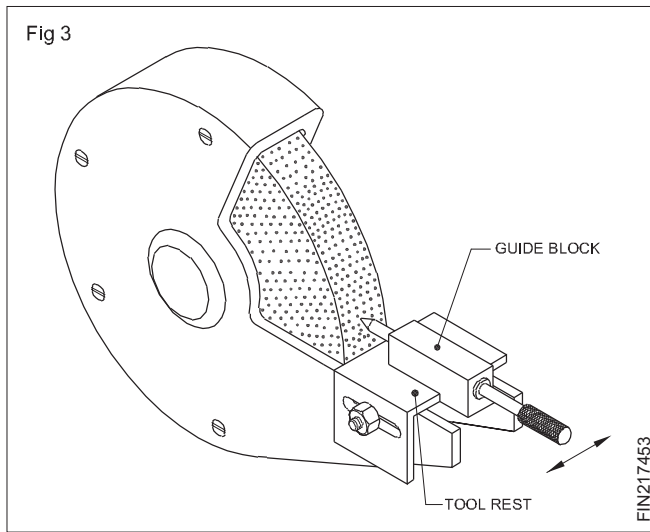

For dressing and truing, the dresser is slowly brought in to contact with the wheel face and moved across.

The finish obtained depends on the rate at which the dresser is moved across the face.

For roughing, the dresser is moved faster.

For fine finish, the dresser is moved slowly.

Roughing will be efficient with a dresser that has a sharp point, while, for fine finishing, a blunt diamond dresser is more suitable.

Abrasive stick

When only a light dressing is required, abrasive sticks can also be used. There are abrasive materials made in the form of sticks for the convenience of handling.

Diamond dressers, if moved too slowly, can glaze the wheel.

Off-hand grinding with bench and pedestal grinders

Objectives: At the end of this lesson you shall be able to

- state the purposes of off-hand grinding
- name the machines with which off-hand grinding is done
- state the features of bench and pedestal grinders.

Off-hand grinding is the operation of removing material which does not require great accuracy in size or shape. This is carried out by pressing the workpiece by hand against a rotating grinding wheel.

Off-hand grinding is performed for rough grinding of jobs and sharpening of scribers, punches, chisels, twist drills, single point cutting tools etc.

Off-hand grinders are fitted to a bench and pedestal (Figs 1 and 2)

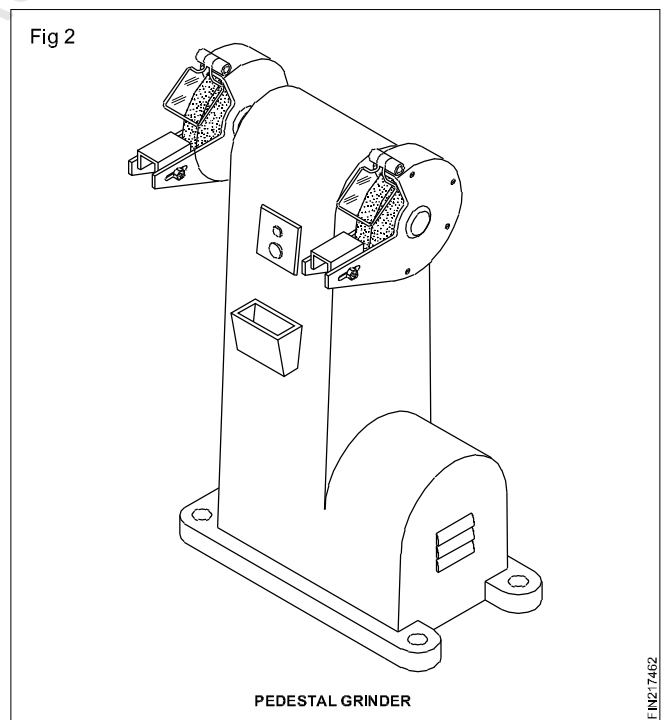
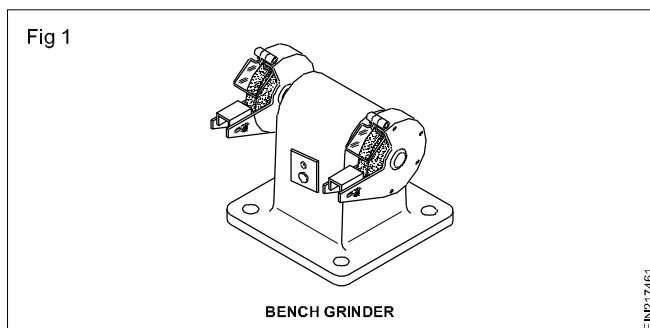

Bench grinders: Bench grinders are fitted on a bench or table, and are useful for light duty work.

Pedestal grinders: Pedestal grinders are mounted on a base (pedestal), which is fastened to the floor. They are used for heavy duty work.

These grinders consist of an electric motor and the spindle for mounting the grinding wheels. On one end of the spindle a coarse-grained wheel is fitted, and on the other end, a fine-grained wheel. For safety while working, wheel guards are provided.

A coolant container (Fig 3) is provided for frequent cooling of the work.

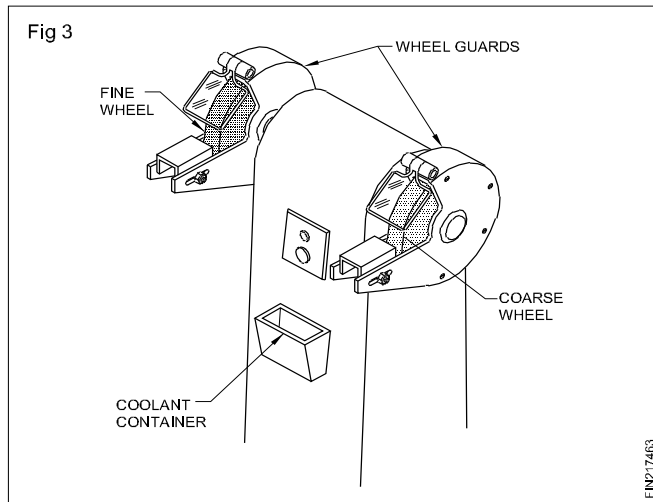

Adjustable work-rests are provided for both the wheels to support the work while grinding. These work-rests must be set very close to the wheels. (Fig 4)

Extra eyeshields are also provided for the protection of the eyes. (Fig 4)

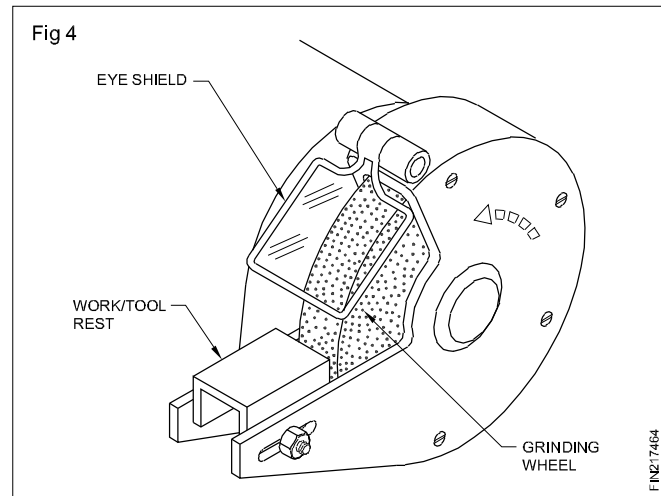

Radius/Fillet gauge, feeler gauge, hole gauge

Objectives: At the end of this lesson you shall be able to

- state what is radius and fillet gauge
- mention the sizes and uses of feeler gauge.

Radius and fillet gauges: Components are machined to have curved formation on the edges or at the junction of two steps. Accordingly they are called radius and fillets. The size of the radius is normally provided on a drawing. The gauges used to check the radius formed on the edges of diameters are fillet and the gauges used to check the fillets are called fillet gauges.

They are made of hardened sheet metal each to a precise radius. They are used to check the radii by comparing the radius on a part with the radius of the gauges.

Fig 1 shows the application of radius gauge to check the radius formed externally. Fig 2 shows the application of a fillet gauge to check the fillet formed on a turned component. The other typical applications are:

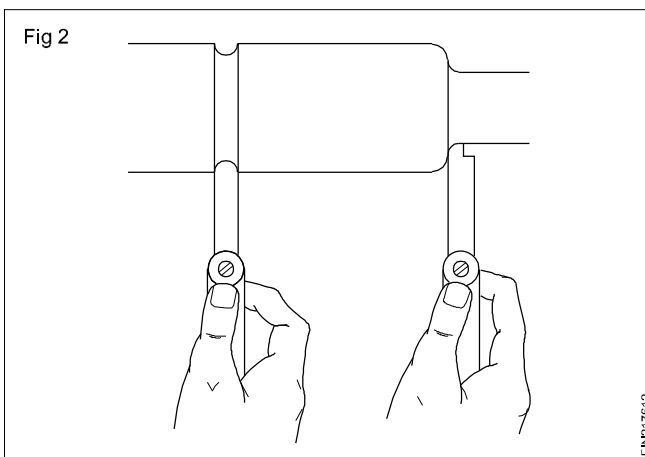
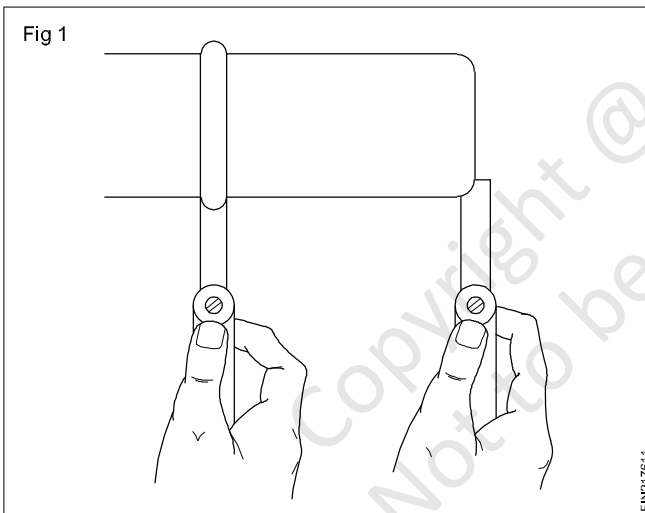

- Checking the corner radius of a part being filed to shape. (Fig 3)

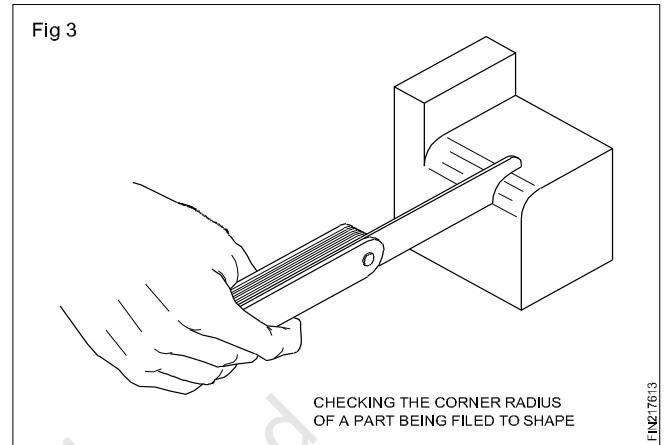

- Checking a radius formed by a milling cutter. (Fig 4)

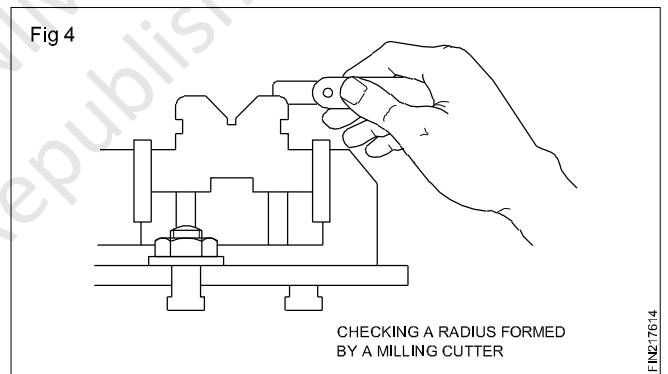

The radius and fillet gauges are available in sets of several blades which fold into a holder when not in use. (Fig 5)

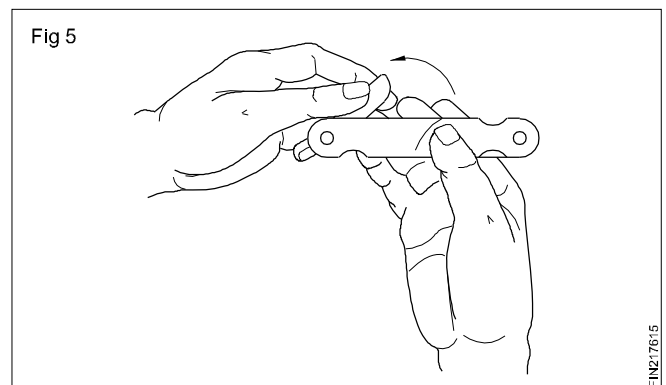

Some sets have provisions to check the radius and fillet on each blade. (Fig 6)

And some sets have separate sets of blades to check the radius and fillet. (Fig 7)

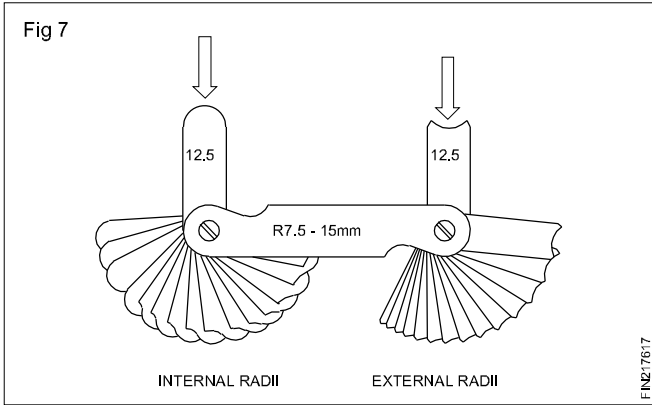
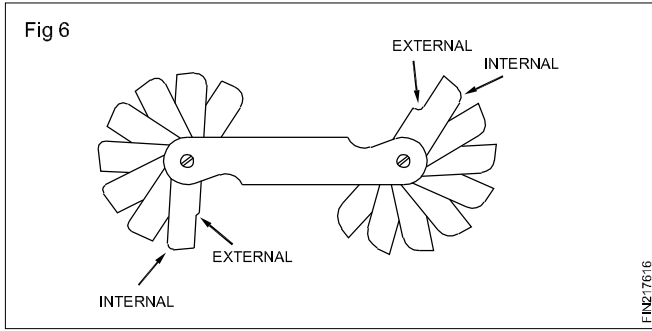

Each blade can be swung out of the holder separately, and has its size engraved on it. (Fig 8)

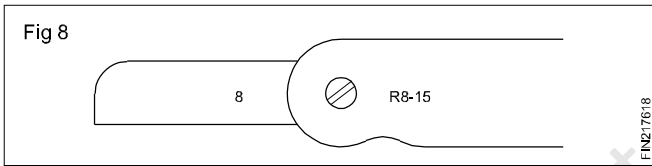

Fillet gauges are available in sets to check the radii and fillets from:

1 to 7 mm in steps of 0.5 mm

7.5 to 15 mm in steps of 0.5 mm

15.5 to 25 mm in steps 0.5 mm.

Individual gauges are also available. They usually have internal and external radii on each gauge and are made in sizes from 1 to 100 mm in steps of 1 mm. (Fig 9)

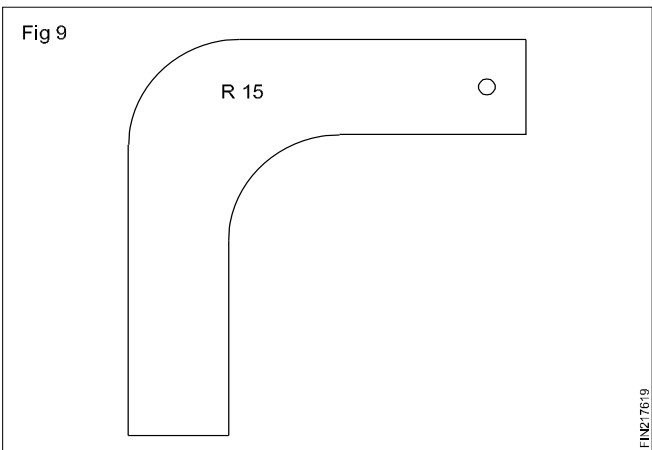

Before using the radius gauge, check that it is clean and undamaged.

Remove burrs from the workpiece.

Select the leaf of the gauge from the set corresponding to the radius to be checked.

Figure 10 shows that the radius of the fillet and that of the external radius are smaller than the gauge.

Try a smaller gauge to determine the radius dimension.

File or machine the workpiece if it has to be of the radius of the gauge.

Figure 11 shows that the radius of the fillet and that of the external radius are larger than the gauge.

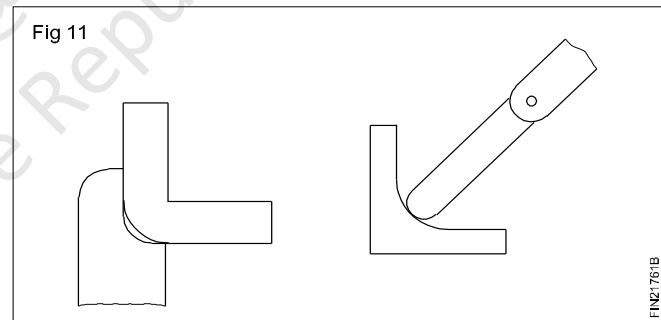
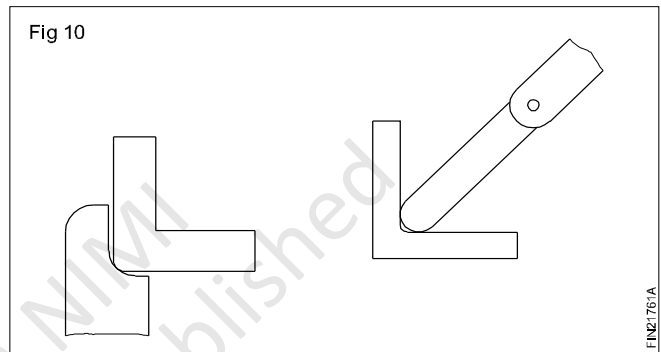

Try a larger gauge if you need to find the radius dimension.

Figure 12 shows the workpiece having the same radius as that of the gauge that is being used for checking.

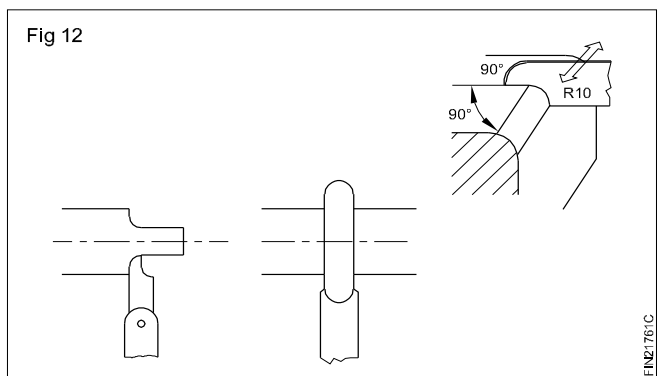

Feeler gauge and uses

Features: A feeler gauge consists of a number of hardened and tempered steel blades of various thicknesses mounted in a steel case. (Fig 13)

The thickness of individual leaves is marked on it. (Fig 13)

B.I.S. Set: The Indian Standard establishes four sets of feeler gauges Nos. 1, 2, 3 and 4 which differ by the number of blades in each and by the range of thickness (minimum is 0.03 mm to 1 mm in steps of 0.01 mm). The length of the blade is usually 100 mm.

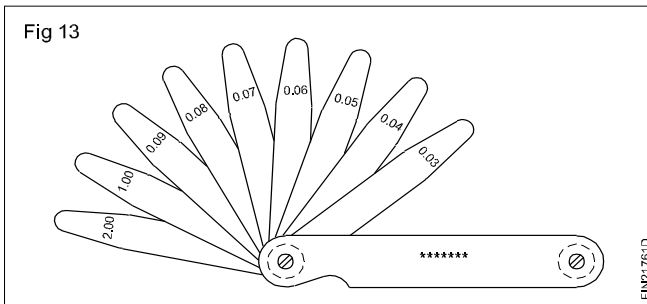

Example

Set No.4 of Indian Standard consists of 13 blades of different thicknesses.

0.03, 0.04, 0.05, 0.06, 0.07, 0.08, 0.09, 0.10, 0.15, 0.20, 0.30, 0.40, 0.50.

The sizes of the feeler gauges in a set are carefully chosen in order that a maximum number of dimensions can be formed by building up from a minimum number of leaves.

The dimension being tested is judged to be equal to the thickness of the leaves used, when a slight pull is felt while withdrawing them. Accuracy in using these gauge requires a good sense of feel.

Feeler gauges are used:

- To check the gap between the mating parts
- To check and set the spark plug gaps
- To set the clearance between the fixture (setting block) and the cutter/tool for machining the jobs
- To check and measure the bearing clearance, and for many other purposes where a specified clearance must be maintained. (Fig 14)

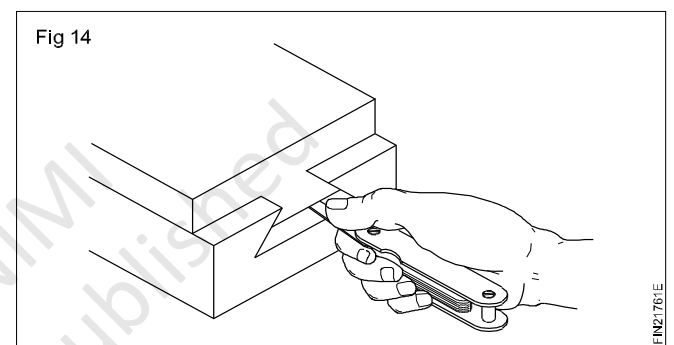

Telescopic gauge

Objectives : At the end of this lesson you shall be able to

- name the parts of a telescopic gauge
- state the constructional features of telescopic gauges
- state the ranges of telescopic gauges.

Telescopic gauges are popular for fine work as they are very rigid and have a better 'feel'.

Uses

Used for measuring the sizes of holes, slots and recesses.

Construction (Figs 1 & 2)

Telescopic gauges are 'T' shaped. They consist of a pair of telescopic legs or plungers connected to a handle. The plungers are spring-loaded to force them apart. After inserting the gauge in a hole or slot, it can be locked in position by turning the knurled handle. It may then be withdrawn from the hole and measured with a micrometer. (Fig 3)

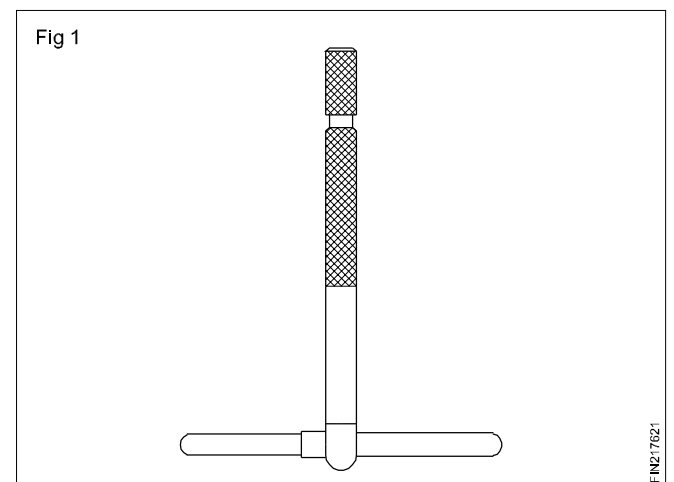

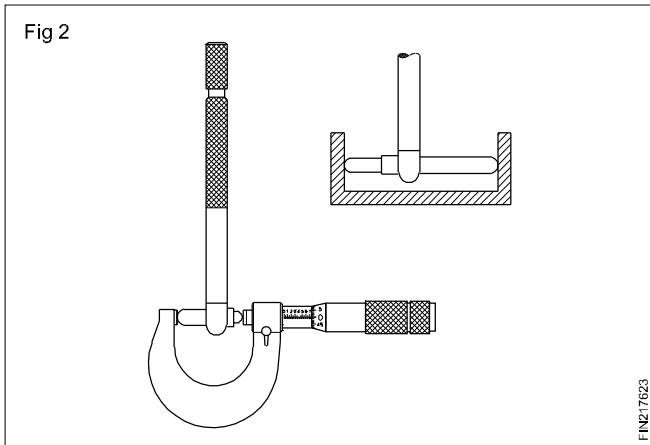
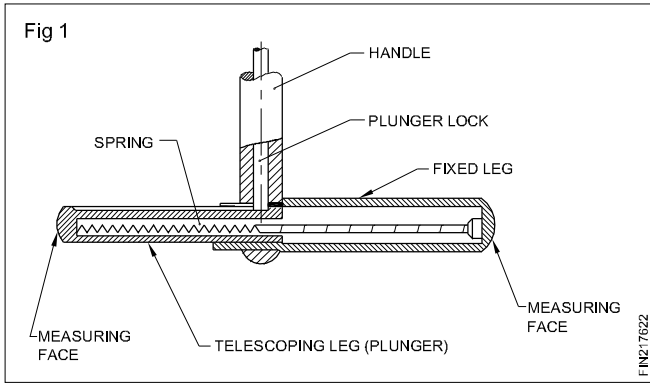

Telescopic gauges are available in a set of 6 nos, to measure holes from 8 mm to 150 mm. (as per MITUTOYO - Series 155)

No.1 8.0 mm to 12.7 mm

No.2 12.7 mm to 19.0 mm

No.3 19.0 mm to 32.0 mm

No.4 32.0 mm to 54.0 mm

No.5 54.0 mm to 90.0 mm

No.6 90.0 mm to 150.0 mm

Small hole gauges

Objectives : At the end of this lesson you shall be able to

- identify the parts of a small hole gauge
- state the construction of a small hole gauge
- state the ranges of small hole gauges.

Telescopic gauges are not suitable for measuring holes below 9 mm. For measuring smaller holes and slots, small hole gauges are used.

Construction (Fig 1)

A small hole gauge consists of a tube having holes on the opposite sides at one end where hardened balls are fixed. The other end of the tube has an external thread. A screwed thimble is fixed with the threaded tube. A plunger with a tapered end, and spring-loaded, is inserted in the tube and tightened with the screwed thimble.

At the end of the thimble a knurled handle is fitted. While rotating the knurled handle in a clockwise direction the plunger moves forward up, and pushes the balls out to contact the surfaces.

A small hole gauge is an instrument used for indirect measurement, while a micrometer is usually used for measuring the sizes directly.

Small hole gauges are available in a set of 4 numbers to measure holes from 3 mm to 13 mm. (as per MITUTOYO - Series 154)

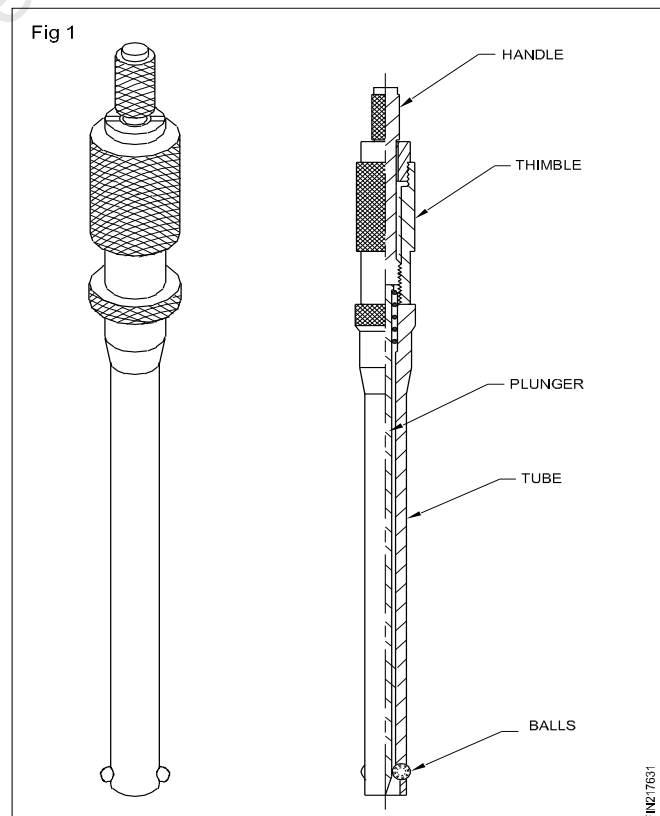

- No.1 3 mm to 5 mm
- No.2 5 mm to 7.5 mm
- No.3 7.5 mm to 10 mm
- No.4 10 mm to 13 mm

Care and Maintenance of Feeler, radius and hole gauges

Immediately after use, close funned out feeler gauge blades. This should be done by grouping smaller blades against the consecutively larger sizes for support. This will prevent the thinner blades bending when they are closed into the case.

Feeler gauges should be cleaned with an oily cloth before storage to prevent rust.

Wonkee Donkee recommends that you keep the blades closed at all times, other than when in actual use, to prevent damage. Open - Measure - Close. The blades should only be out for as long as it takes to measure or set the gap. Tighten the adjusting screw, if there is one, for additional security.

Radius gauges can be covered in an oil-based spray as a preventive measure against rust during storage. If a radius gauge becomes rusty, the folding mechanism may seize up. Further problems include the compromised accuracy of the gauge's measurement. The once precisely machined radius may develop irregularities because of corrosion.

Close away blades into the case carefully after use. This ensures the blades do not become bent or misshapen when the gauge is not in use. Radius gauge blades with fine measuring surfaces are often bought in assortment to be sure to use the plastic sleeve casing which allows neat and orderly storage.

Some types of small hole gauges have flattened ball ends to permit use in shallow holes and recesses. Be care. Observe the following practices for the care and upkeep of small hole gauges:

- Coat metal parts of small hole gauges with a light film oil to prevent rust.
- Store gauges in separate containers.
- Keep graduation and markings clean and legible.
- Do not drop small hole gauges. Small nicks and scratches will result in inaccurate measurement

Copyright @ NIM
Not to be Republished

Pig Iron

Objectives: At the end of this lesson you shall be able to

- name the commonly used ferrous metals
- state the main raw materials used for the smelting of pig-iron and their uses
- name the ores used for producing pig-iron
- state the constructional features of a blast furnace
- state the properties and uses of pig-iron.

Metals which contain iron as a major content are called ferrous metals. Ferrous metals of different properties are used for various purposes.

The ferrous metals and alloys used commonly are:

- Pig-iron
- Cast iron
- Wrought iron
- Steels and alloy steels.

Different processes are used to produce iron and steel.

Pig-iron is obtained by the chemical reduction of iron ore. This process of reduction of the iron ore to pig-iron is known as SMELTING.

The main raw materials required for producing pig-iron are:

- Iron ore
- Coke
- Flux.

Iron ore

The types of iron ores

- Magnetite
- Hematite
- Limonite
- Carbonate.

These ores contain iron in different proportions and are 'naturally' available.

Coke

Coke is the fuel used to give the necessary heat to carry on the reducing action. The carbon from the coke in the form of carbon monoxide combines with the iron ore to reduce it to iron.

Flux

This is the mineral substance charged into a blast furnace to lower the melting point of the ore, and it combines with the non-metallic portion of the ore to form a molten slag.

Limestone is the most commonly used flux in the blast furnace.

Blast furnace (Fig 1)

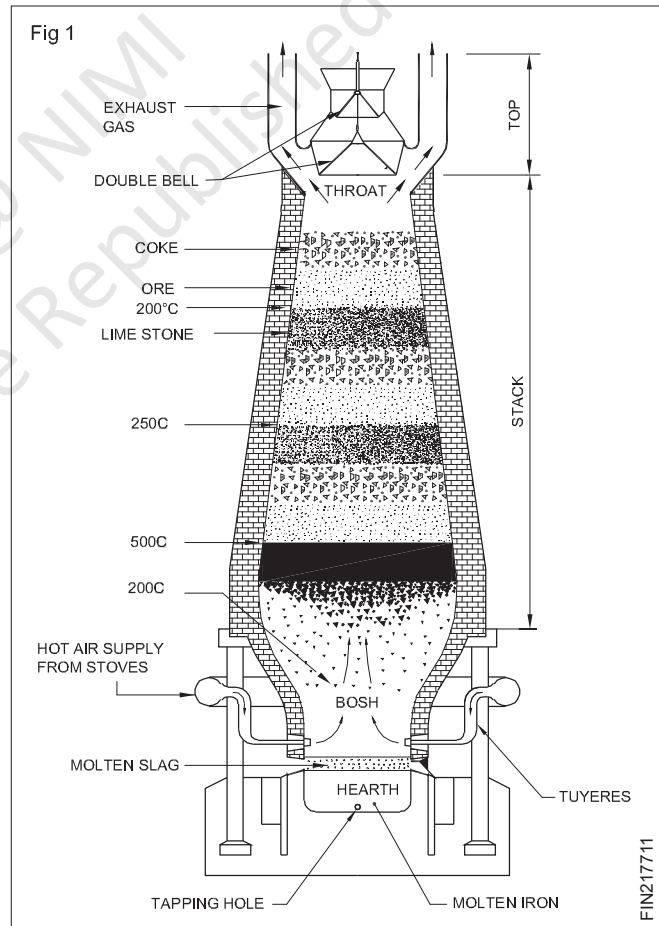

The furnace used for smelting iron ore is the blast furnace. The product obtained from smelting in the blast furnace is pig-iron. The main parts of the blast furnace are:

- Throat
- Stack
- Bosh

- Hearth
- Double bell charging mechanism
- Tuyeres.

Smelting in a blast furnace

The raw materials are charged in alternate layers of iron ore, coke and flux in the furnace by means of a double bell mechanism. (Figs 1 & 2)

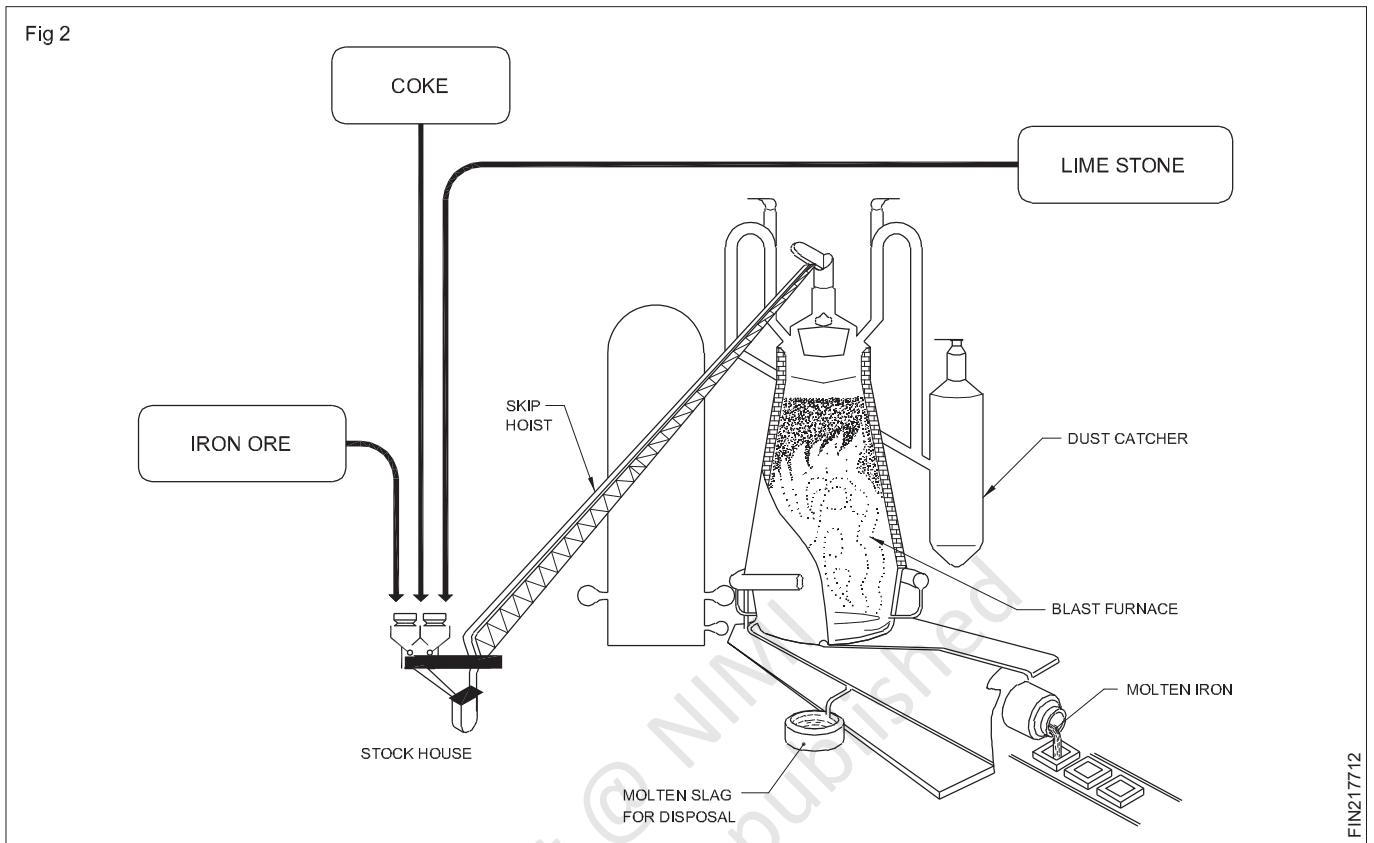

The hot blast is forced into the furnace through a number of nozzles (Fig1) called tuyeres.

The temperature of the furnace just above the level of the tuyeres (melting zone) is between 1000° C to 1700° C when all the substances start melting.

The limestone, which serves as a flux, combines with the non-metallic substances in the ore to form a molten slag which floats on the top of the molten iron. The slag is tapped off through the slag hole.

The molten iron is tapped at intervals through a separate tapping hole.

The molten iron may be cast in pig beds or used in other processing plants for steel making.

Properties and use of pig-iron

Pig-iron absorbs varying amounts of carbon, silicon, sulphur, phosphorus and manganese during the smelting process. A high amount of carbon makes the pig-iron very hard and brittle, and unsuitable for making any useful article.

Pig-iron is, therefore, refined and remelted and used to produce other varieties of iron and steel.

Cast iron (types)

Objectives: At the end of this lesson you shall be able to

- name the different types of cast iron
- state the properties of each type of cast iron
- state the uses of each type of cast iron.

Cast iron is an alloy of iron, carbon and silicon. The carbon content ranges from 2 to 4%.

Types of cast iron

The following are the types of cast iron.

- Grey cast iron
- White cast iron
- Malleable cast iron
- Nodular cast iron

Grey cast iron

This is widely used for the casting of machinery parts and can be machined easily.

Machine bases, tables, slideways are made of cast iron because it is dimensionally stable after a period of aging.

Because of its graphite content, cast iron provides an excellent bearing and sliding surface.

The melting point is lower than that of steel and as grey cast iron possesses good fluidity, intricate casting can be made.

Grey cast iron is widely used for machine tools because of its ability to reduce vibration and minimize tool chatter.

Grey cast iron, when not alloyed, is quite brittle and has relatively low tensile strength. Due to this reason it is not used for making components subjected to high stress or impact loads.

Grey cast iron is often alloyed with nickel, chromium, vanadium or copper to make it tough.

Grey cast iron is weldable but the base metal needs pre-heating.

White cast iron

This is very hard and is very difficult to machine, and for this reason, it is used in components which should be abrasion-resistant.

White cast iron is produced by lowering the silicon content and by rapid cooling. When cooled in this manner, it is called chilled cast iron.

White cast iron cannot be welded.

Malleable cast iron

Malleable cast iron has increased ductility, tensile strength and toughness when compared with grey cast iron.

Malleable cast iron is produced from white cast iron by a prolonged heat-treatment process lasting for about 30 hours.

Nodular cast iron

This is very similar to malleable cast iron. But this is produced without any heat treatment. Nodular cast iron is also known as:

Nodular iron - ductile iron - spheroidal graphite iron

This has good machinability, castability, resistance to wear, low melting point and hardness.

Malleable and nodular castings are used for machine parts where there is a higher tensile stress and moderate impact loading. These castings are less expensive and are an alternative to steel casting.

Necessity of Interchangeability in engineering field

Objectives: At the end of this lesson you shall be able to

- state the advantages and disadvantages of mass production
- outline the meaning of the term, 'interchangeability'
- state the necessity for the limit system
- name the different standards of system of limits and fits.

Mass production

Mass production means production of a unit, component or part in large numbers.

Advantages of mass production

- Time for the manufacture of components is reduced.
- The cost of a piece is reduced.
- Spare parts can be quickly made available.

Disadvantages of mass production

- Special purpose machines are necessary.
- Jigs and fixtures are needed.
- Gauges are to be used instead of conventional precision instruments.
- Initial expenditure will be very high.

Selective assembly

The figures illustrate the difference between a selective assembly and a non-selective assembly. It will be seen in (Fig 1) that each nut fits only one bolt. Such an assembly is slow and costly, and maintenance is difficult because spares must be individually manufactured.

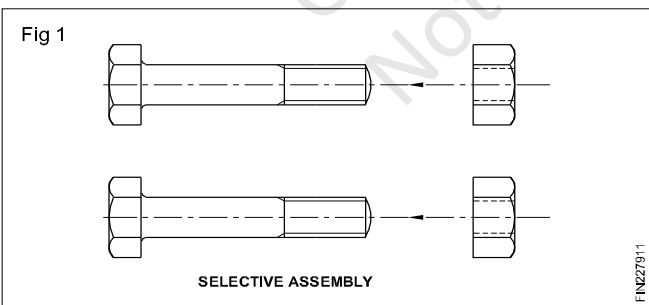

Non-selective assembly

Any nut fits any bolt of the same size and thread type. Such an assembly is rapid, and costs are reduced. Maintenance is simpler because spares are easily available. (Fig 2)

Non-selective assembly provides interchangeability between the components.

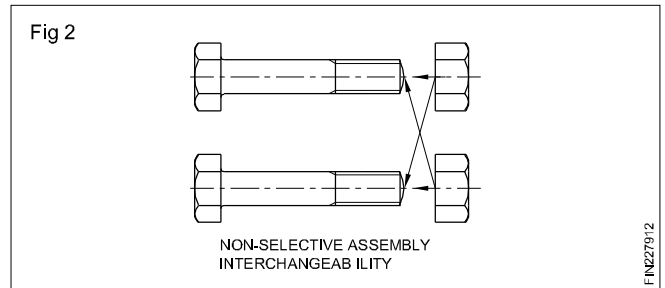

In modern engineering production, i.e. mass production, there is no room for selective assembly. However, under some special circumstances, selective assembly is still justified.

Interchangeability

When components are mass-produced, unless they are interchangeable, the purpose of mass production is not fulfilled. By interchangeability, we mean that identical components, manufactured by different personnel under different environments, can be assembled and replaced without any further rectification during the assembly stage, without affecting the functioning of the component when assembled.

Necessity of the limit system

If components are to be interchangeable, they need to be manufactured to the same size which is not possible, when they are mass-produced. Hence, it becomes necessary to permit the operator to deviate by a small margin from the exact size which he is not able to maintain for all the components. At the same time, the deviated size should not affect the quality of the assembly. This sort of dimensioning is known as limit dimensioning.

A system of limits is to be followed as a standard for the limit dimensioning of components.

Various standard systems of limits and fits are followed by different countries based on the ISO (International Standards Organisation) specifications.

The system of limits and fits followed in our country is stipulated by the BIS. (Bureau of Indian Standards)

Other systems of limits and fits

- International Standards Organisation (ISO)
- British Standard System (BSS)
- German Standard (DIN)

The indian standard system of limits & fits - terminology

Objectives: At the end of this lesson you shall be able to

- state the terms under the BIS system of limits and fits
- define each term under the BIS system of limits and fits.

Size

It is a number expressed in a particular unit in the measurement of length.

Basic size

It is the size based on which the dimensional deviations are given. (Fig 1)

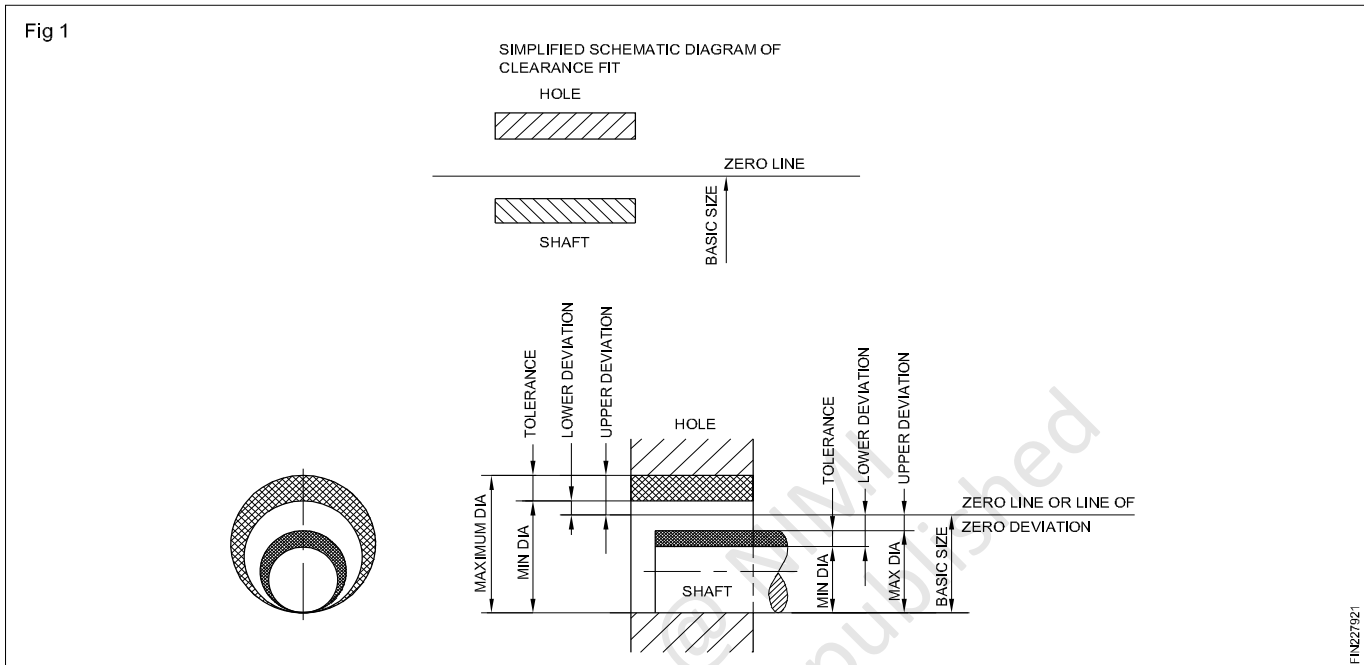

Actual size

It is the size of the component by actual measurement after it is manufactured. It should lie between the two limits of size if the component is to be accepted.

Limits of size

These are the extreme permissible sizes within which the operator is expected to make the component. (Fig 2) (Maximum and minimum limits)

Maximum limit of size

It is the greater of the two limit sizes. (Fig 2) (Table 1)

Minimum limit of size

It is the smaller of the two limits of size. (Fig 2) (Table 1)

Hole

In the BIS system of limits & fits, all internal features of a component including those which are not cylindrical are designated as 'hole'. (Fig 3)

Shaft

In the BIS system of limits & fits, all external features of a component including those which are not cylindrical are designated as shaft. (Fig 3)

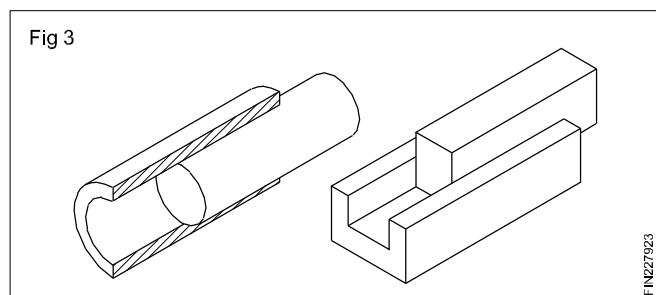
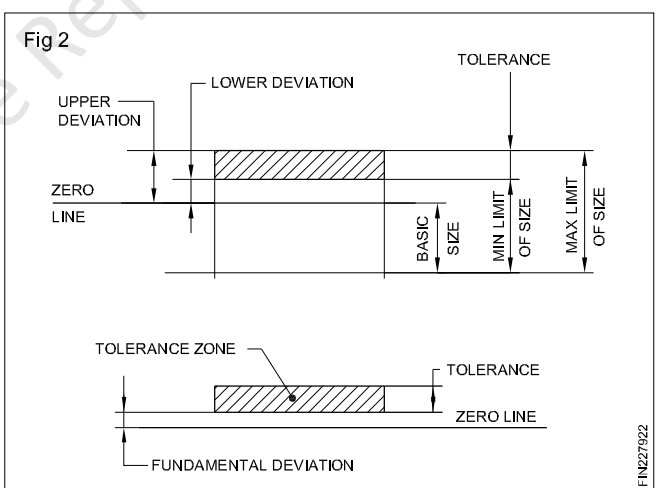

TABLE 1 (Examples)

SL. NO.	SIZE OF COMPONENT	UPPER DEVIATION	LOWER DEVIATION	MAX-LIMIT OF SIZE	MIN-LIMIT OF SIZE
1	+ .008 20 - .005	+ 0.008	- 0.005	20.008	19.995
2	+ .028 20 + .007	+ 0.028	+ 0.007	20.028	20.007
3	- .012 20 - .021	- 0.012	- 0.021	19.988	19.979

Deviation

It is the algebraic difference between a size, to its corresponding basic size. It may be positive, negative or zero. (Fig 2)

Upper deviation

It is the algebraic difference between the maximum limit of size and its corresponding basic size. (Fig 2) (Table 1)

Lower deviation

It is the algebraic difference between the minimum limit of size and its corresponding basic size. (Fig 2) (Table 1)

Upper deviation is the deviation which gives the maximum limit of size. Lower deviation is the deviation which gives the minimum limit of size.

Actual deviation

It is the algebraic difference between the actual size and its corresponding basic size. (Fig 2)

Tolerance

It is the difference between the maximum limit of size and the minimum limit of size. It is always positive and is expressed only as a number without a sign. (Fig 2)

Zero line

In graphical representation of the above terms, the zero line represents the basic size. This line is also called as the line of zero deviation. (Figs 1 and 2)

Fundamental deviation

There are 25 fundamental deviations in the BIS system represented by letter symbols (capital letters for holes and small letters for shafts), i.e for holes - ABCD....Z excluding I, L, O, Q & W. (Fig 4)

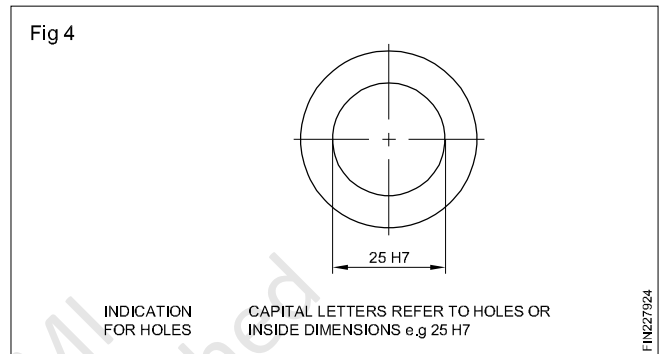

In addition to the above, four sets of letters JS, ZA, ZB & ZC are included. For fine mechanisms CD, EF and FG are added. (Ref.IS:919 Part II - 1979)

For shafts, the same 25 letter symbols but in small letters are used. (Fig 5)

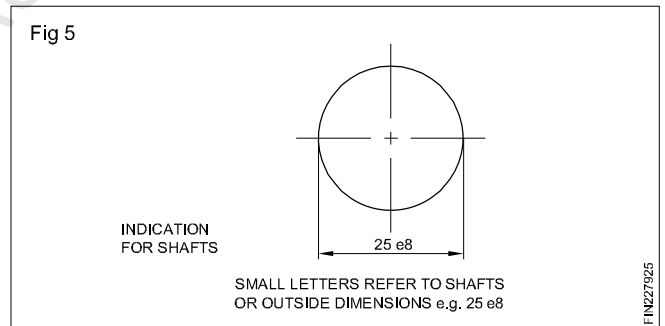

The position of tolerance zone with respect to the zero line is shown in Figs 6 and 7.

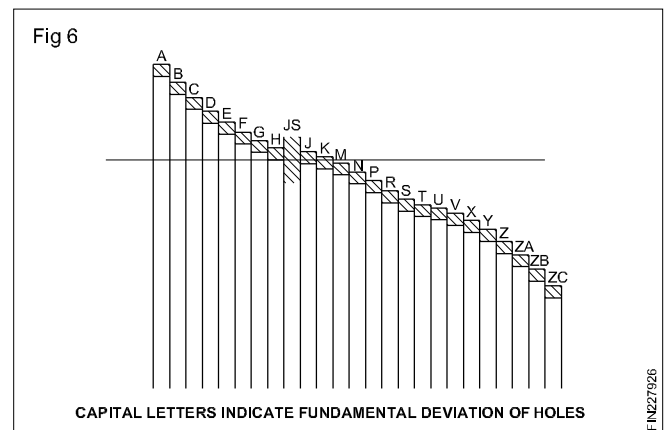

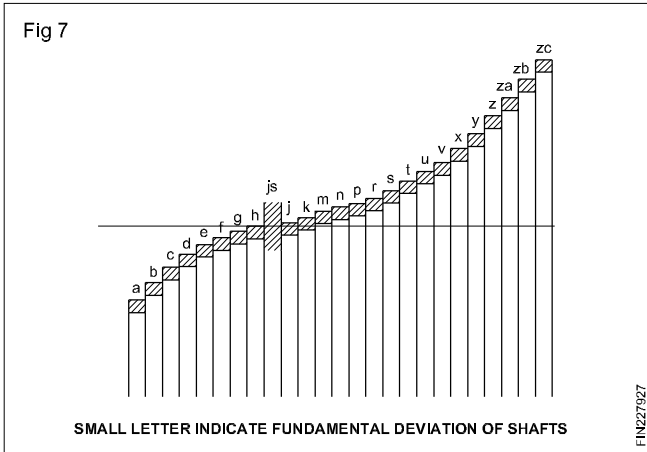

The fundamental deviations are for achieving the different classes of fits. (Figs 8 and 9)

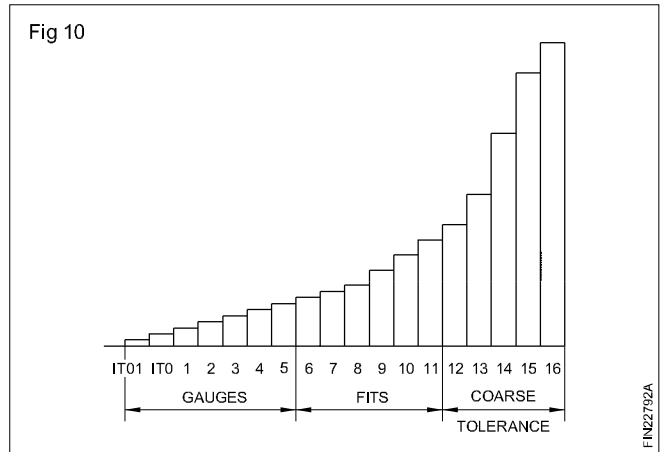

The grade of tolerance refers to the accuracy of manufacture.

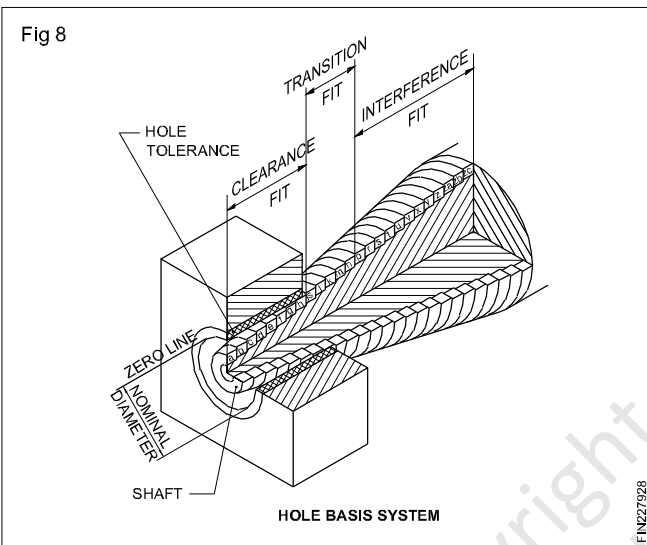

In a standard chart, the upper and lower deviations for each combination of fundamental deviation and fundamental tolerance are indicated for sizes ranging up to 500 mm. (Refer to IS 919)

Toleranced size

This includes the basic size, the fundamental deviation and the grade of tolerance.

Example

25 H7 - toleranced size of a hole whose basic size is 25. The fundamental deviation is represented by the letter symbol H and the grade of tolerance is represented by the number symbol 7. (Fig 11)

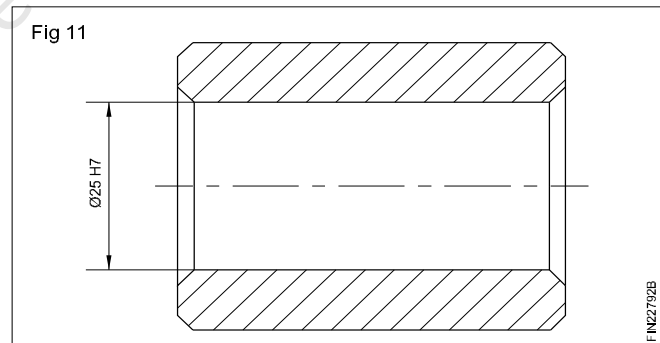
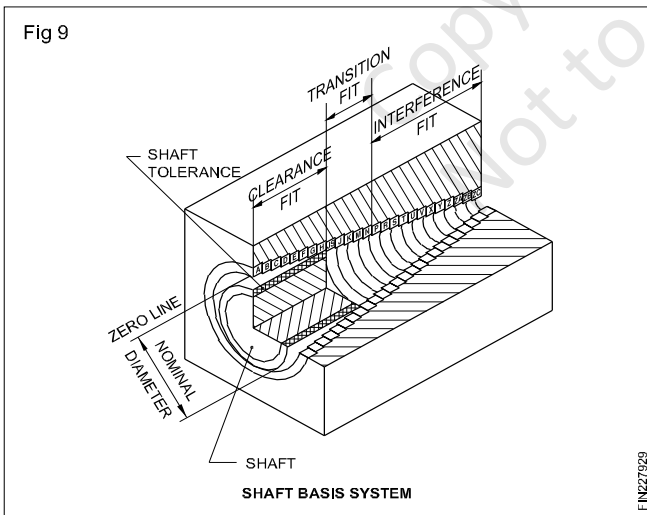

25 e8 - is the toleranced size of a shaft whose basic size is 25. The fundamental deviation is represented by the letter symbol e and the grade of tolerance is represented by the number 8. (Fig 12)

Fundamental tolerance

This is also called as 'grade of tolerance'. In the Indian Standard System, there are 18 grades of tolerances represented by number symbols, both for hole and shaft, denoted as IT01, IT0, IT1....to IT16. (Fig 10) A high number gives a large tolerance zone.

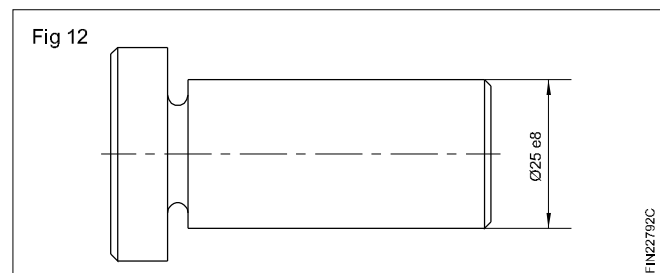

A very wide range of selection can be made by the combination of the 25 fundamental deviations and 18 grades of tolerances.

Example

In figure 13, a hole is shown as 25 ± 0.2 which means that 25 mm is the basic dimension and ± 0.2 is the deviation.

As pointed out earlier, the permissible variation from the basic dimension is called 'DEVIATION'.

The deviation is mostly given on the drawing with the dimensions.

In the example 25 ± 0.2 , ± 0.2 is the deviation of the hole of 25 mm diameter. (Fig 13) This means that the hole is of acceptable size if its dimension is between

$$25 + 0.2 = 25.2 \text{ mm}$$

$$\text{or } 25 - 0.2 = 24.8 \text{ mm.}$$

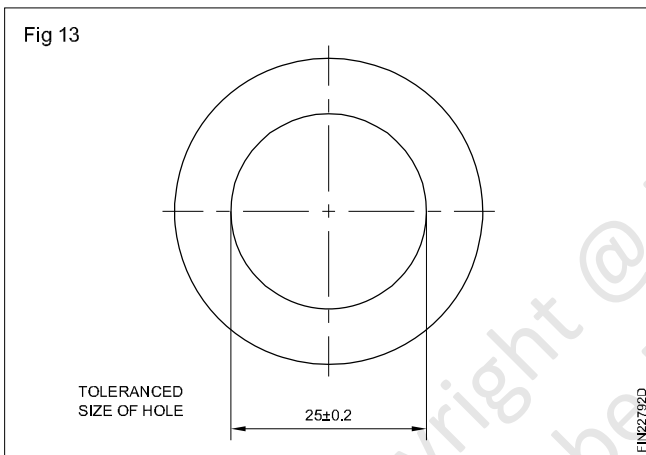

25.2 mm is known as the maximum limit. (Fig 14)

24.8 mm is known as the minimum limit. (Fig 15)

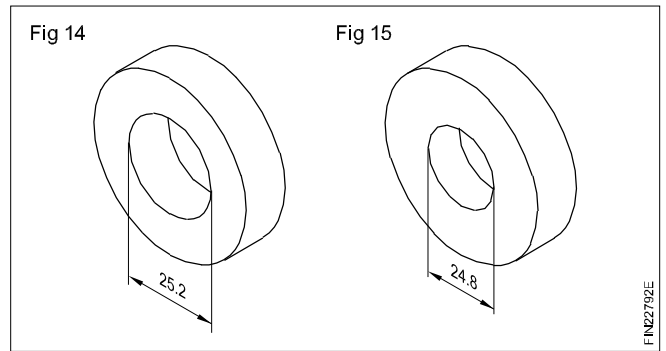

The difference between the maximum and minimum limits is the TOLERANCE. Tolerance here is 0.4 mm. (Fig 16)

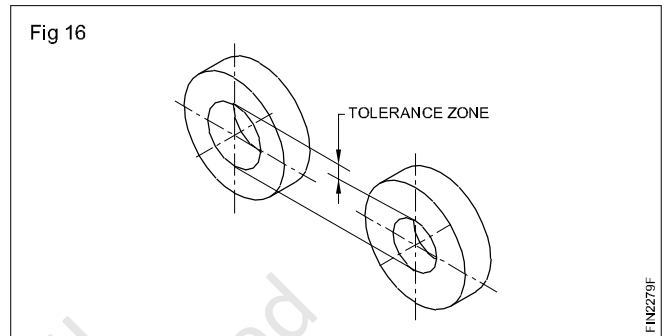

All dimensions of the hole within the tolerance zone are of acceptable size as in Fig 17.

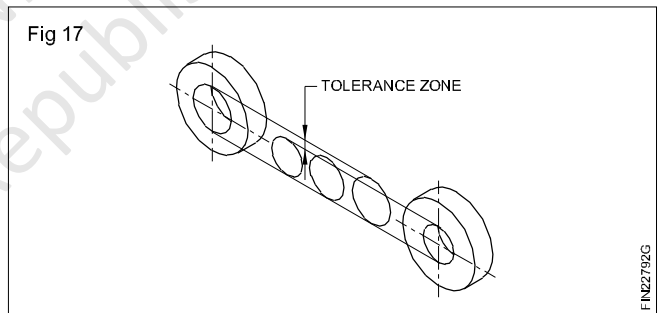

As per IS 696, while dimensioning the components as a drawing convention, the deviations are expressed as tolerances.

Fits and their classification as per the Indian Standard

Objectives: At the end of this lesson you shall be able to

- define 'Fit' as per the Indian Standard
- list out the terms used in limits and fits as per the Indian Standard
- state examples for each class of fit
- interpret the graphical representation of different classes of fits.

Fit

It is the relationship that exists between two mating parts, a hole and a shaft, with respect to their dimensional differences before assembly.

Expression of a fit

A fit is expressed by writing the basic size of the fit first, (the basic size which is common to both the hole and the

shaft,) followed by the symbol for the hole, and by the symbol for the shaft.

Example

$$30 \text{ H7/g6 or } 30 \text{ H7 - g6 or } 30 \frac{\text{H7}}{\text{g6}}$$

Clearance

In a fit the clearance is the difference between the size of the hole and the size of the shaft which is always positive.

Clearance fit

It is a fit which always provides clearance. Here the tolerance zone of the hole will be above the tolerance zone of the shaft. (Fig 1)

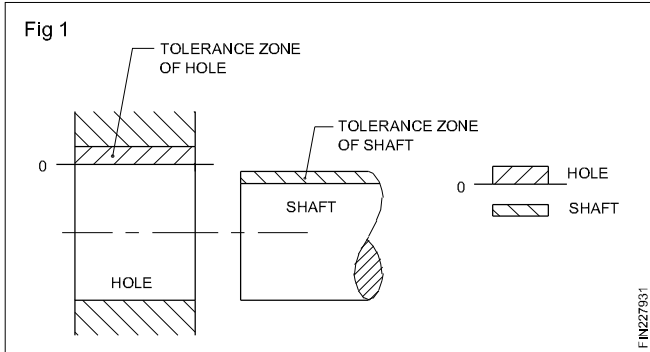

Example 20 H7/g6

With the fit given, we can find the deviations from the chart.

For a hole 20 H7 we find in the table + 21.

These numbers indicate the deviations in microns.

(1 micrometre = 0.001 mm)

The limits of the hole are $20 + 0.021 = 20.021$ mm and $20 + 0 = 20.000$ mm. (Fig.2)

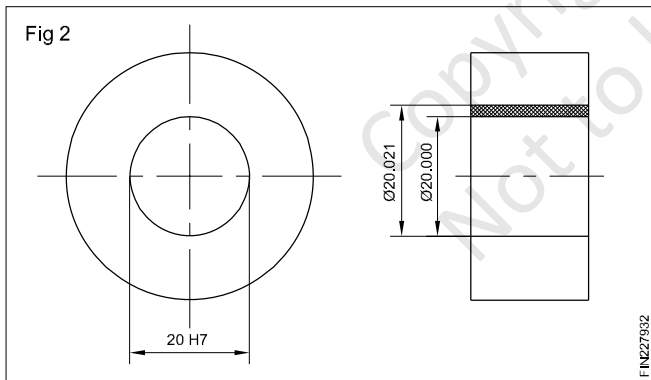

For a shaft 20 g6 we find in the table

- 7
- 20.

So the limits of the shaft are

$$20 - 0.007 = 19.993 \text{ mm}$$

and $20 - 0.020 = 19.980$ mm. (Fig .3)

Maximum clearance

In a clearance fit or transition fit, it is the difference between the maximum hole and minimum shaft. (Fig 4)

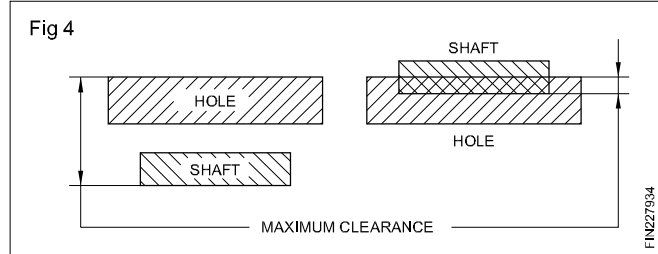
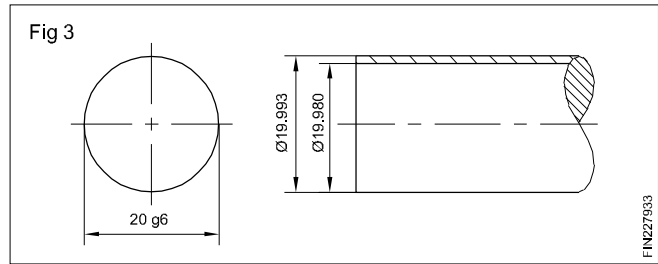

Minimum Clearance

In a clearance fit, it is the difference between the minimum hole and the maximum shaft. (Fig 5)

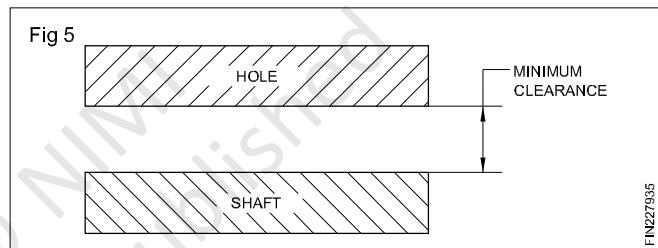

The minimum clearance is $20.000 - 19.993 = 0.007$ mm. (Fig 6)

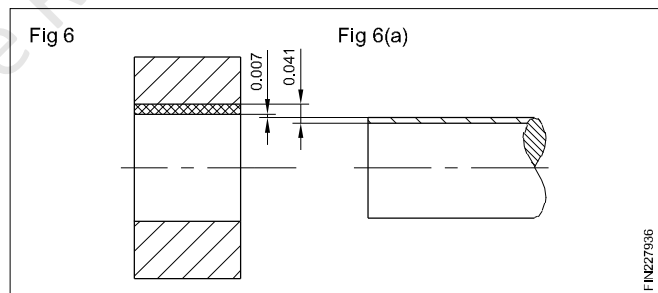

The maximum clearance is $20.021 - 19.980 = 0.041$ mm. (Fig 7)

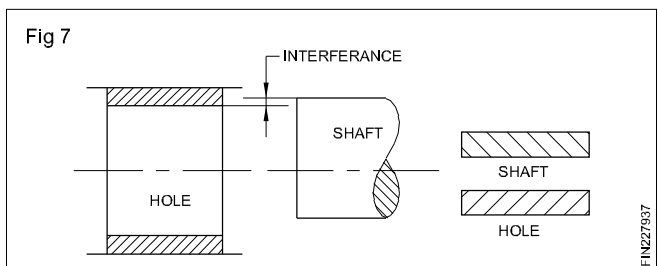

There is always a clearance between the hole and the shaft. This is the clearance fit.

Interference

It is the difference between the size of the hole and the shaft before assembly, and this is negative. In this case, the shaft is always larger than the hole size.

Interference Fit

It is a fit which always provides interference. Here the tolerance zone of the hole will be below the tolerance zone of the shaft. (Fig 8)

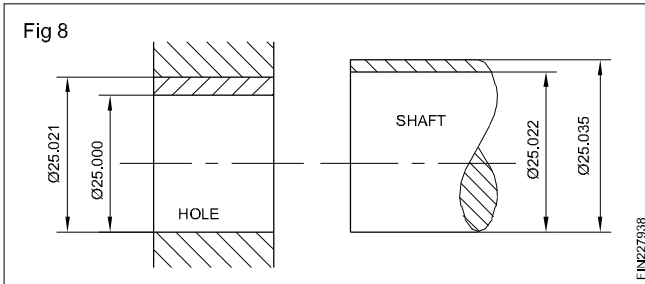

Example: Fit 25 H7/p6 (Fig 9)

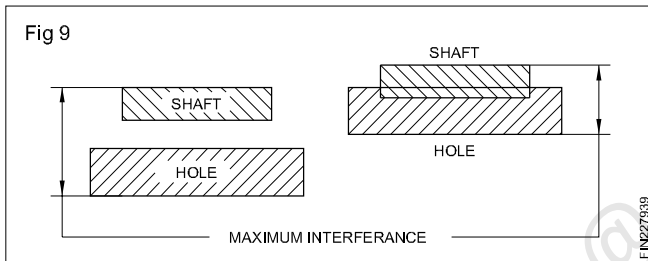

The limits of hole are 25.000 and 25.021 mm and the limits of the shaft 25.022 and 25.035 mm. The shaft is always bigger than the hole. This is an interference fit.

Maximum interference

In an interference fit or transition fit, it is the algebraic difference between the minimum hole and the maximum shaft. (Fig 10)

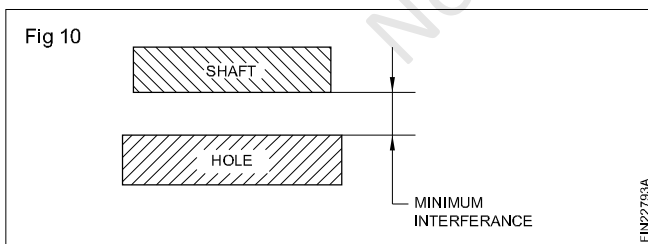

Minimum interference

In an interference fit, it is the algebraic difference between the maximum hole and the minimum shaft. (Fig 11)

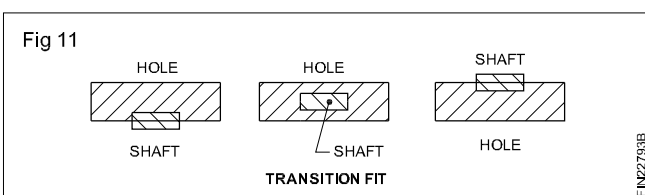

In the example shown in figure 9

The maximum interference is = $25.035 - 25.000$
= **0.035**

The minimum interference is = $25.022 - 25.021$
= **0.001**

Transition fit

It is a fit which may sometimes provide clearance, and sometimes interference. When this class of fit is represented graphically, the tolerance zones of the hole and shaft will overlap each other. (Fig 12)

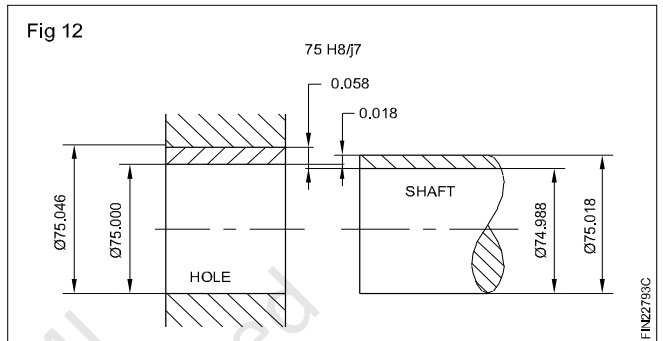

Example Fit 75 H8/j7 (Fig 13)

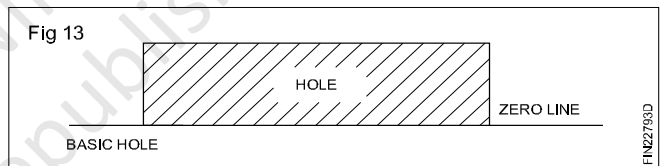

The limits of the hole are 75.000 and 75.046 mm and those of the shaft are 75.018 and 74.988 mm.

Maximum Clearance = $75.046 - 74.988 = 0.058$ mm.

If the hole is 75.000 and the shaft 75.018 mm, the shaft is 0.018 mm, bigger than the hole. This results in interference. This is a transition fit because it can result in a clearance fit or an interference fit.

Hole basis system

In a standard system of limits and fits, where the size of the hole is kept constant and the size of the shaft is varied to get the different class of fits, then it is known as the hole basis system.

The fundamental deviation symbol 'H' is chosen for the holes, when the hole basis system is followed. This is because the lower deviation of the hole 'H' is zero. It is known as 'basic hole'. (Fig 14)

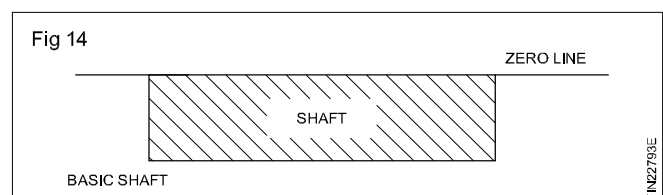

Shaft basis system

In a standard system of limits and fits, where the size of the shaft is kept constant and the variations are given to the hole for obtaining different class of fits, then it is known as shaft basis. The fundamental deviation symbol 'h' is chosen for the shaft when the shaft basis is followed. This is because the upper deviation of the shaft 'h' is zero. It is known as 'basic shaft'. (Fig 15)

The hole basis system is followed mostly. This is because, depending upon the class of fit, it will be always easier to alter the size of the shaft because it is external, but it is difficult to do minor alterations to a hole. Moreover the hole can be produced by using standard toolings.

The three classes of fits, both under hole basis and shaft basis, are illustrated in (Fig 15).

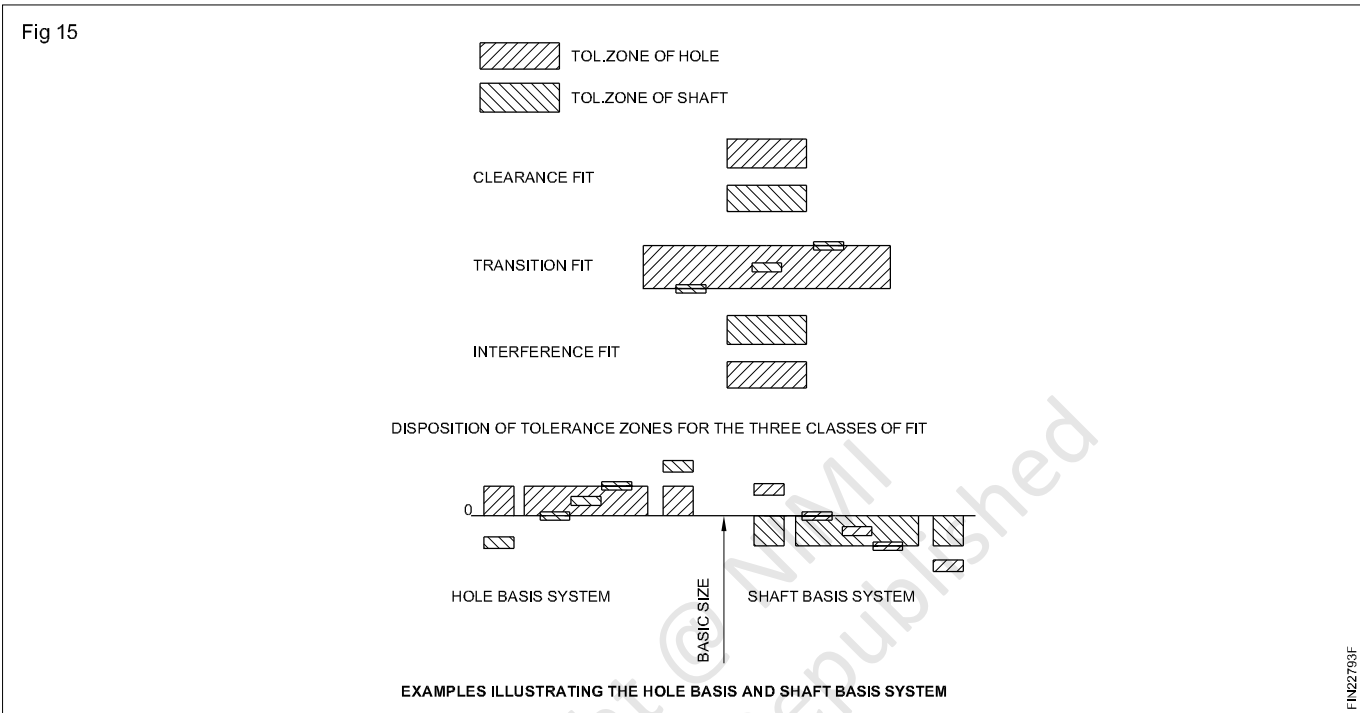

The BIS system of limits and fits- reading the standard chart

Objective: At the end of this lesson you shall be able to

- refer to the standard limit system chart and determine the limits of sizes.

The standard chart covers sizes upto 500 mm (I.S. 919 of 1963) for both holes and shafts. It specifies the upper and lower deviations for a certain range of sizes for all combinations of the 25 fundamental deviations, and 18 fundamental tolerances.

The upper deviation of the hole is denoted as ES and the lower deviation of the hole is denoted as EI. The upper deviation of the shaft is denoted as es and the lower deviation of the shaft is denoted as ei.

“ES is expanded as ECART SUPERIEUR and “EI” as ECART INFERIEUR.

Determining the limits from the chart

Note whether it is an internal measurement or an external measurement.

Note the basic size.

Note the combination of the fundamental deviation and the grade of tolerance.

Then refer to the chart and note the upper and lower deviations which are given in microns, with the sign. Accordingly add or subtract from the basic size and determine the limits of size of the components.

Example

30 H7 (Fig 1)

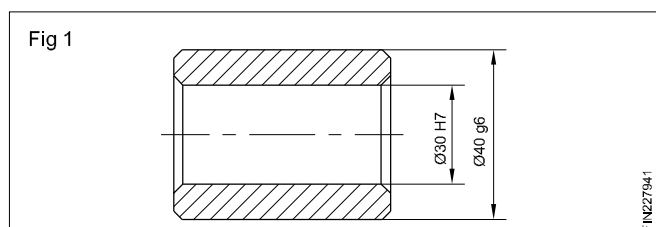

It is an internal measurement. So we must refer to the chart for 'holes'.

The basic size is 30 mm. So see the range 30 to 40.

Look for ES, and EI values in microns for H7 combination for 30 mm basic size.

It is given as

Therefore, the maximum limit of the hole is $30 + 0.025 = 30.025\text{mm}$.

The minimum limit of the hole is $30 + 0.000 = 30.000\text{mm}$.

Refer to the chart and note the values of 40 g6.

The table for tolerance zones and limits as per IS 2709 is attached.

British standard limits and fits BS 4500: 1969 International Tolerance Grades (IT)

The specific tolerance for a particular IT grade is calculated via the following formula:

T is the tolerance in micrometres [μm]

D is the geometric mean dimension in millimeters [mm]

$$T = 10^{0.2 \times (ITG - 1)} \cdot (0.45 \times \sqrt[3]{D} + 0.001 \times D)$$

ITG is the IT Grade, a positive integer.

NOMINAL (BASIC) SIZES (INCHES)		INTERNATIONAL TOLERANCE GRADES OVER UP TO INCL.									
OVER	UP TO INCL	IT4	IT5	IT6	IT7	IT8	IT9	IT10	IT11	IT12	IT13
0	0.12	0.12	0.15	0.25	0.4	0.6	1.0	1.6	2.5	4	6
0.12	0.24	0.15	0.20	0.3	0.5	0.7	1.2	1.8	3.0	5	7
0.24	0.40	0.15	0.25	0.4	0.6	0.9	1.4	2.2	3.5	6	9
0.40	0.71	0.2	0.3	0.4	0.7	1.0	1.6	2.8	4.0	7	10
0.71	1.19	0.25	0.4	0.5	0.8	1.2	2.0	3.5	5.0	8	12
1.19	1.97	0.3	0.4	0.6	1.0	1.6	2.5	4.0	6	10	16
1.97	3.15	0.3	0.5	0.7	1.2	1.8	3.0	4.5	7	12	18
3.15	4.73	0.4	0.6	0.9	1.4	2.2	3.5	5	9	14	22
4.73	7.09	0.5	0.7	1.0	1.6	2.5	4.0	6	10	16	25
7.09	9.85	0.6	0.8	1.2	1.8	2.8	4.5	7	12	18	28
9.85	12.41	0.6	0.9	1.2	2.0	3.0	5.0	8	12	20	30
12.41	15.75	0.7	1.0	1.4	2.2	3.5	6	9	14	22	35
15.75	19.69	0.8	1.0	1.63	2.5	4	6	10	16	25	40
19.69	30.09	0.9	1.2	2.0	3	5	8	12	20	30	50
30.09	41.49	1.0	1.6	2.5	4	6	10	16	25	40	60
41.49	56.19	1.2	2.0	3	5	8	12	20	30	50	80
56.19	76.39	1.6	2.5	4	6	10	16	25	40	60	100
76.39	100.9	2.0	3	5	8	12	20	30	50	80	125
100.9	131.9	2.5	4	6	10	16	25	40	60	100	160
131.9	171.9	3	5	8	12	20	30	50	80	125	200
171.9	200	4	6	10	16	25	40	60	100	160	250

Tolerances in Thousandths of an Inch (0.001)

Table 1 for Tolerance Zones & Limits (Dimensions in μm)

		N O M I N A L S I Z E R A N G E mm																																		
		s6	r6	p6	n6	k6	js6	h6	h7	h9	h11	g6	f7	e8	d9	c11	b11	a11	S7	R7	P7	N7	K7	JS7	H7	H8	H9	H11	G7	F8	E9	D10	C11	B11	A11	
From up to	1	+20	+16	+12	+10	+6	+3	0	0	0	0	-2	-6	-14	-20	-60	-140	-270	-14	-10	-6	-4	0	+5	+10	+14	+25	+60	+12	+20	+39	+60	+120	+200	+330	
	3	+14	+10	+6	+4	0	-3	-6	-10	-25	-60	-8	-16	-28	-45	-120	-200	-330	-24	-20	-16	-14	0	-5	0	0	0	0	+2	+6	+14	+20	+60	+140	+270	
Over up to	3	+27	+23	+20	+16	+9	+4	0	0	0	0	-4	-10	-20	-30	-70	-140	-270	-11	-11	-8	-4	+6	+12	+18	+30	+75	+16	+28	+50	+78	+145	+215	+345		
	6	+19	+15	+12	+8	+1	-4	-8	-12	-30	-75	-12	-22	-38	-60	-145	-215	-345	-17	-13	-20	-16	-9	-6	0	0	0	+4	+10	+20	+30	+70	+140	+270		
Over up to	10	+32	+28	+24	+19	+11	+4.5	0	0	0	0	-5	-13	-25	-40	-80	-150	-280	-17	-13	-9	-4	+5	+7.5	+15	+22	+36	+90	+20	+35	+61	+98	+170	+240	+370	
	18	+23	+19	+15	+10	+1	-4.5	-9	-15	-36	-90	-14	-28	-47	-76	-170	-240	-370	-32	-28	-24	-19	-10	-7.5	0	0	0	+5	+13	+25	+40	+80	+150	+280		
Over up to	10	+39	+34	+29	+23	+12	+5.5	0	0	0	0	-6	-16	-32	-50	-95	-150	-290	-21	-16	-11	-5	+6	+9	+18	+27	+43	+110	+24	+43	+75	+120	+205	+260	+400	
Over up to	14	+28	+23	+18	+12	+1	-5.5	-11	-18	-43	-110	-17	-34	-59	-93	-205	-260	-400	-39	-34	-29	-23	-12	-9	0	0	0	+6	+16	+32	+50	+95	+150	+290		
Over up to	18	+48	+41	+35	+28	+15	+2	-6.5	-21	-52	-130	-20	-41	-73	-117	-240	-290	-430	-48	-41	-35	-28	-15	-10.5	0	0	0	+7	+20	+40	+65	+110	+160	+300		
Over up to	24	+59	+50	+42	+33	+17	+8	-8	-25	-62	-160	-25	-50	-89	-142	-300	-340	-480	-59	-50	-42	-33	-18	-12.5	0	0	0	+9	+25	+50	+80	+130	+180	+320		
Over up to	30	+72	+60	+51	+39	+21	+9.5	0	-30	-74	-190	-34	-60	-106	-174	-330	-380	-530	-62	-50	-42	-33	-18	-12.5	0	0	0	+34	+64	+112	+180	+280	+330	+470		
Over up to	40	+83	+73	+59	+45	+25	+11	0	-36	-87	-220	-44	-72	-126	-207	-400	-460	-630	-76	-60	-51	-42	-25	-17.5	0	0	0	+40	+76	+134	+220	+340	+440	+600		
Over up to	50	+93	+81	+67	+51	+29	+13	-1	-43	-100	-250	-52	-83	-148	-245	-450	-510	-710	-88	-72	-62	-51	-33	-20	-15	0	0	+10	+30	+60	+100	+150	+200	+260	+330	+430
Over up to	65	+101	+86	+70	+53	+31	+14.5	0	-46	-115	-280	-60	-85	-145	-245	-480	-540	-770	-93	-78	-68	-58	-40	-25	-17.5	0	0	+12	+36	+72	+120	+180	+240	+310	+410	
Over up to	80	+108	+93	+76	+59	+34	+16.5	-2	-50	-130	-300	-66	-93	-155	-260	-500	-560	-800	-93	-83	-74	-64	-45	-28	-19.5	0	0	+12	+36	+72	+120	+180	+240	+310	+410	
Over up to	100	+117	+98	+81	+61	+37	+18.5	0	-56	-140	-330	-72	-100	-170	-285	-530	-590	-830	-93	-83	-74	-64	-45	-28	-19.5	0	0	+12	+36	+72	+120	+180	+240	+310	+410	
Over up to	120	+122	+106	+89	+66	+40	+20.5	0	-56	-140	-330	-72	-100	-170	-285	-530	-590	-830	-93	-83	-74	-64	-45	-28	-19.5	0	0	+12	+36	+72	+120	+180	+240	+310	+410	
Over up to	140	+125	+109	+90	+68	+43	+22.5	0	-56	-140	-330	-72	-100	-170	-285	-530	-590	-830	-93	-83	-74	-64	-45	-28	-19.5	0	0	+12	+36	+72	+120	+180	+240	+310	+410	
Over up to	160	+133	+113	+93	+70	+47	+25.5	0	-56	-140	-330	-72	-100	-170	-285	-530	-590	-830	-93	-83	-74	-64	-45	-28	-19.5	0	0	+12	+36	+72	+120	+180	+240	+310	+410	
Over up to	180	+138	+118	+98	+75	+50	+28.5	0	-56	-140	-330	-72	-100	-170	-285	-530	-590	-830	-93	-83	-74	-64	-45	-28	-19.5	0	0	+12	+36	+72	+120	+180	+240	+310	+410	
Over up to	200	+144	+124	+104	+81	+56	+31.5	0	-56	-140	-330	-72	-100	-170	-285	-530	-590	-830	-93	-83	-74	-64	-45	-28	-19.5	0	0	+12	+36	+72	+120	+180	+240	+310	+410	
Over up to	225	+159	+139	+119	+96	+61	+36.5	0	-56	-140	-330	-72	-100	-170	-285	-530	-590	-830	-93	-83	-74	-64	-45	-28	-19.5	0	0	+12	+36	+72	+120	+180	+240	+310	+410	
Over up to	250	+169	+149	+129	+106	+71	+41.5	0	-56	-140	-330	-72	-100	-170	-285	-530	-590	-830	-93	-83	-74	-64	-45	-28	-19.5	0	0	+12	+36	+72	+120	+180	+240	+310	+410	
Over up to	280	+184	+164	+144	+121	+86	+46.5	0	-56	-140	-330	-72	-100	-170	-285	-530	-590	-830	-93	-83	-74	-64	-45	-28	-19.5	0	0	+12	+36	+72	+120	+180	+240	+310	+410	
Over up to	315	+208	+188	+168	+145	+100	+51.5	0	-56	-140	-330	-72	-100	-170	-285	-530	-590	-830	-93	-83	-74	-64	-45	-28	-19.5	0	0	+12	+36	+72	+120	+180	+240	+310	+410	
Over up to	355	+244	+224	+204	+181	+125	+57.5	0	-56	-140	-330	-72	-100	-170	-285	-530	-590	-830	-93	-83	-74	-64	-45	-28	-19.5	0	0	+12	+36	+72	+120	+180	+240	+310	+410	
Over up to	400	+272	+252	+232	+209	+143	+63.5	0	-56	-140	-330	-72	-100	-170	-285	-530	-590	-830	-93	-83	-74	-64	-45	-28	-19.5	0	0	+12	+36	+72	+120	+180	+240	+310	+410	
Over up to	450	+323	+303	+283	+260	+175	+70.5	0	-56	-140	-330	-72	-100	-170	-285	-530	-590	-830	-93	-83	-74	-64	-45	-28	-19.5	0	0	+12	+36	+72	+120	+180	+240	+310	+410	
Over up to	500	+352	+332	+312	+289	+204	+77.5	0	-56	-140	-330	-72	-100	-170	-285	-530	-590	-830	-93	-83	-74	-64	-45	-28	-19.5	0	0	+12	+36	+72	+120	+180	+240	+310	+410	

Vernier height gauge

Objectives: At the end of this lesson you will be able to

- identify and name the parts of a vernier height gauge
- state the constructional features of a vernier height gauge
- state the functional features of a vernier height gauge
- identify the various applications of the vernier height gauge in engineering.

Parts of a vernier height gauge (Fig 1)

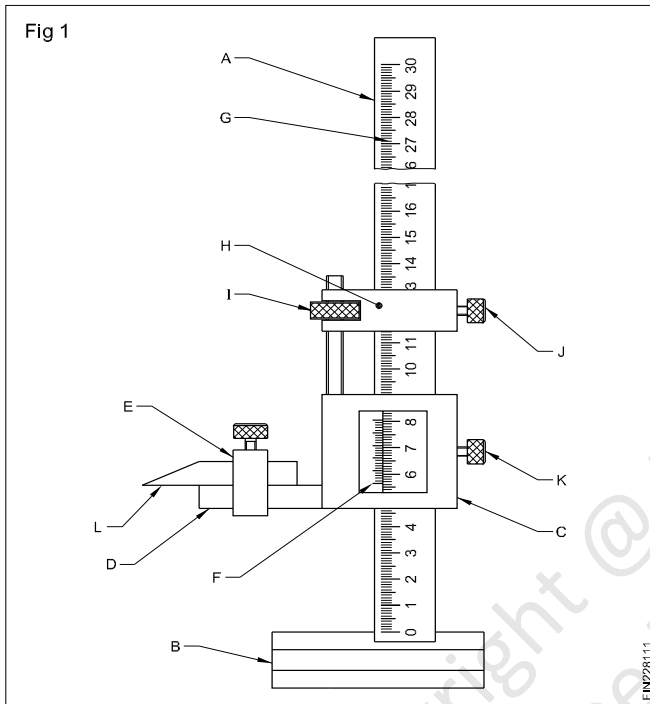

- A Beam
- B Base
- C Main slide
- D Jaw
- E Jaw clamp
- F Vernier scale
- G Main scale
- H Finer adjusting slide
- I Finer adjusting nut
- J&K Locking screws
- L Scriber blade

Constructional features of a vernier height gauge:

The construction of a vernier height gauge is similar to that of the vernier caliper that it is vertical with a rigid base. It is graduated on the same vernier principle which is applied to the vernier caliper.

The beam is graduated with the main scale in mm as well as in inches. The main slide carries a jaw upon which various attachments may be clamped. The jaw is an integral part of the main slide.

The vernier scale is attached to the main slide which has been graduated, to read metric dimensions as well as the inch dimensions. The main slide is attached with the finer adjusting slide. The movable jaw is most widely used with the chisel pointed scriber blade for accurate marking out as well as for checking the height, steps etc. Care should be taken to allow for the thickness of the jaw depending on whether the attachment is clamped on the top or under the jaw for this purpose.

The thickness of the jaw is marked on the instrument. As like in a vernier caliper, the least count of this instrument is also 0.02 mm. An offset scriber is also used on the movable jaw when it is required to take measurement from the lower planes. (Fig 2) The complete sliding attachment along with the jaw can be arrested on the beam to the desired height with the help of the lock screws. The vernier height gauges are available in ranges of capacities reading from zero to 1000 mm.

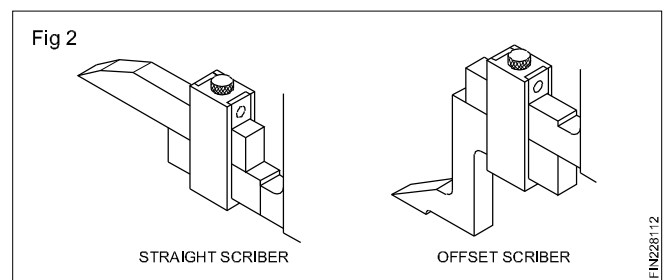

Functional features of the vernier height gauge:

Vernier height gauges are used in conjunction with the surface plate. In order to move the main slide, both the locking screws of the slide and the finer adjusting slide have to be loosened. The main slide along with the chisel pointed scriber has to be set by hand, for an approximate height as required.

The finer adjusting slide has to be locked in position, for an approximate height as required. To get an exact markable height, the finer adjustments have to be carried on the slider with the help of the adjusting nut. After obtaining the exact markable dimension, the main slide is also to be locked in position.

Modern vernier height gauges are designed on the screw rod principle. In these height gauges, the screw rod may be operated with the help of the thumb screw at the base. In order to have a quick setting of the main slide, it is designed with a quick releasing manual mechanism. With the help of this, it is possible to bring the slide to a desired approximate height without wastage of time. For all other purposes, these height gauges work as ordinary height gauges. In order to set the 'zero' graduation of the main scale for the initial reading.

Some vernier height gauges are equipped with a sliding main scale which may be set immediately for the initial reading. This minimises the possible errors in reading the various sizes in the same setting.

Another kind of modern vernier height gauge has a rack and pinion set up for operating the sliding unit. This is shown in Fig 3.

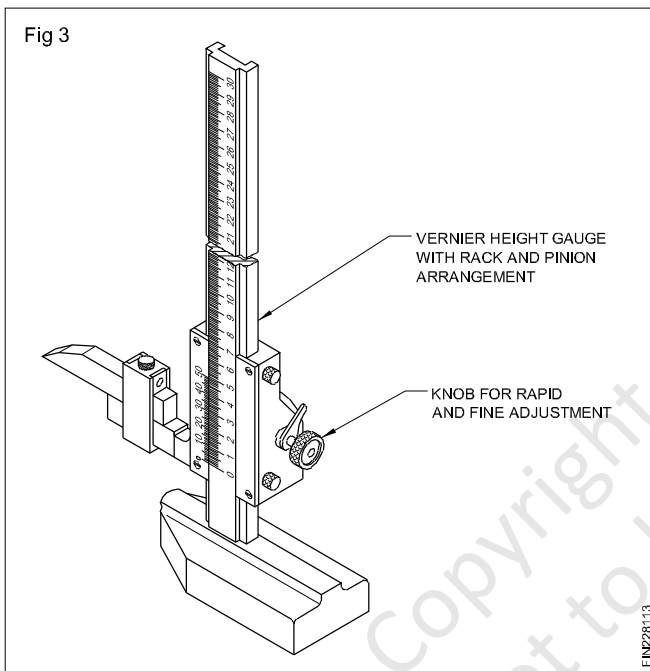

Various applications of a vernier height gauge: The vernier height gauge is mainly used for layout work. (Fig 4)

It is used for measuring the width of the slot and external dimension.

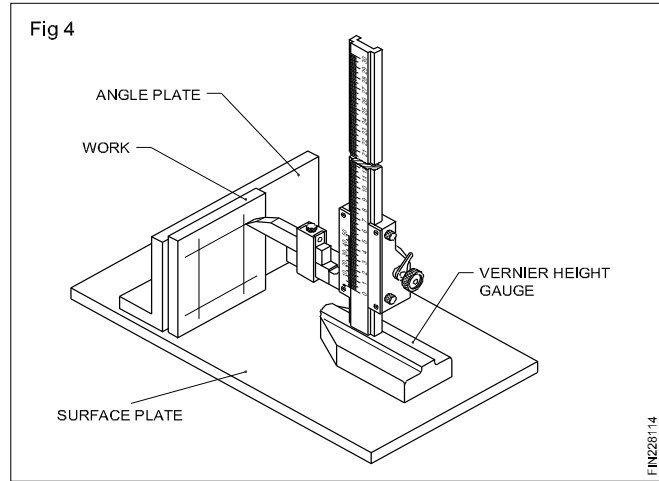

The vernier height gauge is used with the dial indicator to check hole location, pitch dimensions, concentricity and eccentricity.

It is also used for measuring depth, with a depth attachment.

It is used to measure sizes from the lower plane with the help of an offset scriber.

Vernier height gauge is made of invarsteel/ stainless steel.

Care and maintenance of vernier height gauge

- After using the vernier height gauge, you should wipe the measuring faces with a clean, dry cloth.
- After use, it is important that you should check the beam of your vernier height gauge for any unwanted residue that may affect the sliding motion of the vernier scale.
- Apply a small drop of oil to the beam of the height gauge, clean it with a cloth and slide the vernier scale backward and forward a couple of times.
- Vernier height gauge should be stored in a well ventilated humid free environment.
- Most height gauge come with a protective case to keep them safe when not in use.
- You should regularly check the calibration of your height gauge, to make sure that it is working correctly.

Wrought iron and plain carbon steels

Objectives: At the end of this lesson you shall be able to

- state the manufacturing process of wrought iron
- state the properties and uses of wrought iron.

Wrought iron is the purest form of iron. The analysis of wrought iron shows as much as 99.9% of iron. (Fig 1)

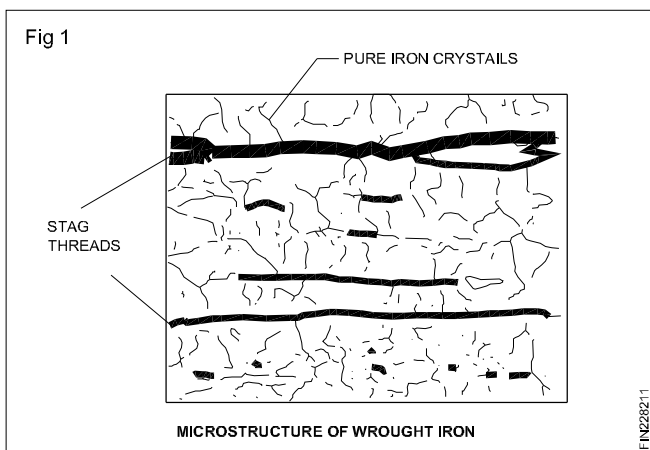

When heated, wrought iron does not melt, but only becomes pasty and in this form it can be forged to any shape.

Modern methods used to produce wrought iron in large quantities are the:

- Puddling process
- Aston or Byers process.

Puddling process

Wrought iron is manufactured by refining pig-iron.

By refining pig-iron silicon is removed completely, a greater amount of phosphorus is removed, and graphite is converted to combined carbon.

The above process is carried out in a puddling furnace.

Puddling furnace

This furnace is a coal-fired reverberatory furnace. (Fig 2)

The term reverberatory is applied because the charge is not in actual contact with the fire, but receives its heat by reflection from the dome shaped furnace roof.

The product obtained is taken out from the furnace in the form of balls (or blooms) having a mass of about 50 kgs.

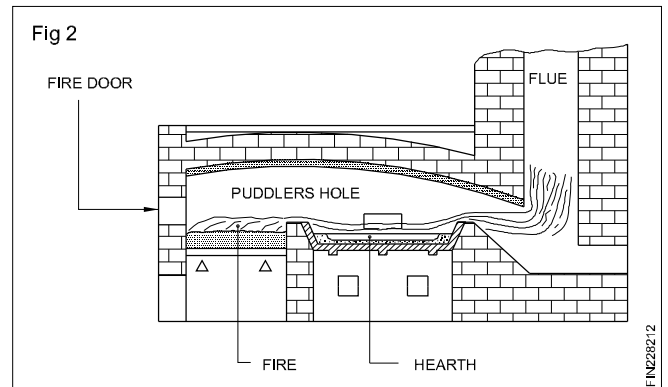

The hot metal is then passed through grooved rollers which convert blooms into bars called Muck bars or Puddle bars.

These bars are cut into short lengths, fastened together in piles, reheated to welding temperatures and again rolled into bars.

Aston process

In this process molten pig-iron and steel scrap are refined in a Bessemer converter.

The refined molten metal is poured into an open hearth furnace in the iron silicate stage. This removes most of the carbon.

The slag cools the molten metal to a pasty mass which is later squeezed in a hydraulic press to remove most of the slag. Rectangular blocks known as blooms are formed from this mass.

The hot bloom is immediately passed through rolling mills to produce products of wrought iron of different shapes and sizes.

COMPOSITION OF WROUGHT IRON

Carbon	-	0.02 to 0.03%
Silicon	-	0.1 to 0.2%
Manganese	-	0.02 to 0.1%
Sulphur	-	0.02 to 0.04%
Phosphorous	-	0.05 to 0.2%
Iron forms of the rest of the content.		

Properties and uses of Wrought Iron

Properties	Uses
Malleable and ductile. It can neither be hardened nor tempered.	Architectural works.
Tough, shock-resistant fibrous structure; easy for forge welding. Ultimate tensile strength of about 350 newtons per sq. mm.	Crane hooks, chain links, bolts and nuts & railway couplings.
No effect in salt water.	Marine works.
Will not retain the magnetism.	Temporary magnets. Core of dynamos.
Corrosion resistant.	Agricultural equipment.
Easy to forge - wide temperaturerange 850°C to 1350°C.	Pipes, flanges etc.

Steel (plain carbon steel)

Objective: At the end of this lesson you shall be able to

- state the composition and properties of plain carbon steel.

Steel is fundamentally an alloy of iron and carbon, with the carbon content varying up to 1.5%. The carbon present is in a combined state.

Plain carbon steels are classified according to their carbon content.

Classification and content of Plain Carbon Steel is given in Table 1.

TABLE 1
Classification and content of Plain Carbon Steel

Name of the plain carbon steel	Percentage of Carbon	Properties and uses
Dead mild steel	0.1 to 0.125 %	Highly ductile. Used for making wire rods, thin sheets & solid drawn tubes.
Mild steel	0.15 to 0.3%	Relatively soft and ductile. Used for general workshop purposes, boiler plates, bridge work, structural sections and drop forgings.
Medium carbon	0.3 to 0.5%	Used for making axles, drop forgings, high tensile tubes, wires and agricultural tools.
- do -	0.5 to 0.7%	Harder, tougher and less ductile. Used for making springs, locomotive tyres, large forging dies, wire ropes, hammers and snaps for riveters.
High carbon steel	0.7 to 0.9%	Harder, less ductile and slightly less tough. Used for making springs, small forging dies, shear blades and wood chisels.
- do -	0.9 to 1.1%	Used for making cold chisels, press dies, punches, wood-working tools, axes, etc.
- do -	1.1% to 1.4%	Used for making hand files, drills, gauges, metal-cutting tools & razors.

Non-ferrous metals - copper

Objectives: At the end of this lesson you shall be able to

- name the commonly used copper alloys
- state the properties and uses of copper
- state the composition and uses of different types of brasses
- state the composition and uses of different types of bronze.

Metals without iron are called non-ferrous metals. Eg. Copper, Aluminium, Zinc, Lead and Tin.

Copper

This is extracted from its ores 'MALACHITE' which contains about 55% copper and 'PYRITES' which contains about 32% copper.

Properties

Reddish in colour. Copper is easily distinguishable because of its colour.

The structure when fractured is granular, but when forged or rolled it is fibrous.

It is very malleable and ductile and can be made into sheets or wires.

It is a conductor of electricity. Copper is extensively used as electrical cables and parts of electrical apparatus which conduct electric current. (Fig 1)

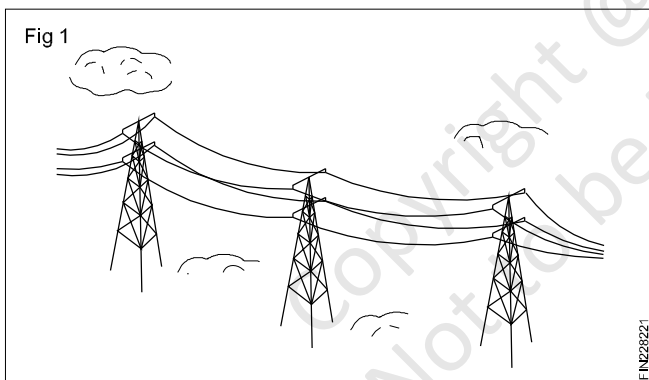

Copper is a good conductor of heat and also highly resistant to corrosion. For this reason it is used for boiler fire boxes, water heating apparatus, water pipes and vessels in brewery and chemical plants. Also used for making soldering iron.

The melting temperature of copper is 1083° C.

The tensile strength of copper can be increased by hammering or rolling.(Fig 2)

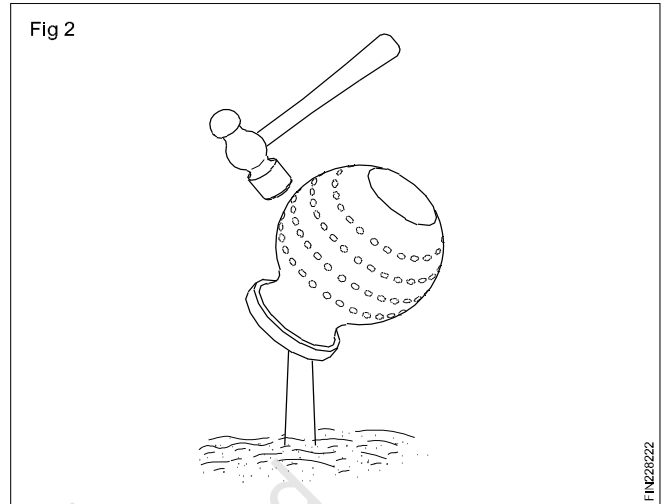

Copper alloys

Brass

It is an alloy of copper and zinc. For certain types of brass small quantities of tin or lead are added. The colour of brass depends on the percentage of the alloying elements. The colour is yellow or light yellow, or nearly white. It can be easily machined. Brass is also corrosion-resistant.

Brass is widely used for making motor car radiator core and water taps etc. It is also used in gas welding for hard soldering/brazing. The melting point of brass ranges from 880 to 930°C.

Brasses of different composition are made for various applications. The following table-1 gives the commonly used brass alloy compositions and their application.

Bronze

Bronze is basically an alloy of copper and tin. Sometimes zinc is also added for achieving certain special properties. Its colour ranges from red to yellow. The melting point of bronze is about 1005°C. It is harder than brass. It can be easily machined with sharp tools. The chip produced is granular. Special bronze alloys are used as brazing rods. Bronze of different compositions are available for various applications. Table-2 gives the type compositions and applications of different bronzes.

TABLE 1 - Composition of different types of Brass

Name	Composition (%)			Applications
	Copper	Zinc	Other elements	
Cartridge brass	70	30	-	Most ductile of the copper/zinc alloys. Widely used in sheet metal pressing for severe deep drawing operations. Originally developed for making cartridge cases, hence its name.
Standard brass	65	35	-	Cheaper than cartridge brass and less ductile. Suitable for most engineering processes.
Basic brass	63	37	-	The cheapest of the cold working brasses. It lacks ductility and is only capable of withstanding simple forming operations.
Muntz metal	60	40	-	Not suitable for cold working, but suitable for hot-working. Relatively cheap due to its high zinc content. It is widely used for extrusion and hot-stamping processes.
Free-cutting brass	58	39	3% lead	Not suitable for cold working but excellent for hot working and high speed machining of low strength components.
Admiralty brass	70	29	1% tin	This is virtually cartridge brass plus a little tin to prevent corrosion in the presence of salt water.
Naval brass	62	37	1% tin	This is virtually Muntz metal plus a little tin to prevent corrosion in the presence of salt water.
Gilding metal	95	5	-	Used for jewellery.

TABLE 2 - Composition of different types of bronze

Name	Composition (%)				Applications
	Copper	Zinc	Phosphorus	Tin	
Low tin bronze	96	-	0.1 to 0.25	3.9 to 3.75	This alloy can be severely cold-worked to harden it so that it can be used for springs where good elastic properties must be combined with corrosion resistance, fatigue-resistance and electrical conductivity. Eg. Contact blades
Drawn phosphor/bronze	94	-	0.1 to 0.5	5.9 to 5.5	This alloy is used for turned components requiring strength and corrosion resistance, such as valve spindles.
Cast phosphor/bronze	89.75 to 89.97		0.03 to 0.25	10	Usually cast into rods and tubes for making bearing bushes and worm wheels. It has excellent anti-friction properties.
Admiralty gun-metal	88	2	-	10	This alloy is suitable for sand casting where fine-grained, pressure-tight components such as pump and valve bodies are required.
Leaded gun-metal (free cutting)	85	5 (5%lead)	-	5	Also known as 'red brass' this alloy is used for the same purposes as standard, admiralty gun-metal. It is rather less strong but has improved toughness and machining properties.
Leaded (plastic) bronze	74	(24%lead)	-	2	This alloy is used for lightly loaded bearings where alignment is difficult. Due to its softness, bearings made from this alloy "bed in" easily.

Lead

Objectives: At the end of this lesson you shall be able to

- state the properties of lead
- state the various uses of lead
- state the uses of babbitt metal.

Lead is a very commonly used non-ferrous metal and has a variety of industrial applications.

Lead is produced from its ore 'GALENA'. Lead is a heavy metal that is silvery in colour when molten. It is soft and malleable and has good resistance to corrosion. It is a good insulator against nuclear radiation. Lead is resistant to many acids like sulphuric acid and hydrochloric acid.

It is used in car batteries, in the preparation of solders etc. It is also used in the preparation of paints. (Fig 1)

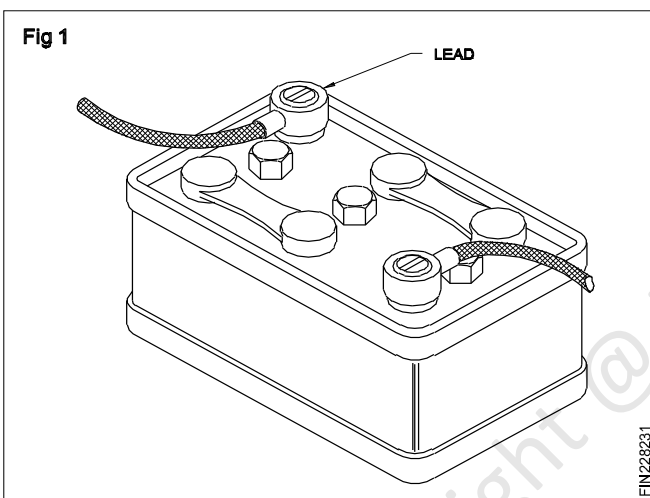

Lead Alloys

Babbitt metal

Babbitt metal is an alloy of lead, tin, copper and antimony. It is a soft, anti-friction alloy, often used as bearings.

An alloy of lead and tin is used as 'soft solder. (Fig 2)

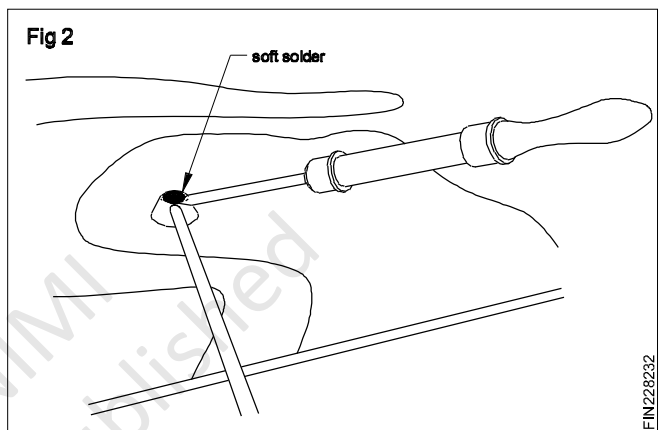

Zinc

Objectives: At the end of this lesson you shall be able to

- state the properties and uses of zinc
- state the uses of zinc alloys.

Zinc is a commonly used metal for coating on steel to prevent corrosion. Examples are steel buckets, galvanized roofing sheets, etc.

Zinc is obtained from the ore-calamine or blende.

Its melting point is 420° C.

It is brittle and softens on heating; it is also corrosion-resistant. Due to this reason it is used for battery containers and is coated on roofing sheets etc.

Galvanized iron sheets are coated with zinc.

Tin

Objectives: At the end of this lesson you shall be able to

- state the properties and uses of tin
- name the common tin alloys and state their uses.

Tin

Tin is produced from cassiterite or tinstone. It is silvery white in appearance, and the melting point is 231° C. It is soft and highly corrosion-resistant.

It is mainly used as a coating on steel sheets for the production of food containers. It is also used with other metals, to form alloys.

Example: Tin with copper to form bronze. Tin with lead to form solder. Tin with copper, lead and antimony to form Babbitt metal.

Aluminium

Objectives: At the end of this lesson you shall be able to

- state the properties and uses of aluminium
- name the commonly used aluminium alloys and their uses
- name the ores from which aluminium is produced.

Aluminium

Aluminium is a non-ferrous metal which is extracted from 'BAUXITE'. Aluminium is white or whitish grey in colour. It has a melting point of 660° C. Aluminium has high electrical and thermal conductivity. It is soft and ductile, and has

low tensile strength. Aluminium is very widely used in aircraft industry and fabrication work because of its lightness. Its application in the electrical industry is also on the increase. It is also very much in use in household heating appliances. Some typical aluminium alloys, their composition and applications are given in the table that follows.

ALUMINIUM ALLOYS - COMPOSITION - USES

Composition(%) (Only the percentage of alloying elements is shown. The remaining is aluminium.)						Category	Applications
Copper	Silicon	Iron	Manganese	Magnesium	Other elements		
0.1 max.	0.5 max.	0.7 max.	0.1 max.	-	-	Wrought. Not heat treatable.	Fabricated assemblies, Electrical conductors. Food and brewing, processing plants. Architectural decorations.
0.15 max.	0.6 max.	0.75 max.	1.0 max.	4.5 to 5.5	0.5 Chromium	Wrought. Not heat treatable.	High strength ship building and engineering products. Good corrosion resistance.
1.6	10.0	-	-	-	-	Cast, not heat treatable.	General purpose alloy for moderately stressed pressure die-castings.
-	10.0 to 13.0	-	-	-	-	Cast, not heat treatable	One of the most widely used alloys. Suitable for sand, gravity and pressure die castings. Excellent foundry characteristics. Used for large marine, automotive and general engineering castings.
4.2	0.7	0.7	0.7	0.7	0.3 Titanium (option)	Wrought. Heat treatable.	Traditional 'Duralumin'. General machining alloy. Widely used for stressed components in aircraft.
-	0.5	-	-	0.6	-	Wrought. Heat treatable.	Corrosion-resistant alloy for lightly stressed components such as glazing bars, window sections and automotive body components.
1.8	2.5	1.0	-	0.2	0.15 Titanium 1.2 Nickel	Cast. Heat treatable.	Suitable for sand and gravity die casting. High rigidity with moderate strength and shock resistance. A general purpose alloy
-	-	-	-	10.5	0.2 Titanium	Cast. Heat treatable.	A strong, ductile and highly corrosion-resistant alloy used for aircraft and marine castings, both large and small.

Simple scrapers and scraping

Objectives: At the end of this lesson you shall be able to

- state the necessity of scraping surfaces
- state what is high spots
- state what is bearing surface
- list the types of scrapers used, material and size
- hold the scraper at correct angle/position.

Necessity of scraping surface: Scrapers are used to correct slight errors on all flat or curved surfaces that must be finished more decorately.

Scraping is used to produce a high degree of fit between two flat or two curved surfaces particularly where the surfaces can rub together in use.

After a surface is filed or machined as accurately as possible, it can be further improved by rough scraping after which finish scraping is employed. Finish scraping is used to remove minute amount of material.

High spots and bearing surfaces: On the surface plate apply the coating of Prussian blue or red lead mixed with oil or apply used carbon. Placing the job to be scraped, move the job under light downward pressure keeping all edges of the job within the limits of surface. Carefully lift off the job in a perpendicular direction.

Study the patches of marking compound before you begin scraping.

- First test having 3 shiny patches. Only patch 3 would be scraped (high spots) (Fig 1)

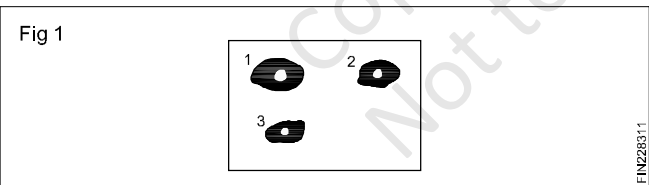

- Second test having even distribution of marking compound. (High spots) (Fig 2)

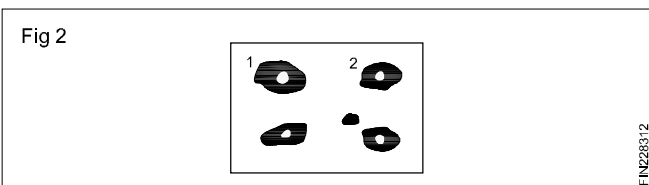

- Types of bearing contact obtained (Fig 3)
- 1 Metal contact with the surface plate. The points have been rubbed shiny.
 - 2 They have been conduct with the marking compound and coloured by it. This portion is called normal contact point.

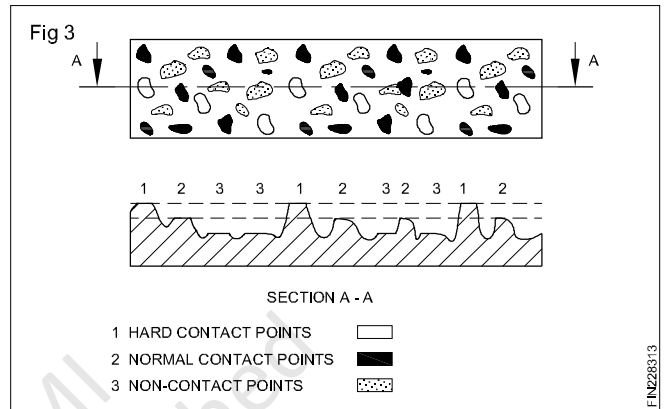

- 3 Non-contact point, have not been in contact with the marking compound.

- After third scraping completed and testing the shining shows the shiny spots are more than those coloured with marking compound. The patches are greater in number in size more evenly distributed. (High spots) (Fig 4)

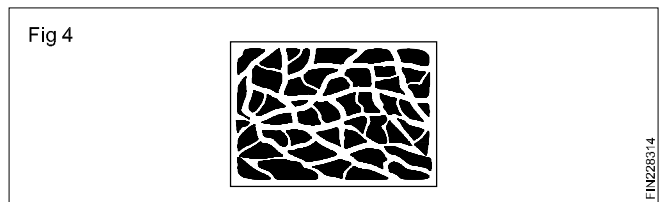

- The enlarged view of the pattern of scraping marks on the small patches shown in Fig 5.

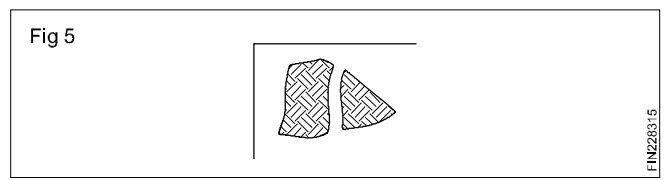

- Further testing, scraping would produce a more even distribution of larger number of smaller sized patches (bearing spots). (Fig 6)

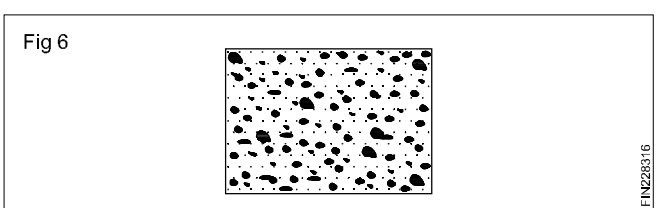

In 25 mm SQ = 25 bearing parts.

Types and uses of scraper: For scraping flat surfaces

- Flat scrapers with rectangular blades. (Fig 7)

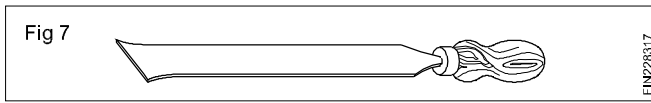

Used for scraping large flat surfaces. The working edge is not thicker than 3 mm.

- Hook scrapers with rectangular blades. (Fig 8)

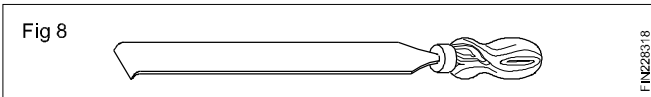

Hook scrapers are used for scraping the center portion of large flat surface where it is not convenient to use of flat scraper.

For scraping curved surfaces

- Half round scraper is curved slightly towards the curved surfaces. (Fig 9)

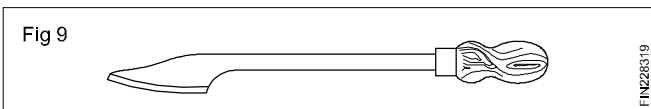

It is used to scrape bearing blocks or brasses, pressure is applied in radial direction and cutting edge moved at right angles to its length. So that scraping marks are circumferential.

- Three square or triangular scraper

Each of the three faces are hallow ground Fig 10. It is used for scraping small diameter holes and deburring edges of accurate holes. The cutting edge is moved at right angles to its length.

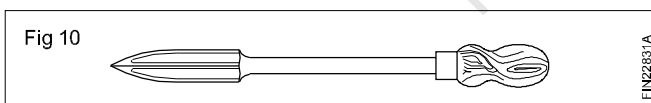

- Bull-nose scraper is forged to a disc like end. (Fig 11) It is used for scraping large bearings. It can be used two ways either with the circumferential movement of a flat scraper or with the longitudinal movement of flat scraper.

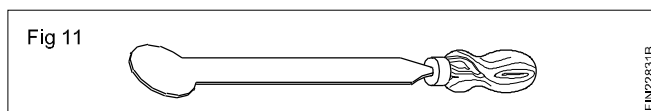

Scraper material: High grade tool steel or special alloy steel and tungsten carbide tipped tool.

Specification: The overall length of blade and handle may range from 150 to about 500 mm.

Holding position of flat scraper: The handle of the scraper is held and pushed by right hand. Hold the right elbow out of from the body when beginning forward cutting stroke. As you finish the short cutting stroke bring the elbow into the body.

The blade is guided and pressed down by the left hand. Grasp the blade with the root of the little finger above the blade and about 40 mm to 50 mm from the cutting edge. (Fig 12)

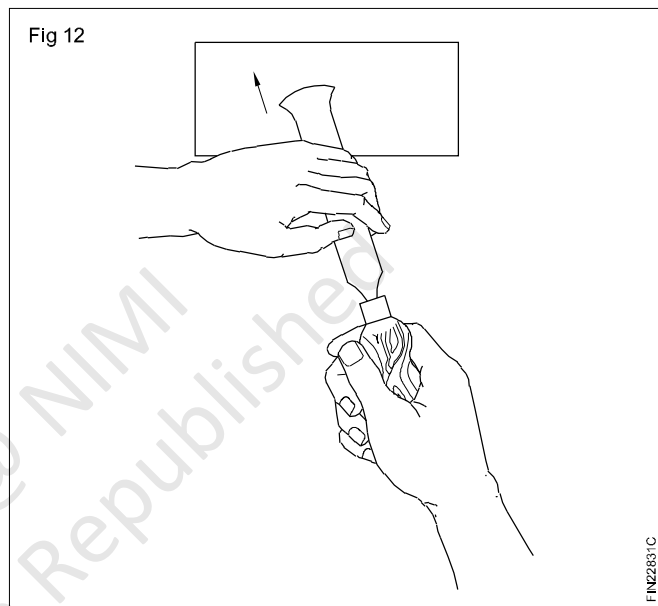

Curl the little finger and second finger lightly around the blade. The first finger lies loosely around the blade and thumb lies on top of the blade and at right angle to it.

For work of average hardness blade of scraper is held at an angle about 30° to surface. For very hard work the angle may be greater, while for softer metals this angle may be decreased to about 20°. (Fig 13)

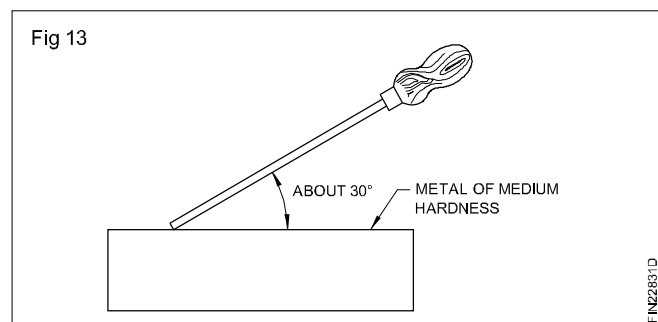

After scraping in one general direction and testing in the surface plate. Change the general direction of scraping by about 90°. (Fig 14)

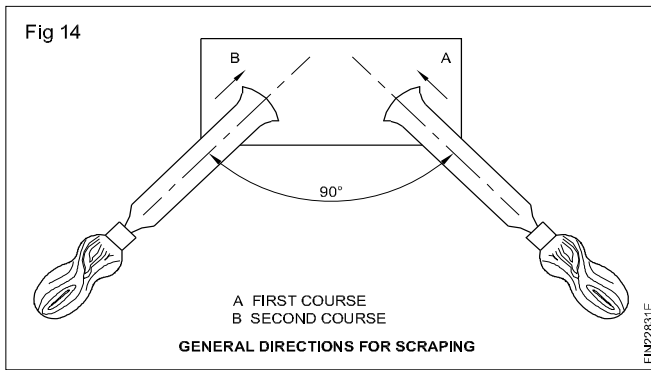

Care and maintenance of scrapers

- Scrapers must be sharp and kept with good condition to handle.
- Cover the cutting edge with rubber or leather sheath.
- After use apply grease on cutting edge to avoid corroding.
- Scraper should not fall down from the bench.
- Don't mix with other tool.

Originating true flat surfaces by three-plate method (Whitworth principle)

Objective: At the end of this lesson you shall be able to

- originate flat scraped surfaces by the three-plate method.

How does one obtain a flat surface?

It is easy to say that it is scraped but how does one know where to take off the high points.

If three plates are compared with one another in alternate pairs, they will only mate perfectly in all positions when they are absolutely flat. (Fig 1)

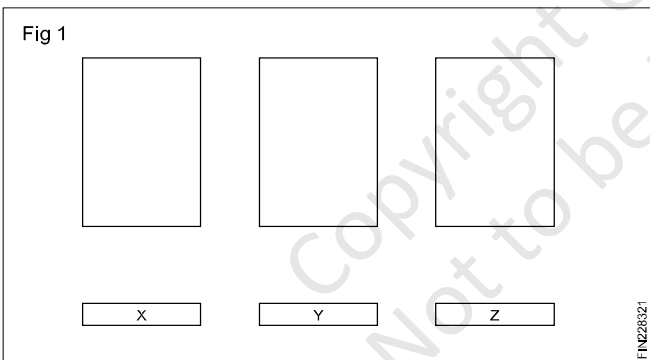

File and ensure that all the three plates are finished to size and square. (Fig 2)

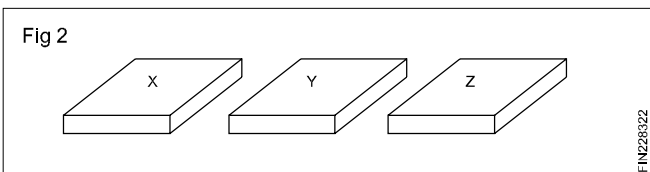

Check the level with the knife edge/straight edge

Stamp the plates X, Y and Z with a letter punch.

Apply a very thin uniform coating of Prussion blue on the faces of plates X and Y which are to be scrapped. (Fig 3)

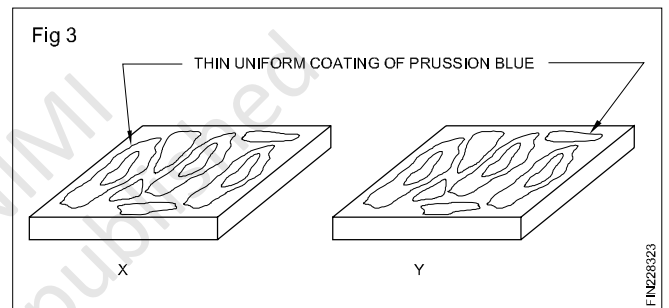

Keep both the pieces together and rub the plates back and forth against each other. (Fig 4)

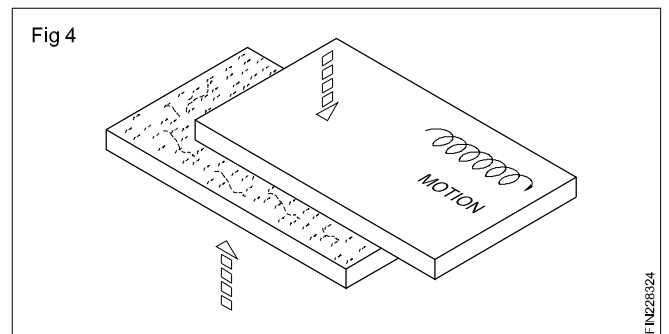

Observe the high spots on the plates X and Y remove by scraping. (Fig 5)

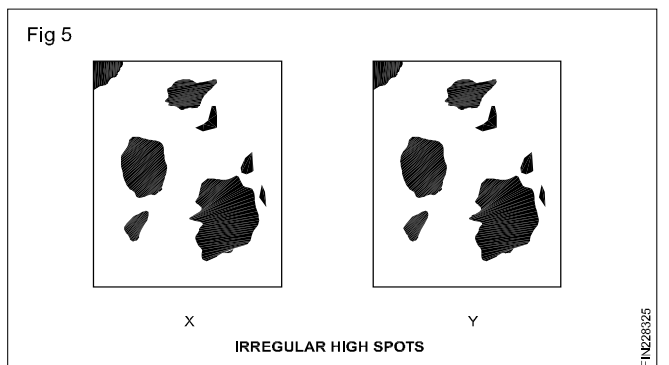

Clean the faces with knitted cotton cloth.

Rub with an oilstone gently to remove the burrs and again clean with knitted cotton cloth.

Repeat the same procedure till both the faces are mating with good bearing surfaces.

Apply a very thin uniform coating of Prussion blue on the face of the plate Z which is to be scraped.

Keep the faces of the plates X and Z together and rub the plates back and forth against each other.

Observe the high spots on the plate Z and remove by scraping (Figs 6 and 7)

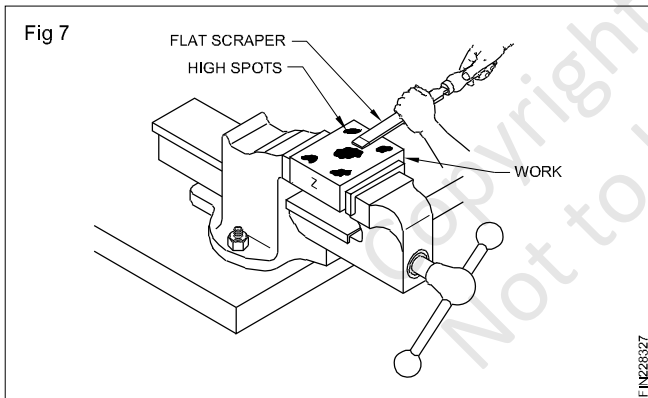
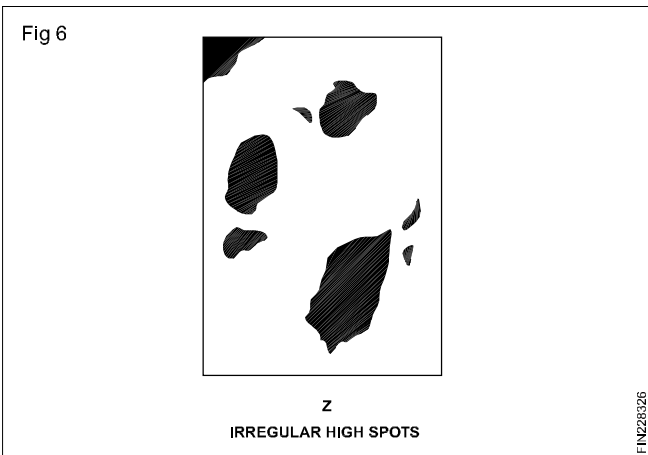

Do not scrape plate X. This is taken as a reference surface.

Repeat the same procedure till both the faces of the plates X and Z are mating with good

Repeat the procedure till the faces of plates Y and Z are mating with good bearing surfaces.

Now one cycle of operation is completed.

Note: Plate X will mate with plates Y and Z but Y and Z will not mate. All the three plates mate only when all the three are flat.

Repeat the cycle a number of times till interchangeable, flat, good bearing surfaces are achieved.

Clean all the plates with kerosene.

Use knitted cotton cloth for cleaning.

A good bearing surface is achieved when 5 to 10 points are visible and uniformly distributed per cm² on the workpiece surfaces after finishing. (Fig 8)

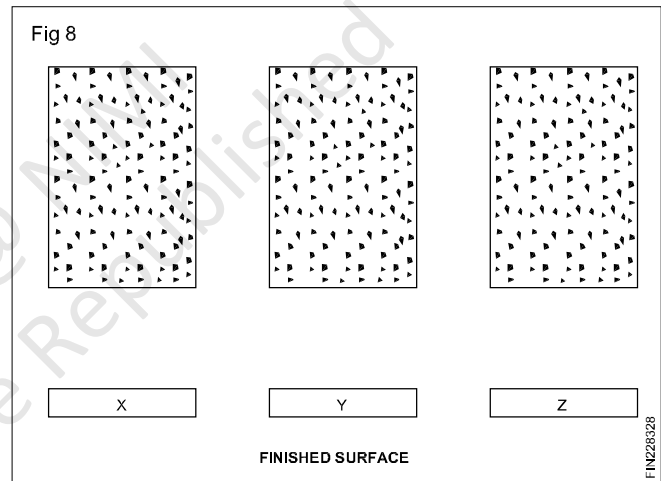

Three trainees will work in a group for this exercise.

Each trainee will be given one plate for scraping.

Each trainee will compare his plate with those of the other trainees as per the above procedure and generate flat surfaces by the three-plate method.

Scraping curved surfaces

Objective: At the end of this lesson you shall be able to

- **scrape and test curved surfaces.**

A half round scraper is the most suitable scraper for scraping curved surfaces. This method of scraping differs from that of flat scraping.

Method

For scraping curved surfaces the handle is held by hand in such a way as to facilitate the movement of the scraper in the required direction. (Fig 1)

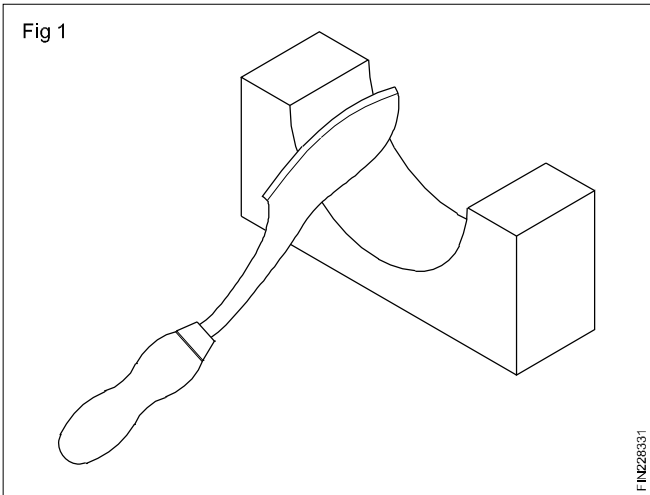

Pressure is exerted with other hand on the shank for cutting.

Rough scraping will need excessive pressure with longer strokes.

For fine scraping, pressure is reduced and the stroke length also becomes shorter.

Cutting action takes place both on forward and return strokes. (Fig 2)

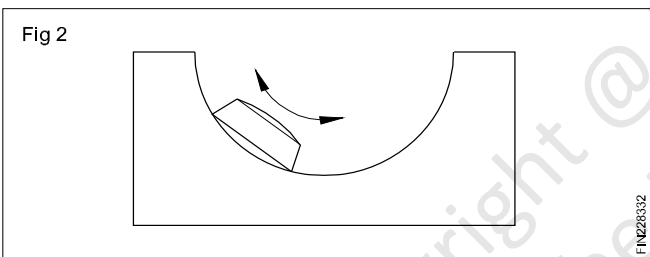

During the forward movement one cutting edge acts, and on the return stroke, the other cutting edge acts.

After each pass, change the direction of cutting. This ensures a uniform surface. (Figs 3 & 4)

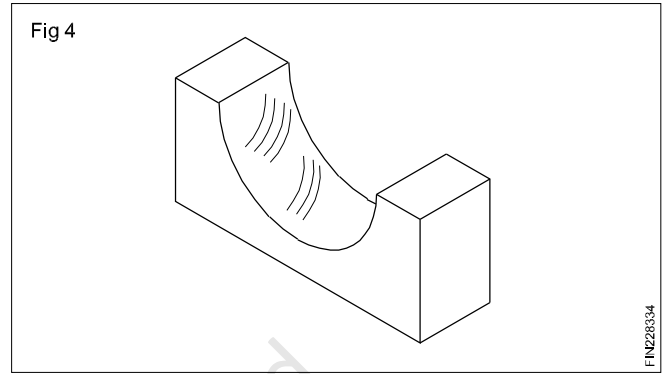
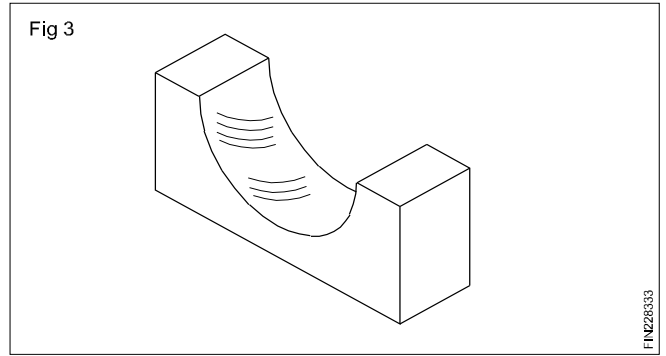

Use a master bar to check the correctness of the surface being scraped. (Fig 5)

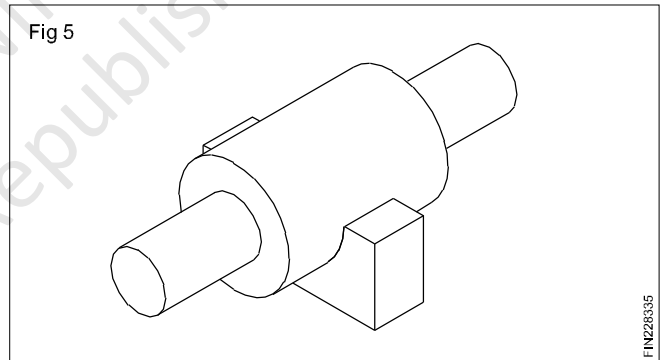

Apply a thin coating of Prussion blue on the master bar to locate the high spots.

Vernier micrometer, screw thread micrometer, graduation & reading

- Objectives:** At the end of this lesson you shall be able to
- state the graduations of a vernier micrometer (metric)
 - read a vernier micrometer

Vernier micrometer

Ordinary metric micrometers can measure only to an accuracy of ± 0.01 mm.

For taking more accurate measurements, vernier micrometers are useful. Vernier micrometers can measure to an accuracy of ± 0.001 mm.

Construction and graduation

Vernier micrometers are very similar to ordinary micrometers in construction. The difference is in the graduation. These micrometers have additional, equally spaced graduations (vernier graduations) given above the datum line. There are ten such vernier graduation lines marked parallel above the datum line. (Fig 1) The space between these 10 lines is equal to 9 divisions in the thimble. (Fig 1)

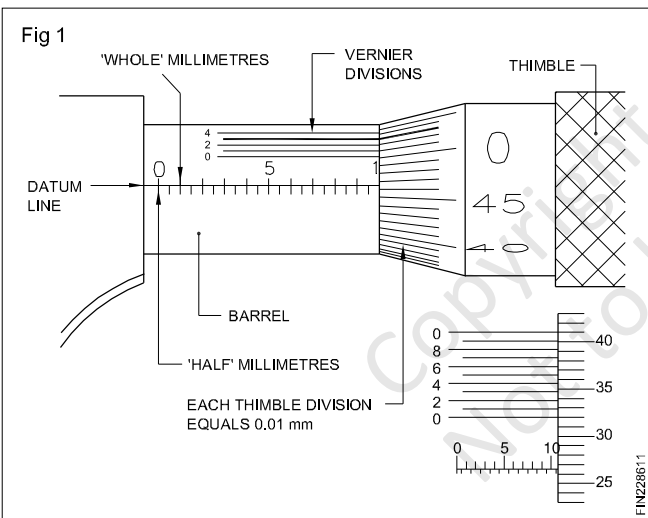

The value of 10 vernier divisions is

$$.01 \text{ mm} \times 9 = .09 \text{ mm.}$$

The value of a vernier division

$$\frac{0.09}{10} = .009 \text{ mm}$$

The least count = 1 thimble division – 1 Vernier division
= $0.01 - 0.009 \text{ mm} = .001 \text{ mm}$

Reading a vernier micrometer (Fig 2)

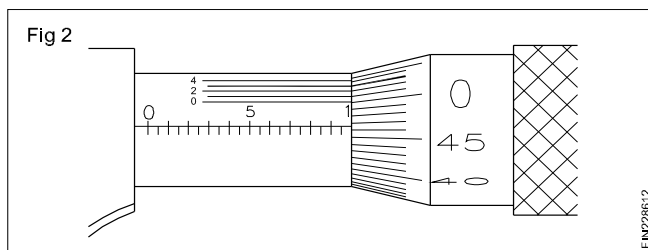

Example

After measuring, read the full mm divisions visible on the barrel.

full divisions in mm. 9 mm

Note the half divisions, if any, visible on the barrel.

1 half division

Read the thimble divisions below the datum line. (Fig 2)

46 divisions

Note the vernier division coinciding with the thimble division.

3rd division

Add up all the readings together

Calculation

The range of micrometer is 0 to 25 mm

- | | |
|--|---------------------------------------|
| A Full mm division visible before the thimble edge | $= 1.00 \times 9 = 9.00 \text{ mm}$ |
| B Half mm division visible after the full mm division on barrel. | $= 0.5 \times 1 = 0.50 \text{ mm}$ |
| C Thimble division below the index line | $= 46 \times 0.01 = 0.46 \text{ mm}$ |
| D Vernier division coinciding with thimble division | $= 3 \times 0.001 = 0.003 \text{ mm}$ |
| Reading | $= 9.963 \text{ mm}$ |

Vernier micrometers are made of invar steel. (Fig 3)

Fig 3

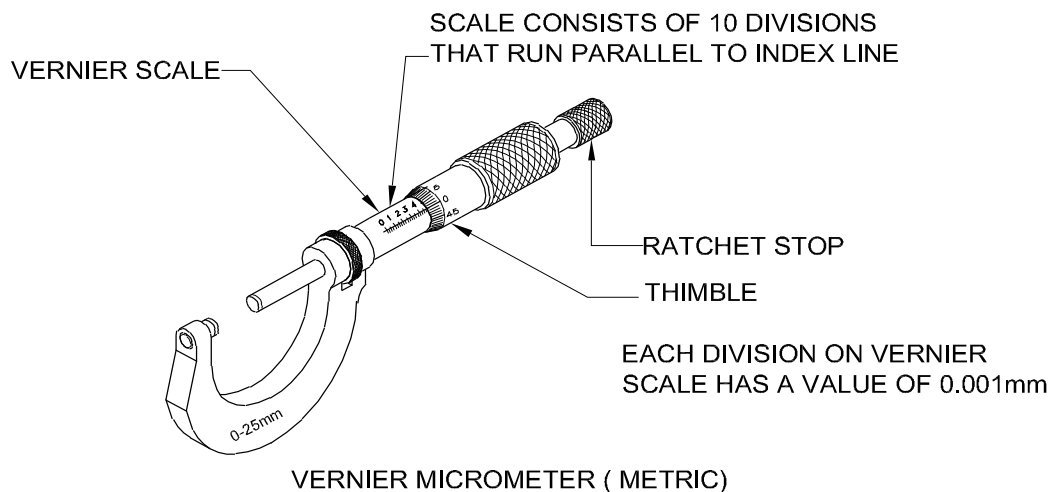

FINZ28613

Care and maintenance

- Clean the circumference of the spindle and both measuring faces with dry linen cloth regularly before use.
- Clean and apply thin layer of oil on the spindle and measuring faces after the use.
- Care should be taken while handling the micrometer and not to drop on floor.
- Recalibrate the vernier micrometer if it is accidentally dropped.
- Store vernier micrometer in a ventilated place with low humidity and ideally at room temperature.
- Ensure that there is a gap between measuring faces, when it is not in use.

Calibration of measuring instrument

Objectives: At the end of this lesson you shall be able to

- state the importance of calibration
- state calibration and its procedure.

Why calibration is important ?

The accuracy of all measuring devices degrade over time. This is typically caused by normal wear and tear. However, changes in accuracy can also be caused by electric or mechanical shock or a hazardous manufacturing environment in which it is being used, it may degrade very quickly or over a long period of time. The bottom line is that, calibration improves the accuracy of the measuring device. Accurate measuring devices improve product quality.

When should you calibrate your measuring device?

A measuring device should be calibrated:

- According to recommendation of the manufacturer.
- After any mechanical or electrical shock.
- Periodically (annually, quarterly, monthly).

What is calibration

Calibration is defined as a scientific and systematic method of identifying deviations (error) in a instrument by comparing with a master, having higher accuracy and rational traceability.

It is also referred as checking the integrity of an instrument, alternately ascertaining whether the instrument is fit enough to be used for measurement.

The instrument calibration is carried out as per (ISS) Indian Standard Specification published by the Bureau of Indian standards (BIS), which also gives the permissible error, that can be allowed in the relevant standard for each instrument.

Calibration is mandatory in most of the global quality standards and is covered under a special clause called measuring system analysis (MSA) for automobile industry standard ISO/TS 16949. Calibration should be carried out by an accredited laboratory or by following relevant documents of the certifying agency, NABL India (National Accreditation Board for calibration testing laboratories, the accrediting body in our country.

A part from following the standard specification for calibration of an instrument, the environmental condition of the lab is critical with respect to temperature, humidity, vibrations proper lighting, magnetic interference etc., which are specified in IS:199 or the NABL document, essential criteria for the calibration lab, which should adopt the

quality system standard (QSS) as per ISO/IEC/170235 - 2015. The vital factor in calibration of an instrument is the frequency of calibration, which is determined based on the importance & criticality of the measurement process.

A good calibrated instrument will maintain both precision & accuracy, the essential requirement of any measuring system

Calibration of your measuring instruments has two objectives. It checks the accuracy of the instrument and it determines the traceability of the measurement. In practice, calibration also includes repair of the device if it is out of calibration. A report is provided by the calibration expert, which shows the error in measurements with the measuring device before and after the calibration.

To explain how calibration is performed we can use an external micrometer as an example. Here, accuracy of the scale is the main parameter for calibration. In addition,

these instruments are also calibrated for zero error in the fully closed position and flatness and parallelism of the measuring surfaces. For the calibration of the scale, a calibrated slip gauge is used. A calibrated optical flat is used to check the flatness and parallelism.

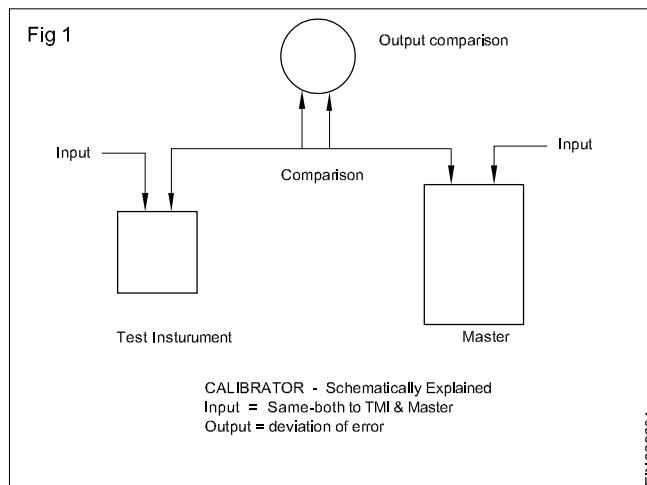

Mechanical fasteners

Objectives: At the end of this lesson you shall be able to

- define mechanical fasteners
- classification of fasteners
- state the application of various fasteners & their uses.

Definition

A mechanical fastener is a device that mechanically joins two (or) more components together easily and also can be dismantled without damaging any components using hand tools (or) power tools.

Classification

According to the need and usage they are classified into three categories.

- Temporary (or) removable fasteners
- Semi permanent fasteners
- Permanent fasteners

Temporary (or) removable fasteners

- The fasteners like bolts, nuts, screws, studs etc., enable us to join two (or) more components easily and also can be dismantled without damaging any component using hand tools (or) power tools.
- The most common types of male fasteners used in industry are hexagonal head, square head, flat (or) countersunk head, round head, socket head (or) allen head, button head and socket set screws etc.
- The most common types of female fasteners (ie nuts) used in industry are regular hexagonal nut, square nut, round nut and nylon ring elastic stop nuts etc.

Uses

These types of fasteners are used for assembling two (or) more components together to make a sub-assembly (or) to make a full assembly.

Semi permanent fasteners

The fasteners like rivets are used to hold the plates (or) steel sections firmly. The rivets are placed through the pre drilled appropriate holes in parts to be joined (or) assembled. By using rivet sets, the tail part of the shank is formed into the head closing the hole.

The plates are held between the heads on cooling. Rivet is a cylindrical rod either carbon steel (or) wrought iron (or) non-ferrous metal. It consists of a head and shank tapering at the end facilitating easy placement in the rivet holes. During dismantling the rivets may be drilled to remove the plates already joined together without spoiling them. This process is a permanent as well as a semi-permanent in nature. According to the head type the rivets are called snap head, pan head, countersunk head, flat head etc.

Uses

Rivets are used in ship building, bridge girders, structural towers, goods wagons, boilers and heavy pressure vessels industry and also for small scale applications too.

Permanent fasteners

Arc welding, gas welding and brazing are the operations used in industry during permanent fastening of components and structures. Once the arc welding, gas welding and brazings has been done, the components (or) the structures cannot be separated without damage, hence these type of fastening is called permanent fastening.

Uses

To hold steel plates (or) structures together like goods wagon building, ship building, bridge structures assembling etc. Sometimes before doing welding the components (or) the parts hold together with temporary fasteners like bolts, nuts, screws, rivets etc.

Screw thread micrometer - Thread measurement (effective diameter) using screw thread micrometer

Objectives: At the end of this lesson you shall be able to

- state the features of a screw thread micrometer
- state the features of the three-wire system of measurement with the help of tables
- select the best wire with the help of tables for using in the three-wire method.

The Screw thread micrometer: This micrometer (Fig 1) is used to measure the effective diameter of the screw threads. This dimension is important, because the area of the thread flanks in the vicinity of the pitch line is where the greatest transmission of force occurs between mating threads.

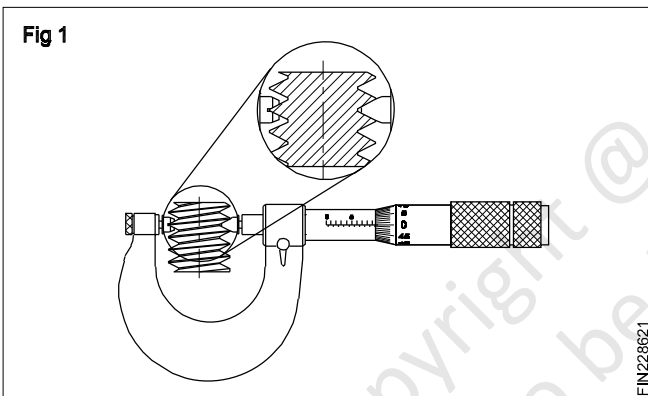

This is very similar to the ordinary micrometer in construction but has facilities to change the anvils.

The anvils are replaceable and are changed according to the profile and pitch of the different systems of threads. (Figs 2 & 3)

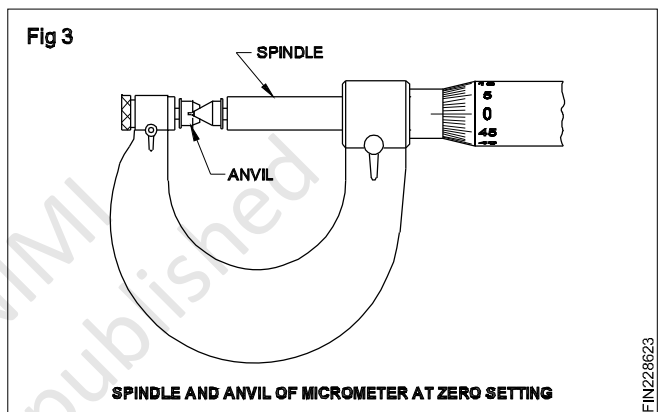
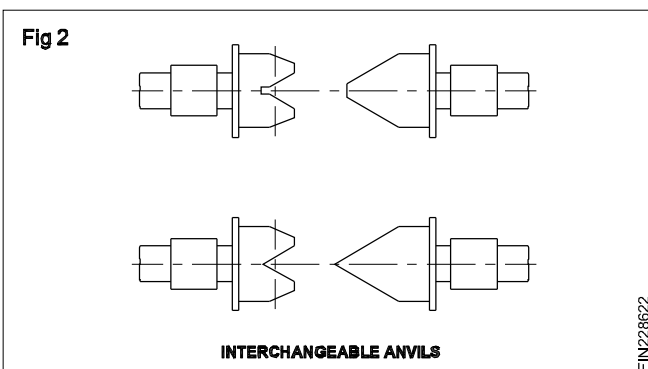

The three-wire method: This method uses three wires of the same diameter for checking the effective diameter and the flank form. The wires are finished with a high degree of accuracy.

The size of the wires used depends on the pitch of the thread to be measured.

For measuring the effective diameter, three wires are suitable placed between the threads. (Fig 4)

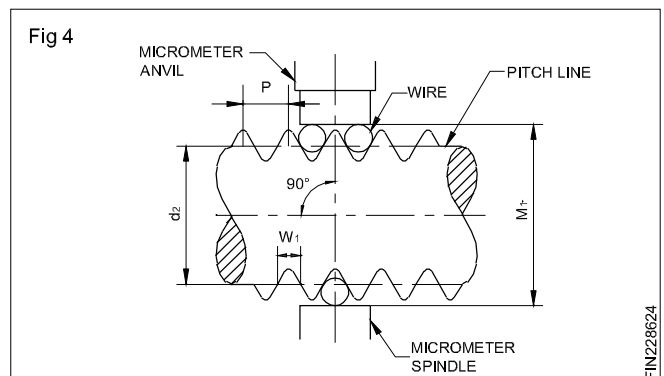

The measuring wires are fitted in wire-holders which are supplied in pairs. One holder has provisions to fix one wire and the other for two wires. (Fig 5)

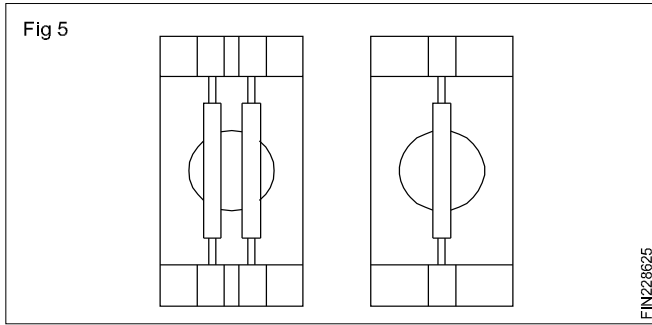

While measuring the screw thread, the holder with the one wire is placed on the spindle of the micrometer and the other holder with two wires is fixed on the anvil. (Fig 6)

Selection of 'best wire' (Fig 7): The best wire is the one which, when placed in the thread groove, will make contact at the nearest to the effective diameter. The selection of the wire is based on the type of thread and pitch to be measured. The selection of the wire can be calculated and determined but readymade charts are available from which the selection can be made.

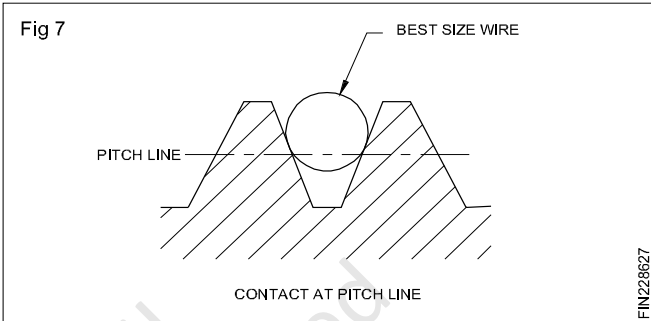
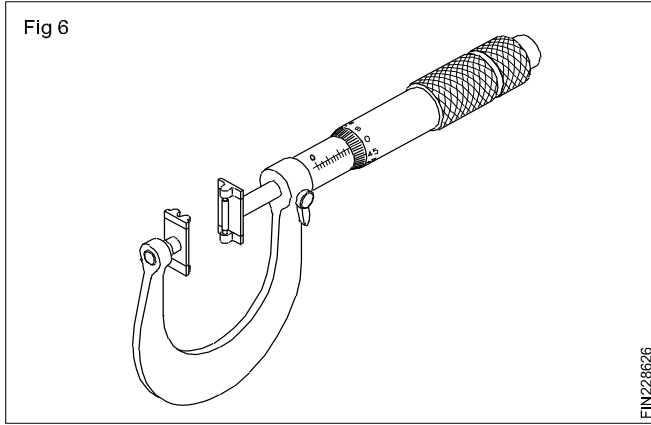

Copyright @ NIMI
Not to be Republished

Table 1

Measurement with measuring wires. Metric threads with coarse pitch (M)

Thread designation	Pitch P (mm)	Basic measurement mean d_2 (mm)	Measuring wire dia. W_1 (mm)	Dimension over wire M_1 (mm)
M1	0.25	0.838	0.15	1.072
M 1.2	0.25	1.038	0.15	1.272
M 1.4	0.3	1.205	0.17	1.456
M 1.6	0.35	1.373	0.2	1.671
M 1.8	0.35	1.573	0.2	1.870
M 2	0.4	1.740	0.22	2.055
M 2.2	0.45	1.908	0.25	2.270
M 2.5	0.45	2.208	0.25	2.569
M 3	0.5	2.675	0.3	3.143
M 3.5	0.6	3.110	0.35	3.642
M 4	0.7	3.545	0.4	4.140
M 4.5	0.75	4.013	0.45	4.715
M 5	0.8	4.480	0.45	5.139
M 6	1	5.350	0.6	6.285
M 8	1.25	7.188	0.7	8.207
M 10	1.5	9.026	0.85	10.279
M 12	1.75	10.863	1.0	12.350
M 14	2	12.701	1.15	14.421
M 16	2	14.701	1.15	16.420
M 18	2.5	16.376	1.45	18.464
M 20	2.5	18.376	1.45	20.563
M 22	2.5	20.376	1.45	22.563
M 24	3	22.051	1.75	24.706
M 27	3	25.051	1.75	27.705
M 30	3.5	27.727	2.05	30.848

Table 2

Measurement with measuring wires. Metric threads with fine pitch (M)

Thread designation	Basic measurement d_2 (mm)	Measuring wire dia.mean W_1 (mm)	Dimension over wire M_1 (mm)
M 1 x 0.2	0.870	0.12	1.057
M 1.2 x 0.2	1.070	0.12	1.257
M 1.6 x 0.2	1.470	0.12	1.557
M 2 x 0.25	1.838	0.15	2.072
M 2.5 x 0.35	2.273	0.2	2.570
M 3 x 0.35	2.773	0.2	3.070
M 4 x 0.5	3.675	0.3	4.142
M 5 x 0.5	4.675	0.3	5.142
M 6 x 0.75	5.513	0.45	6.214
M 8 x 1	7.350	0.6	8.285
M 10 x 1.25	9.188	0.7	10.207
M 12 x 1.25	11.188	0.7	12.206
M 14 x 1.5	13.026	0.85	14.278
M 16 x 1.5	15.026	0.85	16.278
M 18 x 1.5	17.026	0.85	18.277
M 20 x 1.5	19.026	0.85	20.277
M 22 x 1.5	21.026	0.85	22.277
M 24 x 2	22.701	1.15	24.420
M 27 x 2	25.701	1.15	27.420
M 30 x 2	28.701	1.15	30.419

Dial test indicator, comparators, digital dial indicator

Objectives: At the end of this lesson you shall be able to

- state the principle of a dial test indicator
- identify the parts of a dial test indicator
- state the important features of a dial test indicator
- state the functions of a dial test indicator
- identify the different types of stands.

Dial test indicators are instruments of high precision, used for comparing and determining the variation in the sizes of a component. (Fig 1) These instruments cannot give the direct reading of the sizes like micrometers and vernier calipers. A dial test indicator magnifies small variations in sizes by means of a pointer on a graduated dial. This direct reading of the deviations gives an accurate picture of the conditions of the parts being tested.

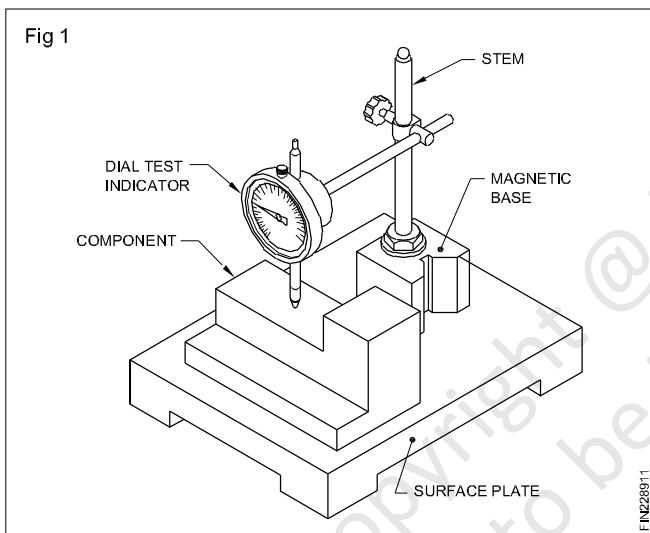

Principle of working

The magnification of the small movement of the plunger or stylus is converted into a rotary motion of the pointer on a circular scale. (Fig 2)

Types

Two types of dial test indicators are in use according to the method of magnification. They are

Plunger type (Fig 3)

Lever type (Fig 4)

The Plunger Type dial test indicator

The external parts and features of a dial test indicator are as shown in figure 3.

Dial test indicators are made out of Inver steel material

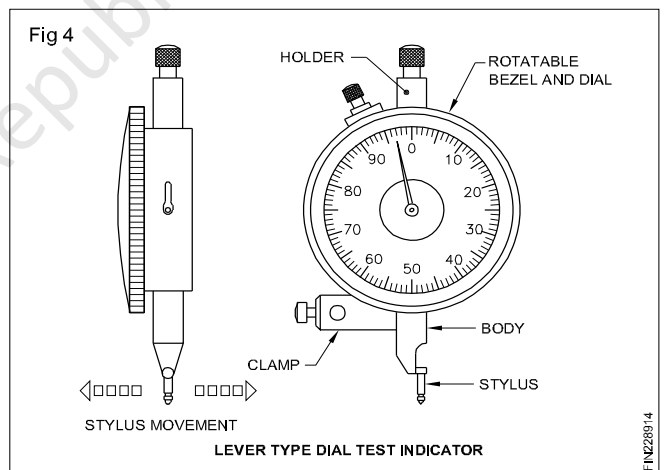
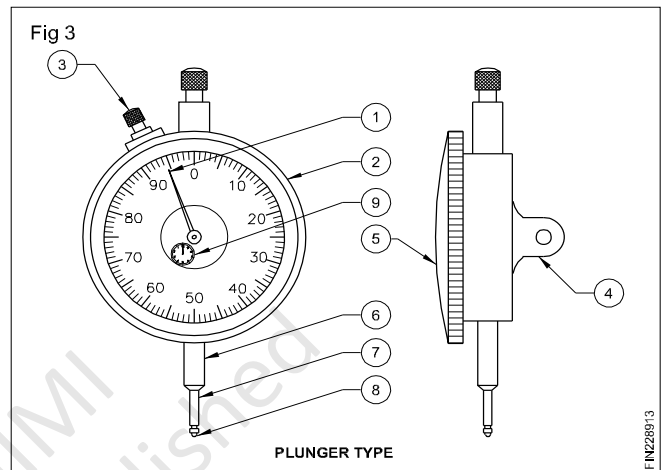

- 1 Pointer
- 2 Rotatable bezel
- 3 Bezel clamp
- 4 Back lug
- 5 Transparent dial cover
- 6 Stem
- 7 Plunger
- 8 Anvil
- 9 Revolution counter

For converting the linear motion of the plunger, a rack and pinion mechanism is used. (Fig 2)

Fig 2

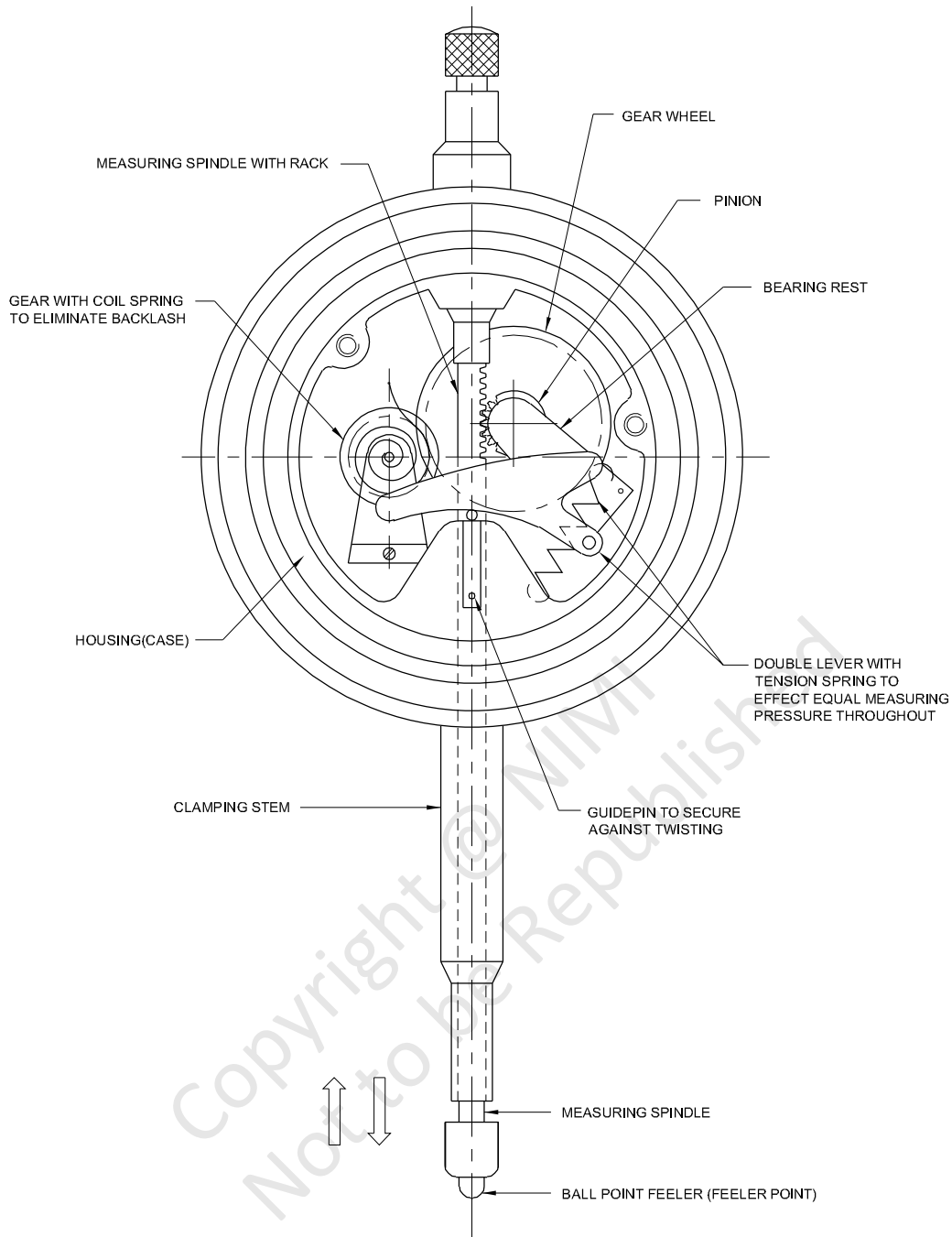

FIN228912

The lever type dial test indicator (Fig 4)

In the case of this type of dial test indicators, the magnification of the movement is obtained by the mechanism of the lever and scroll. (Fig 5)

It has a stylus with a ball- type contact, operating in the horizontal plane.

This can be conveniently mounted on a surface gauge stand, and can be used in places where the plunger type dial test indicator application is difficult. (Fig 6)

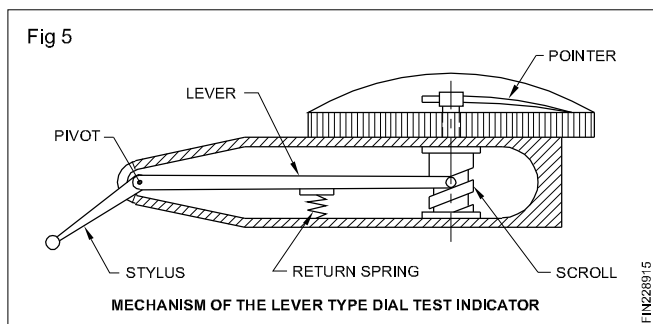

FIN228915

Important features of dial test indicators

An important feature of the dial test indicator is that the scale can be rotated by a ring bezel, enabling it to be set readily to zero.

Many dial test indicators read plus in clockwise direction from zero, and minus in the anti-clockwise direction so as to give plus and minus indications.

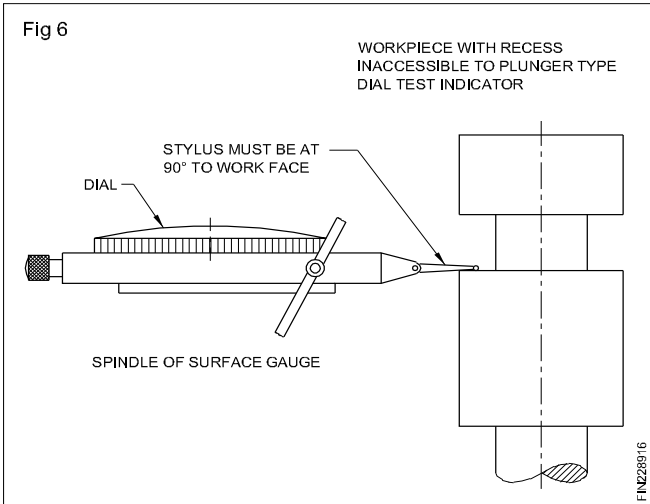

Uses (Figure 7 shows few applications)

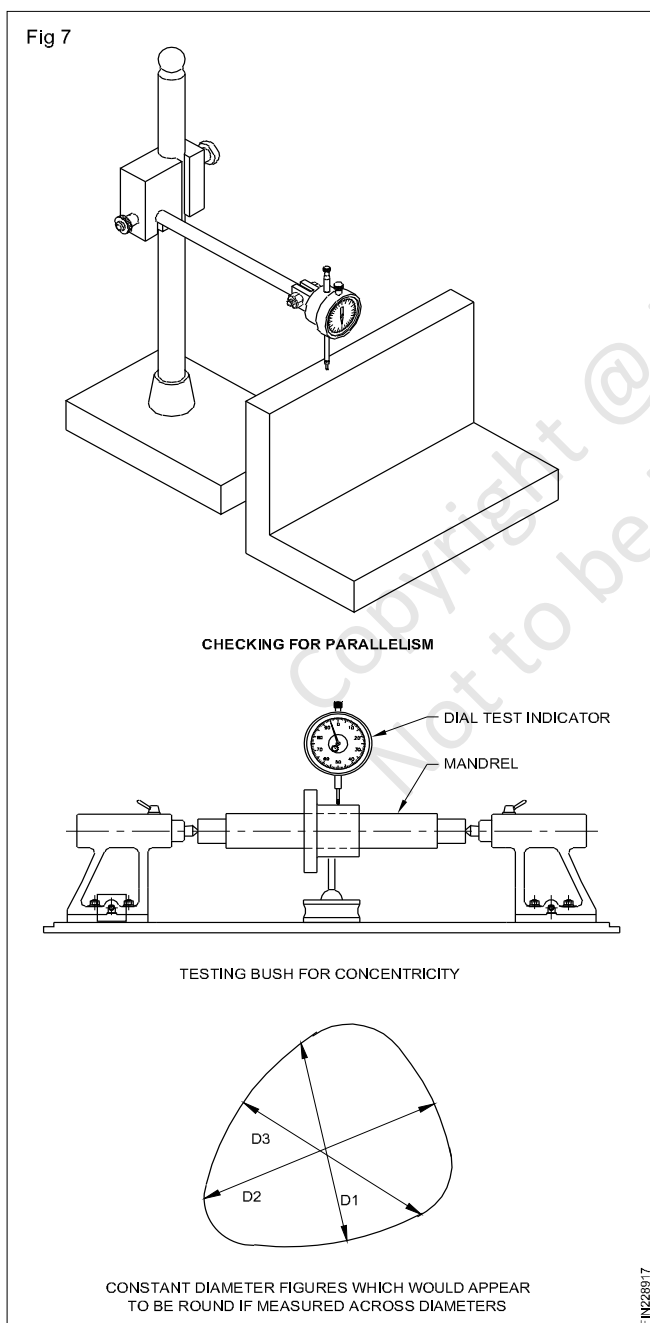

To compare the dimensions of a workpiece against a known standard, eg slip gauges.

To check plane surfaces for parallelism and flatness.

To check parallelism of shafts and bars.

To check concentricity of holes and shafts.

Indicator stands (Fig 8)

Dial test indicators are used in conjunction with stands for holding them so that the stand itself may be placed on a datum surface of machine tools.

The different types of stands are (Fig 9)

- Magnetic stand with universal clamp
- Magnetic stand with flexible post
- General purpose holder with cast iron base.

The arrows indicate the provisions in the clamps for insertion of the dial test indicator.

Care and maintenance of dial test indicator.

- Keep the dial test indicator spindle and point clean using a soft cloth.
- Store the dial test indicator in a safe, dry place and cover them to keep the dust and moisture out.
- Do the dial test indicator under gaging conditions at intervals during the operating day.

Fig 8

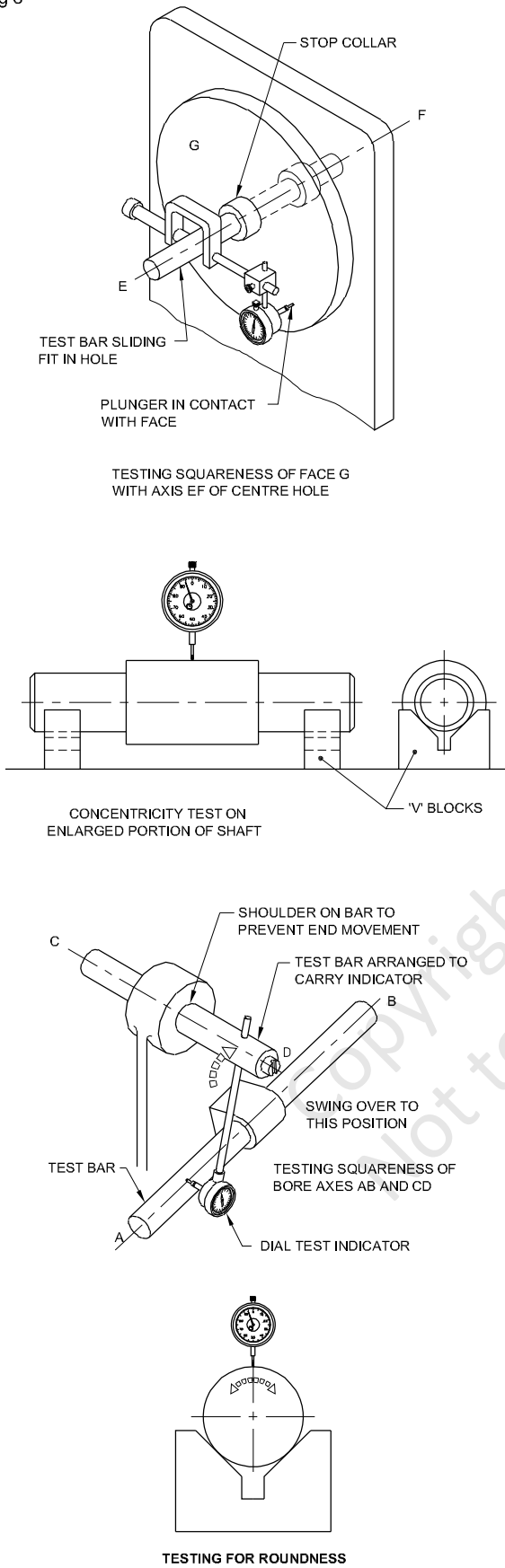
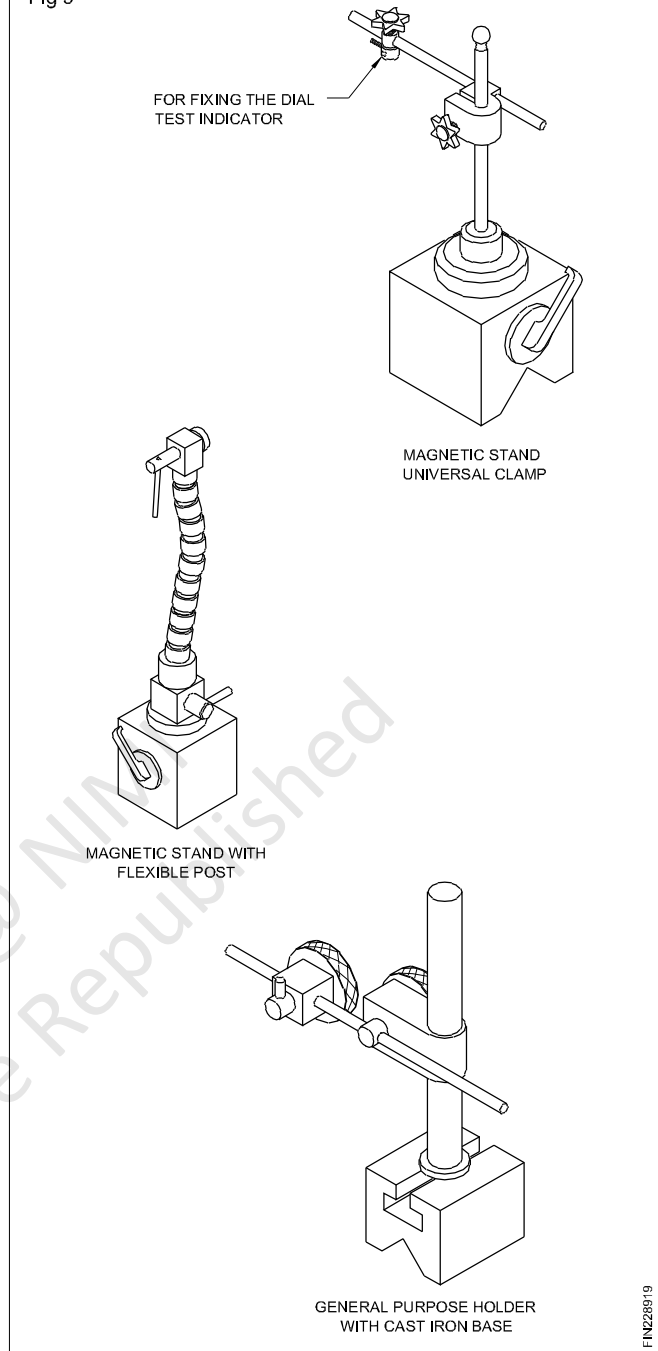

Fig 9



Comparators

Objectives: At the end of this lesson you shall be able to

- state the principle of working of comparator gauges
- state the essential features of a good comparator gauge
- state the purpose of a comparator gauge.

Purpose of a comparator gauge

The purpose of all comparator gauges is to indicate the difference in the size between the standard (slip gauge or ring gauge) and the work being measured by means of some form of pointer on a scale at a magnification which is sufficient to read to the accuracy required. Almost every possible principle known to the Science of Physics for providing magnification has been used for the construction of these comparator gauges.

Essential features of a good comparator gauge

- Should be compact.
- Maximum rigidity.
- Maximum compensation for temperature effects.
- No backlash in the movement of the plunger and recording mechanism.
- Straight line characteristics of the scale readings.
- Most suitable measuring pressure which remains uniform throughout the scale.
- Indicator should be consistent in its return to zero.
- Method of indication should be clear and the pointer 'dead beat' (ie. free from oscillations).
- Should be able to withstand reasonable wrong usage.
- Should have a wide range of operations.

Principles of working

The following principles are employed in the commonly used comparator gauges.

- Mechanical
- Electronics
- Pneumatic
- Optical

Mechanical comparators

These are widely used and the familiar ones are the dial indicator fitted to the comparator stand, microcator, sigma comparator and red comparator.

Dial indicator fitted to the comparator stand.

Here, the plunger type dial indicator is used. The magnification is achieved by a suitable combination of gears, rack and pinion, steel band and levers. Generally the magnification range is between 100 or 1000 (least count 10 micron or 1 micron).

Microcator (Fig 1)

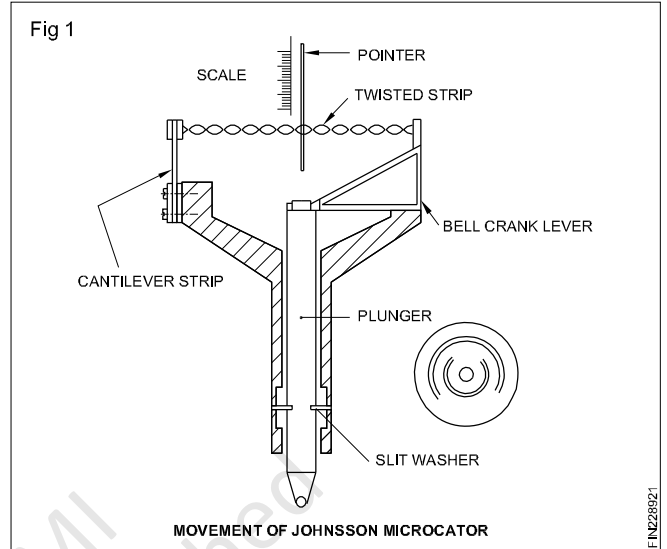

This is a simple and ingenious design, giving a very high magnification up to 25000 times (0.02 μ ie. 0.00002 mm. least count) It is compact, robust and free from friction and backlash.

When the plunger moves up, the bell crank lever is tilted and the twisting strip elongates. The helix angle in the twisted strip reduces and this causes the pointer, which is fixed along the helix of the strip, to move to one side. This movement is then read on the scale fitted behind it. When the plunger moves down, the entire process of movement is reversed and the pointer moves to the opposite side and this reading is read against the scale.

Sigma comparator (Fig 2)

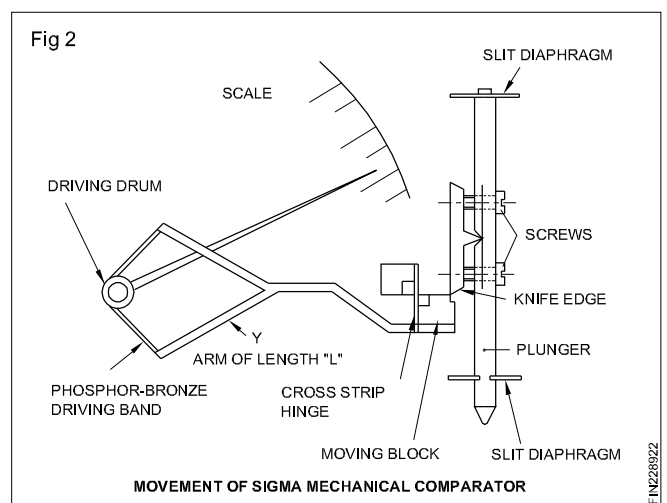

This also gives a magnification of the same order as the microcator. When the plunger moves up, the knife edge resting on the sapphire bearing block also moves up, causing an imbalance to the hinged block which, in turn, causes the 'Y' arm to move down. The phosphor-bronze band drives the drum and causes the pointer to move.

'Red' comparator

This design is also equally popular. Figures 3a, 3b and 3c explain the mechanism of this comparator.

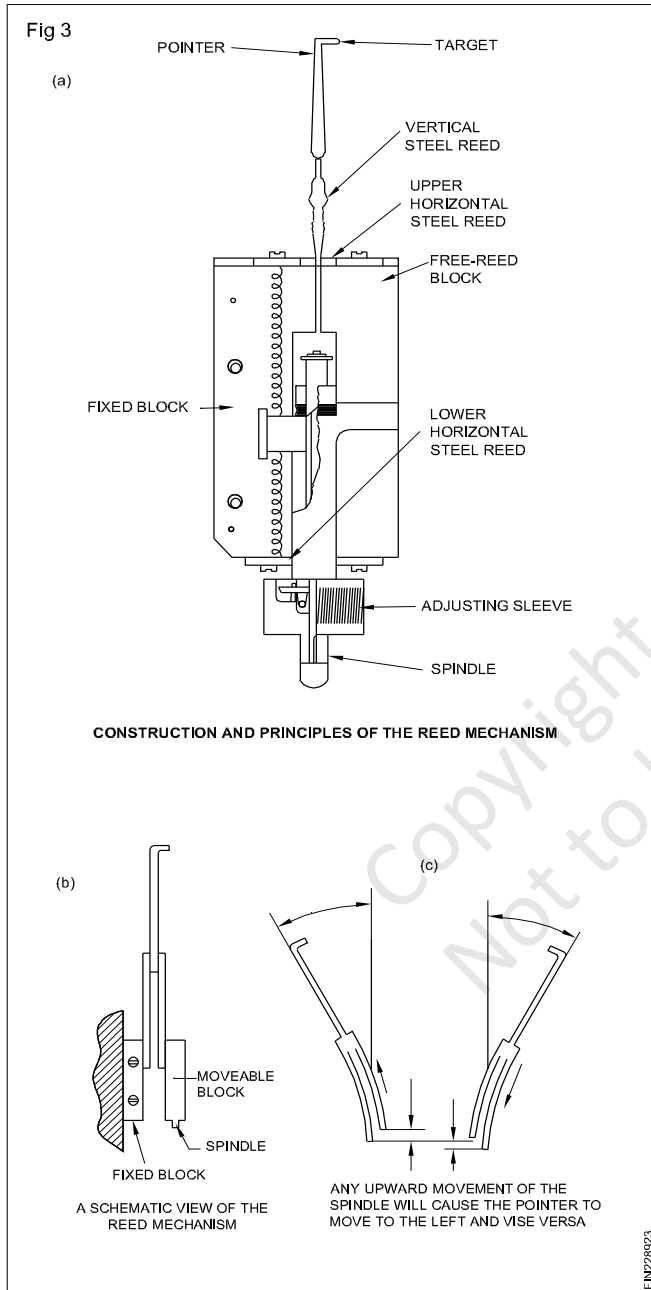

Electrical/Electronic comparator

These are power-amplified with a continuous analogue output. The electronic comparator offers advantages like widely adjustable magnification, electrical zero adjustment, adding or subtracting signals from a number of measuring heads, relay functions etc. (Figs 4a and 4b)

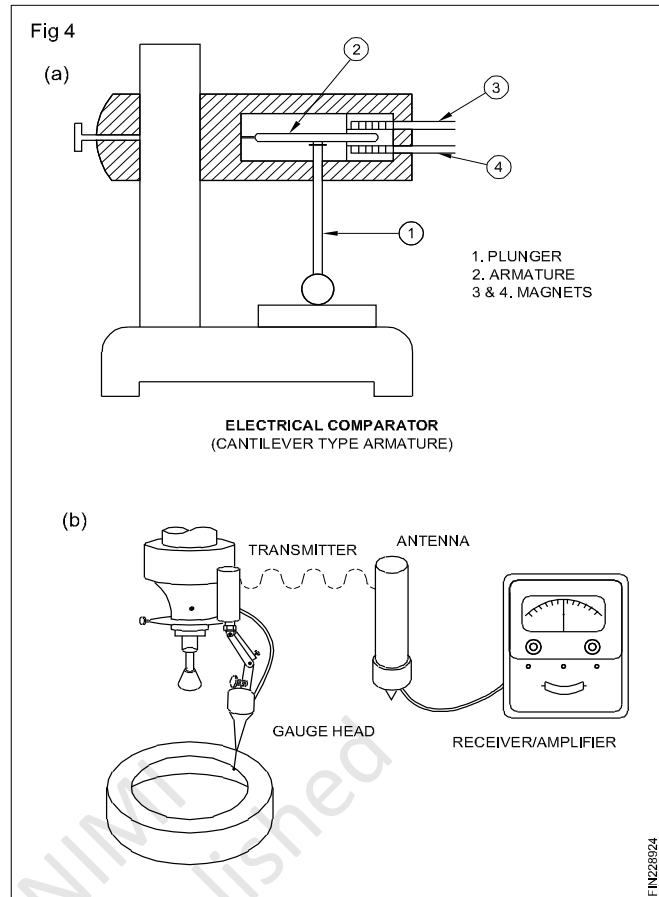

In Fig 4a, as the plunger (1) moves up, the armature (2) is lifted up, causing an imbalance in the electrical field created by the electromagnets (3 & 4). This causes an induced electromotive force in the circuits. These changes are amplified electronically to as much as 100000 times.

Fig 4b shows the electronic gauging system.

Pneumatic comparator (Fig 5)

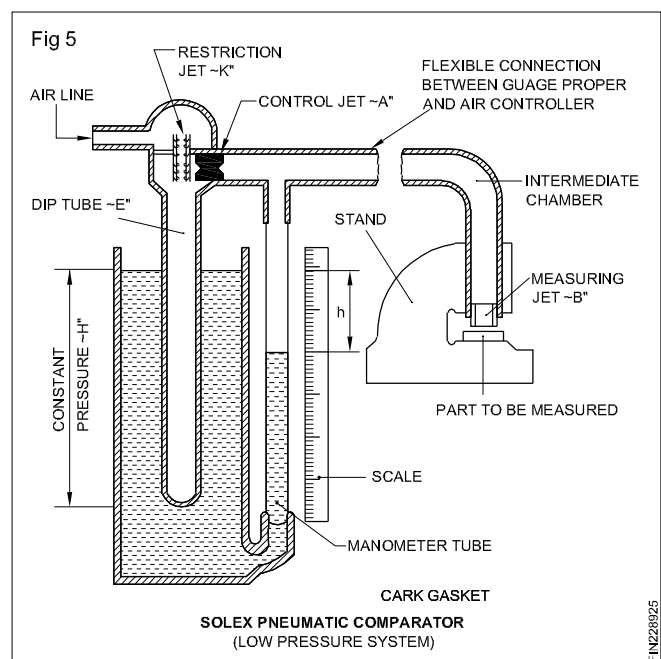

This comparator is fast, rigid, accurate and suitable for use on the shop floor especially in mass production. As no mechanical contact exists between the gauge unit and the measured surface, these are used where other instruments are unsuitable. The air stream from the measuring jet also has a cleaning effect on the measuring surface.

In the figure, as the gap 'd' between the component and the jet 'B' decreases, the outflow of the air experiences some resistance to its free flow. This causes a back pressure in the air-line causing the liquid column inside the manometer tube to go down. When the distance 'd' increases, the liquid column in the manometer tube rises up. These variations 'h' are read from the scale fitted behind the manometer tube which correspond to the variations in 'd'.

Fig 6 explains the pneumatic comparator wherein compressed air at 6 to 10 atmospheric pressure is made use of.

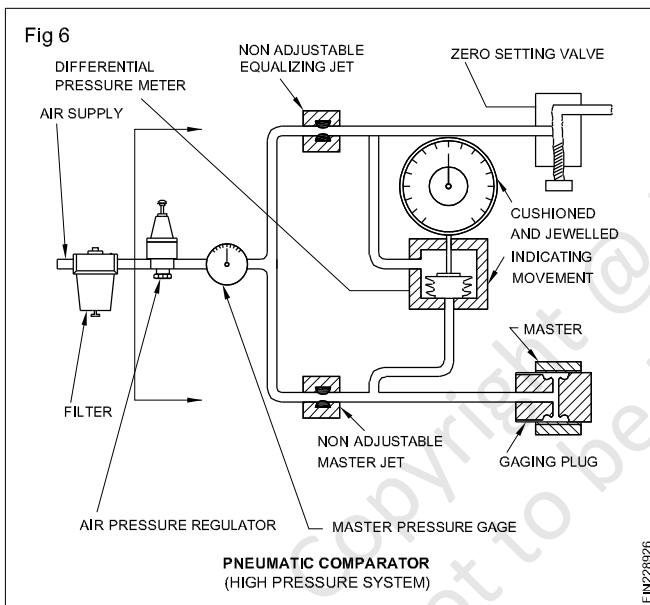

Optical comparator (Fig 7)

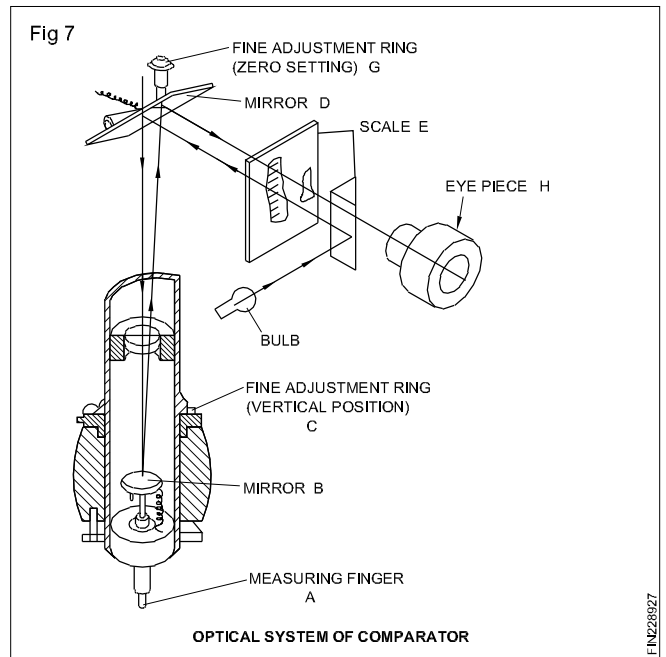

These instruments employ the principle of reflection of light rays. Very large magnifications are attainable and the instrument is free from friction and backlash. Accuracy of measurements upto 1μ is possible with these comparators.

As the measuring plunger goes up, the light ray falling on mirror 'B' gets tilted and the tilted ray falls on mirror 'D' and gets reflected accordingly. This tilt in the light ray is read against the scale 'E' through the eyepiece 'H'.

Digital dial indicator

Objectives: At the end of this lesson you shall be able to

- define digital dial indicator.

Digital dial indicator

With the advent of electronics, the clock face (dial) in some indicators are now a days replaced with digital display (usually LCD's) and the dial readings are also replaced by linear encoders.

Digital indicators have some advantages over their analog predecessors, many models of digital indicator can record and transmit the data electronically through a computer, through an interface such as RS 232 or USB, this facilitates statistical process control (SPC), because a computer can record the measurement results in a tabular dataset (such as database table or spread sheet) and interpret them (by performing statistical analysis on them). This obviates manual recordings of long columns of numbers, which not only reduce the risk of the operator by avoiding errors (such as digit transpositions) but also really improves the productivity of the process by freeing the human efforts from time - consuming data recording and copying tasks.

Another advantages is that they can be switched between metric and british units by the press of a button, thus avoids the provision of separate unit conversion system.

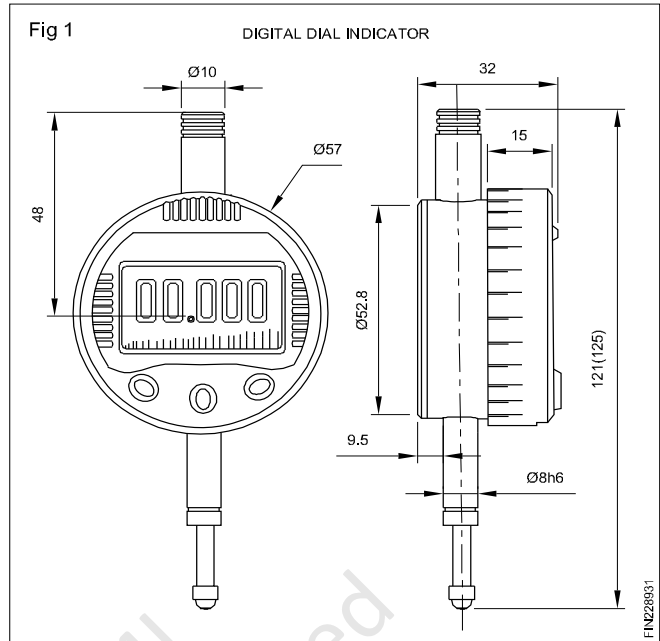

Therefore the digital dial indicator is having more advantage over the ordinary dial indicator.

The digital dial indicator accuracy is 0.001mm in metric and 0.0001 inch in british.

Measurement of quality in cylindrical bore using three point internal micrometer

Objectives: This shall help you to

- state the uses of a three-point internal micrometer
- identify the parts of a three-point internal micrometer
- state the features of the three-point internal micrometer.

The three-point internal micrometers (Fig 1) are useful for:

- Measuring the diameters of through and blind holes.
- Checking cylindricity and roundness of bores.

The commonly used three-point internal micrometers have a least count of 0.005 mm.

Parts

- Measuring head consisting of three measuring anvils
- Ratchet stop
- Thimble
- Barrel

This micrometer has a cone spindle which advances when the thimble is rotated clockwise. The movement of the cone spindle makes the measuring anvils to move forward and backward uniformly. The three measuring anvils facilitate self-alignment of the instrument within the bore.

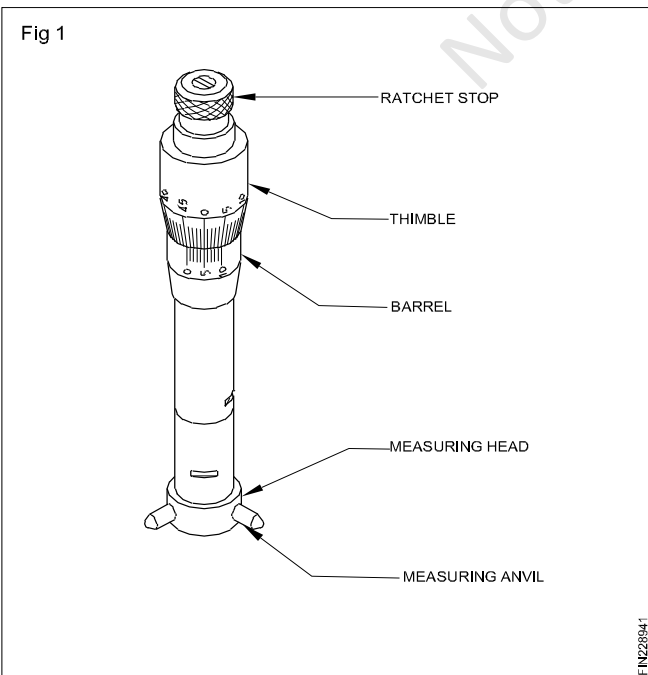

Three-point internal micrometers are available in different sizes permitting measurement within a range.

The ratchet stop permits uniform pressure between the anvils and the work-surface being measured.

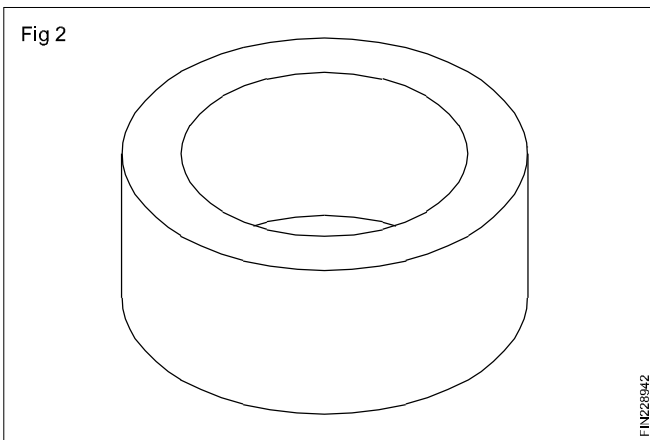

These micrometers are provided with one or more zero setting rings. (Fig 2)

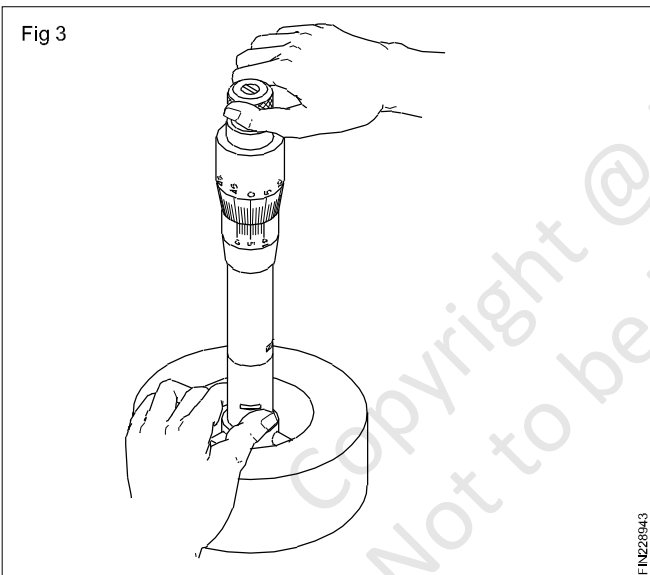

Before taking measurement, the zero setting has to be checked using setting ring. (Fig 3)

The position of the anvils can be reset by loosening the barrel using a screwdriver provided for this purpose.

Depending on the depth of the bore the length of the micrometer can be varied using an extension rod. (Fig 4)

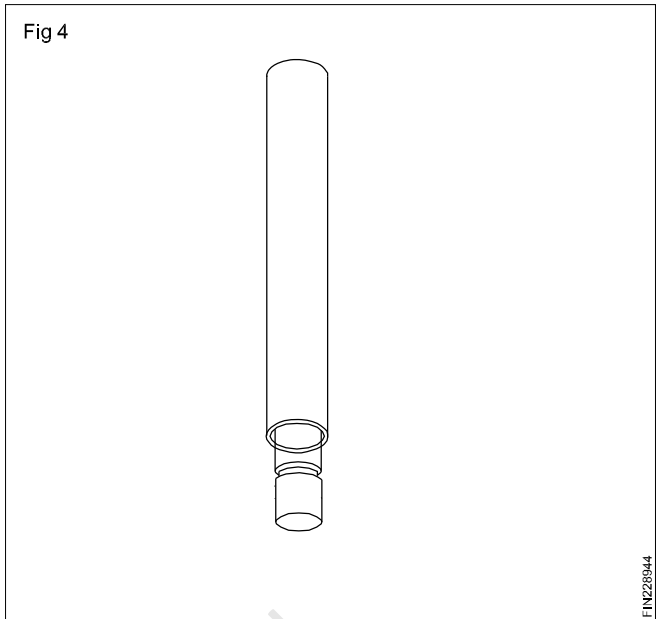

A spanner is provided for changing the extension rods. (Fig 5)

These instruments are available in various sizes for different uses.

They are also available in analogue or digital read-outs.

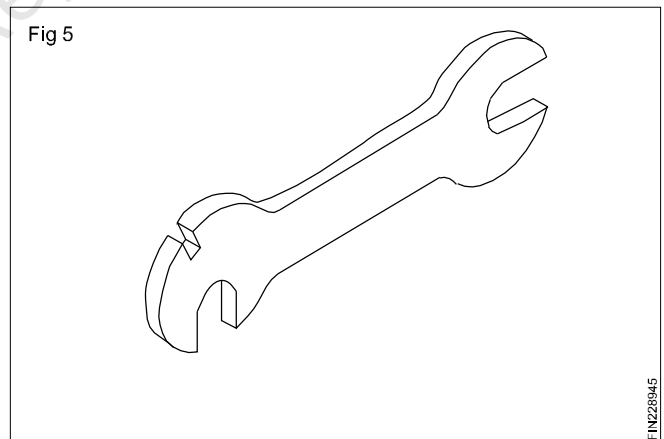

Safety to be observed while working on lathes

Objective: At the end of this lesson you shall be able to

- state the precautions to be observed before starting work on a lathe, during work and after.

Before starting the work

Ensure that the lubricating system is functioning.

The mating gears should be in proper mesh and the power feed levers are in neutral position.

The work area should be clean and tidy.

The safety guards should be in place.

During work

Never try to stop a rotating chuck with your hand. A rotating chuck is dangerous.

Switch off the machine before making any adjustment on the lathe.

It is dangerous to leave the chuck key in the chuck. Remove it immediately after use. (Fig 1)

Single point tools are sharp and dangerous. Be extra careful when using them.

Chips are sharp and dangerous. Never remove them with your bare hands. Use a chip rake or brush.

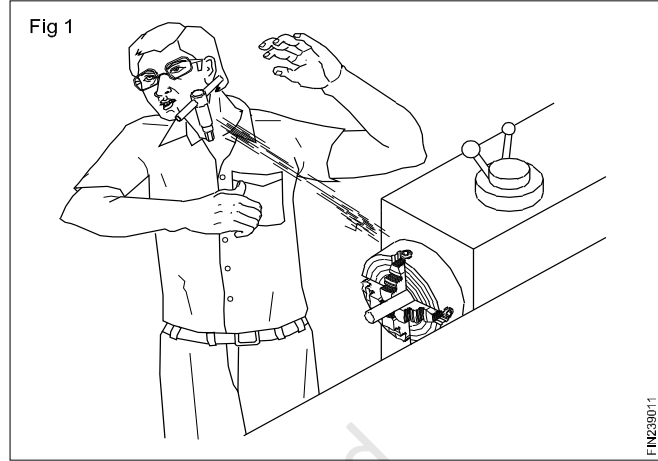

You must always know where the emergency stop switch is.

After work

Clean the lathe with a brush and wipe with cotton waste.

Oil the bedways and lubricating points.

Clean the surroundings of the lathe, wipe the dirt and coolant and remove the swarf.

Specification of a centre lathe

Objective: At the end of this lesson you shall be able to

- specify a centre lathe.

Specification of a lathe (Fig 1)

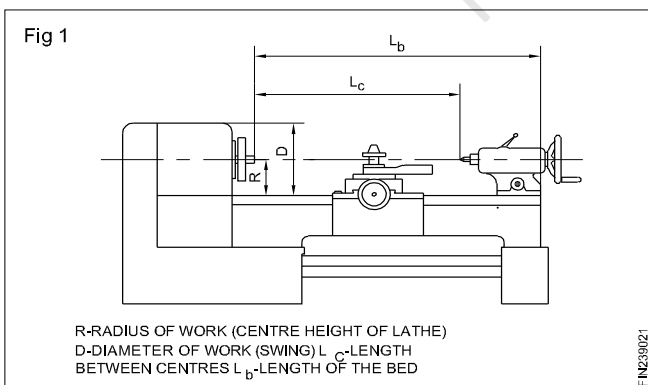

A lathe is to be specified by the following.

The maximum diameter of a work that can be held.

The swing over bed. This is the perpendicular distance from the lathe axis to the top of the bed.

The length of the bed. The length of the bed-ways.

The maximum length of work that can be turned between centres.

The range of threads that can be cut. The capacity of the lathe. The swing over carriage.

The value of each division on the graduated collars of the cross-slide and compound slide.

Range of spindle speeds.

Range of feeds.

Size of the spindle bore.

Type of spindle nose.

The specifications help in communication between the seller and the buyer of the lathe.

It helps the operator of the lathe to decide whether the work in hand can be accommodated for performing the operations.

Constructional features of lathe

Objectives: At the end of this lesson you shall be able to

- name the main parts of a lathe
- state the constructional features of lathe
- explain the principle of a lathe.

Centre lathe is a machine which is used to bring the raw material to the required shape and size by metal removal. This is done by feeding a cutting tool against the direction of rotation of the work.

The machine tool on which turning is carried out is known as a lathe.

Lathe is a machine tool which holds the job in between the centre and rotates the job on its own axis. Due to this quality of holding the job from the centre and rotating the job, it is called centre lathe. Work can be held on a chuck and face plate. Chuck and face plate are mounted on the front of spindle. Cutting tool is fed against work after holding it in the tool post firmly. The work rotates on its own axis and tool is moved parallel to work. When tool moves parallel

to axis it produces cylindrical surface and when it rotates at some angle, it produces taper surface.

Constructional features of a lathe

A lathe should have provision :

- To hold the cutting tool, and feed it against the direction of rotation.
- To have parts, fixed and sliding, to get a relative movement of the cutting tool with respect to the rotation of the work.
- To have accessories and attachments for performing different operations.

The following are the main parts of a lathe. (Fig 1)

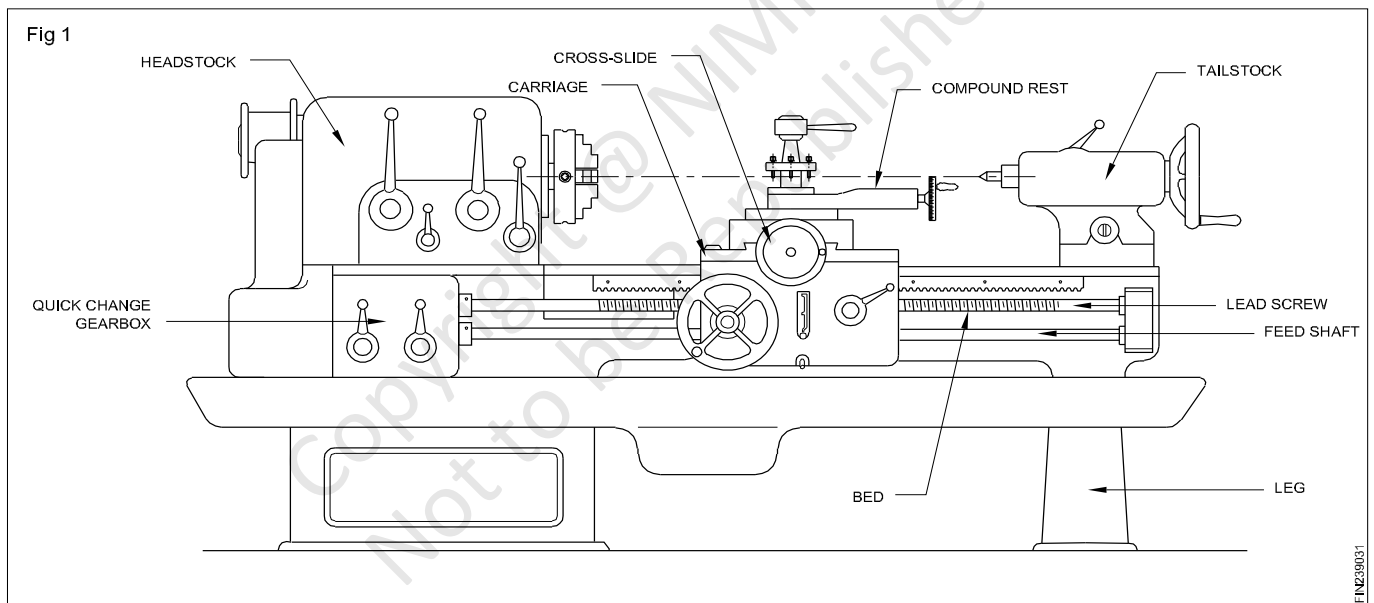

- Headstock
- Tailstock
- Carriage
- Cross-slide
- Compound slide
- Bed
- Quick change gearbox
- Legs
- Feed shaft
- Lead screw

Working principle of Lathe (Fig 2)

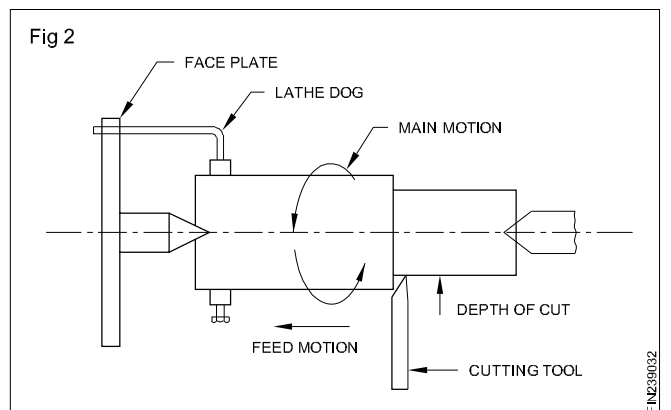

Lathe main parts

Objectives: At the end of this lesson you shall be able to

- name the parts
- state the functions of the parts

Lathe bed

Functions of a lathe bed

The functions of a lathe bed are:

- To locate the fixed units in accurate relationship to each other.
- To provide slide-ways upon which the operating units can be moved.

Constructional features of a lathe bed (Fig 1)

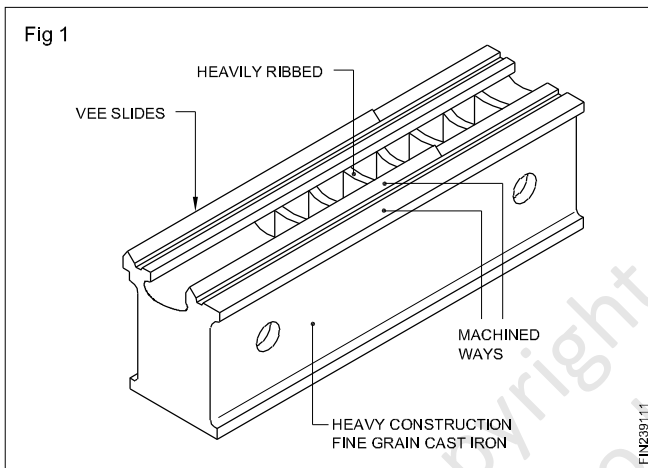

The lathe bed generally consists of a single casting. In larger machines, the bed may be in two or more sections accurately assembled together. Web bracings are employed to increase the rigidity. For absorbing shock and vibration, the beds are made heavy.

A combined swarf and coolant tray is provided on lathes. This may be an integral part with the lathe bed.

The bed is generally made by cast iron or welded sheet metal legs of box section. This provides the necessary working height for the lathe. Very often the electrical switch gear unit and the coolant pump assembly are housed in the box section of the legs at the headstock end.

Bed-ways (Fig 2)

The bed-ways or slideways assist in accurate location and sliding of the accessories/parts mounted on this.

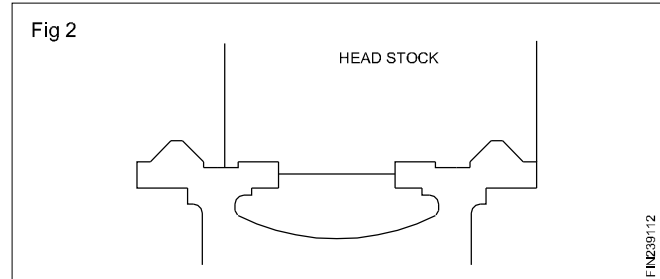

The bed-ways are of three types.

Flat bed-way (Fig 3)

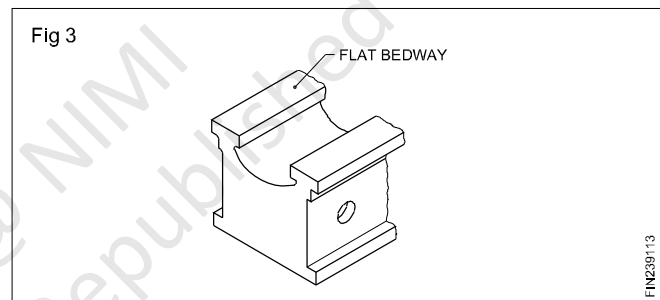

'V' bed way (Fig 4)

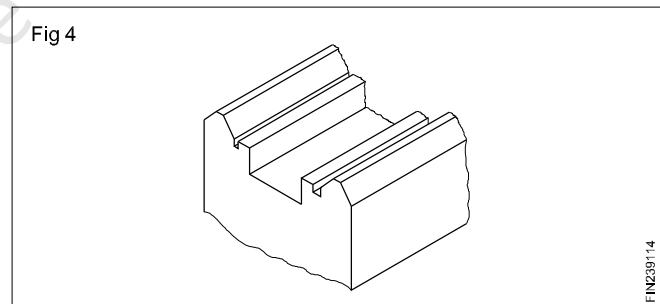

Combination bed way (Figs 5a & 5b)

Normally the bed-ways stop at a distance away from the headstock with a gap at this point. This enables to mount larger diameters of the work.

Some lathes have a detachable section of the bed, which can be fitted when desired, to enable the saddle to operate close to the headstock.

The bed-ways are highly finished by grinding. Some lathes have their bed-ways hand scraped. Some have their bed-ways hardened and ground. The wear-resisting qualities of bearing surfaces are improved by employing chilled iron castings.

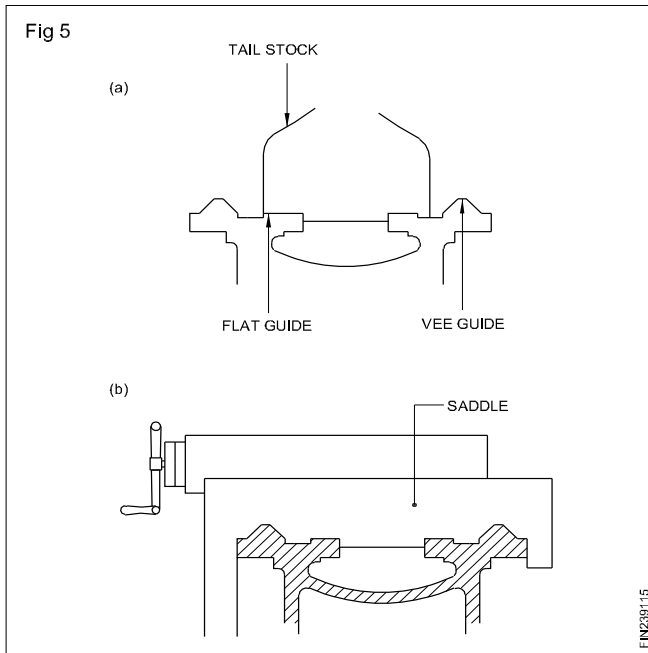

The beds are mostly made up of closely ground, grey cast iron.

Gap bedway (Fig 6)

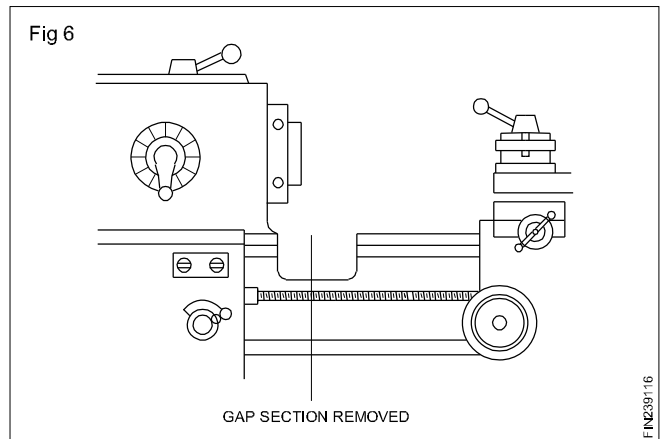

Headstock

Objectives: At the end of this lesson you shall be able to

- state the function of the headstock
- differentiate between cone pulley headstock and all geared headstock.

Functions (Fig 1)

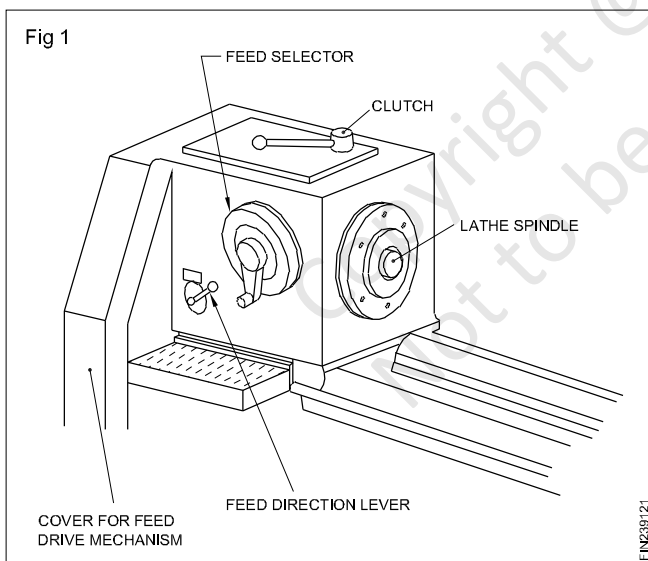

To provide a means to assemble the work-holding devices. Transmit the drive from the main motor to the work.

To accommodate shafts, gears and levers for a wide range of varying work speeds.

To ensure arrangement for lubricating the gears, shafts and bearings.

Types of headstocks

The following are the two types of headstocks.

- 1 All geared headstock.
- 2 Cone pulley headstock.

All geared headstock (Fig 2)

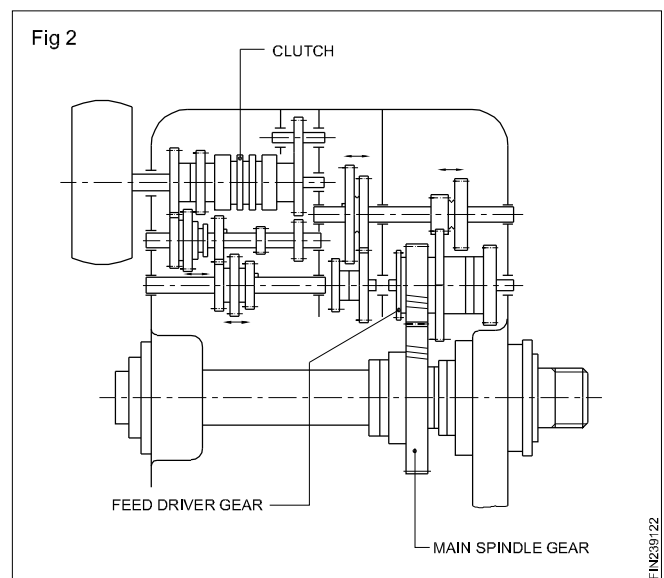

It is a box section casting having a removable top cover. It has internal webs for stiffening, and to take shaft bearings. It has an input shaft which is connected by means of 'V' belts to the main motor, and it runs at a constant speed. It is equipped with clutches and a brake.

There may be two or more intermediate shafts on which sliding gears are mounted. The main spindle is the last driven shaft in the headstock assembly. The nose of the spindle is outside the headstock casting, and is designed to accommodate the work-holding devices.

The levers operating the forks for the sliding gears are situated outside in front of the headstock casting.

In the all-g geared headstock, lubricating oil is filled for splash lubrication of the internal gears. A sight glass with an oil level mark is provided to see the oil level.

Cone pulley headstock (Fig 3)

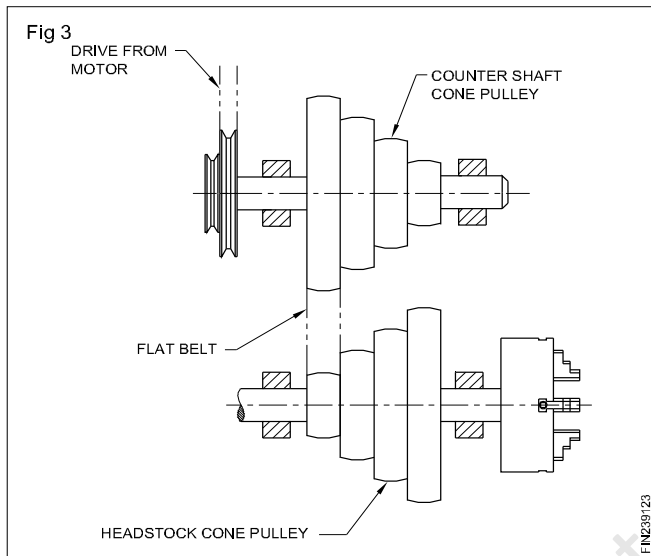

It has a stepped cone pulley mounted on the main spindle, and it is free to revolve. It is connected by means of a flat belt to a similar cone pulley, with steps arranged in the reverse order. This cone pulley gets the drive from the main motor.

The spindle is mounted on the bearing on the headstock casting and has a gear wheel called 'bull gear' keyed to it. A pinion is coupled to the cone pulley.

The back gear unit has a shaft which carries a gear and a pinion. The number of teeth of the gear and pinion on the back gear shaft corresponds to the number of teeth on the bull gear and pinion on the cone pulley. The axis of the

back gear shaft is parallel to the axis of the main spindle. The back gear is engaged or disengaged with the cone pulley system by means of a lever. The back gear unit is engaged for reducing the spindle speeds. (Fig 4)

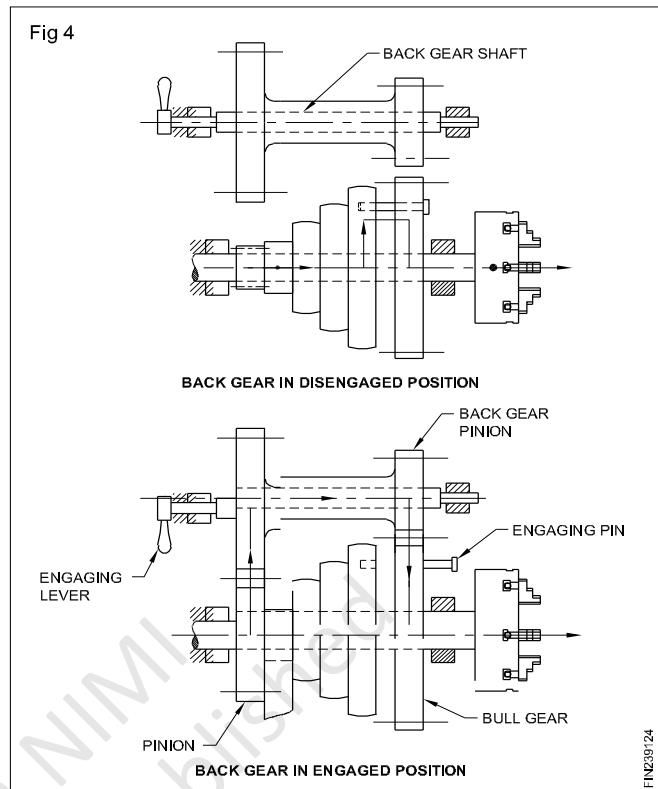

A three-stepped cone pulley headstock provides 3 direct ranges of speeds through a belt connection. With the back gear in engagement, 3 further ranges of reduced speeds can be obtained.

Advantages

- Can take up heavy load.
- Less noise during working.
- Easy to maintain.

Disadvantages

- The number of spindle speeds is limited to the number of steps in the cone pulley.
- It takes time to change the spindle speeds.

Carriage

Objectives: At the end of this lesson you shall be able to

- state the functions of a carriage
- name the parts of a carriage.

Carriage is the feature of a lathe that provides the method of holding and moving the cutting tool. (Fig 1) It can be locked at any desired position on the lathe bed. It consists of two major parts namely, apron and saddle.

Apron (Fig 2)

The apron is bolted to the front of the saddle. It contains mechanism for moving and controlling the carriage. The main parts of an apron are :

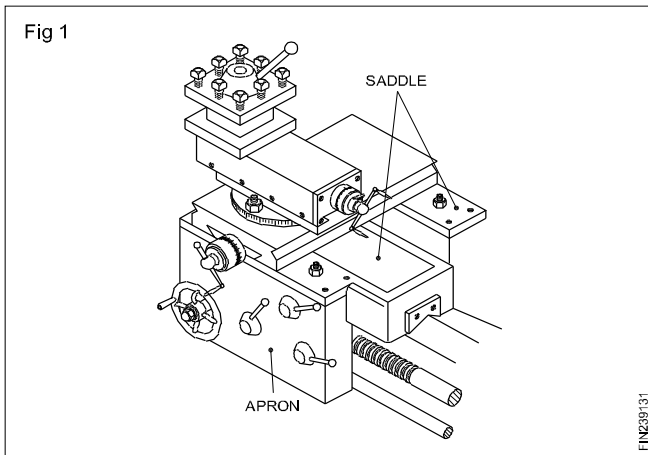

It is a 'H' shaped casting having 'V' guide grooves at the bottom face, corresponding to the lathe bed-ways for mounting on the lathe bed and for sliding.

Parts of a saddle

Cross-slide

The cross-slide is mounted on the top of the saddle, and it provides cross movement for the tool. This is fitted at right angles to the bed and is moved by means of a screwed spindle, fitted with a handle. A graduated collar, mounted on the screw rod along with the hand wheel, helps to set the fine movements of the cross- slide.

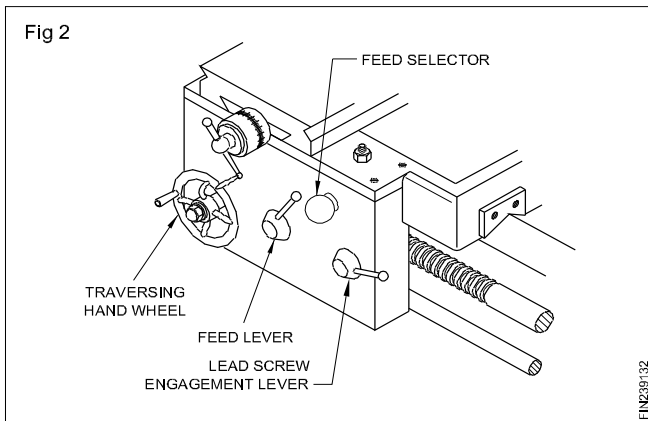

Compound rest

The compound rest is fitted on the top and to the front of the cross-slide. The compound rest can be swivelled horizontally through 360°.

Top slide

The top slide is fitted on the top of the compound rest. It supports the tool post which holds the cutting tool. The top slide provides a limited horizontal movement for the cutting tool.

- Traversing hand wheel
- Feed lever
- Feed selector
- Lead screw engagement lever.

By swivelling the compound rest, the top slide can be set at an angle to the cross-slide (Fig 4). Usually the compound rest is set in such a way that the top slide is at right angles to the cross-slide.

Saddle (Fig 3)

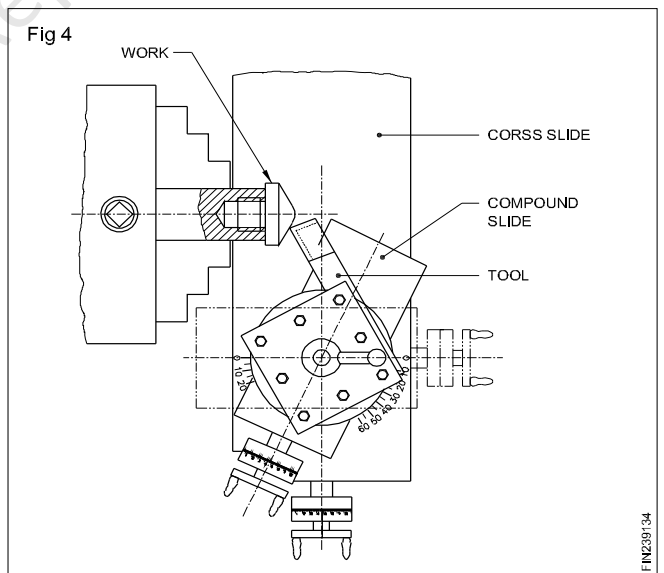
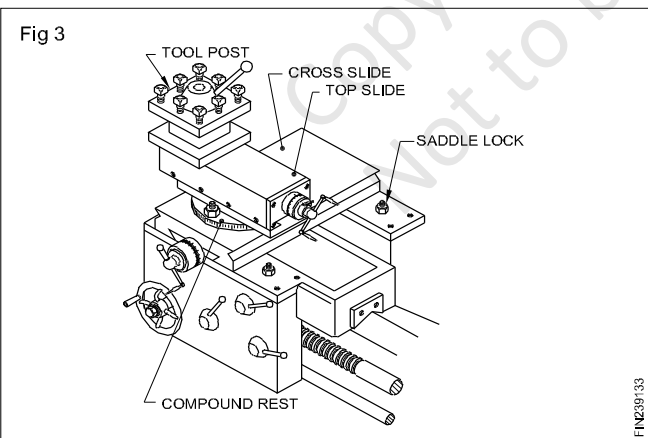

Tailstock

Objectives: At the end of this lesson you shall be able to

- list the parts of a tailstock
- state the uses of a tailstock
- explain the function of a tailstock.

Tailstock

It is a sliding unit on the bed-ways of the lathe bed. It is situated on the right hand side of the lathe. It is made in two parts namely the 'base' and the 'body'. The base bottom is machined accurately and has 'V' grooves corresponding to the bed-ways. It can slide over the bed and can be clamped at any position on the bed by means of the clamping unit. The body of the tailstock is assembled to the base. Graduations are marked on the rear end of the base and a zero line is marked on the body.

When both zero lines coincide, the axis of the tailstock is in line with the axis of headstock.

The body and base are made out of cast iron. The parts of a tailstock are: (Fig 1)

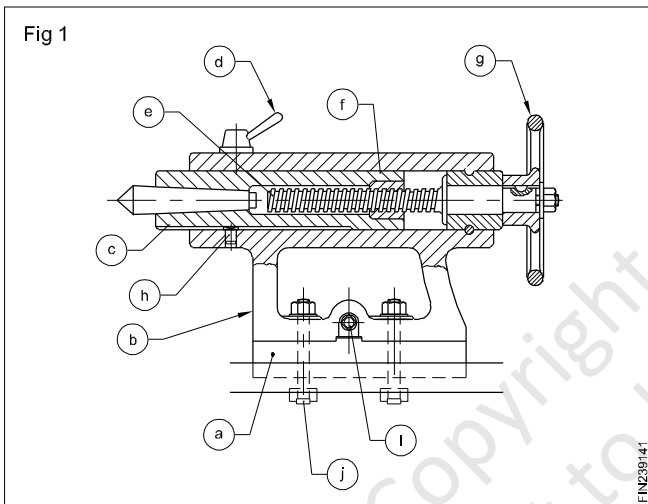

- a Base
- b Body
- c Spindle (barrel)
- d Spindle locking lever
- e Operating screw rod
- f Operating nut
- g Tailstock hand wheel
- h Key
- i Set screw/set overscrew
- j Clamping bolt

Functioning of a tailstock

By rotating the hand wheel, the barrel can be moved forward or backward. The barrel can be locked in any required position. The hollow end of the barrel at the front is provided with a Morse taper to accommodate the cutting tools with a taper shank. Graduations are sometimes marked on the barrel to indicate the movement of the barrel. With the help of the adjusting screws, the body can be moved over the base laterally, and the amount of movement may be read approximately referring to the graduations marked. This arrangement is to offset the centre of the tailstock as required for taper turning.

Purpose of the tailstock

To accommodate the dead center to support lengthy work to carry out lathe operations. (Fig 2)

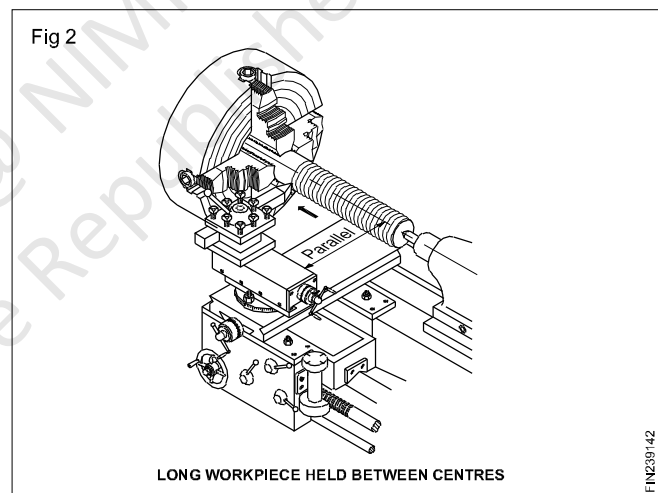

To hold cutting tools like drills, reamers, drill chucks provided with taper shank. (Fig 3)

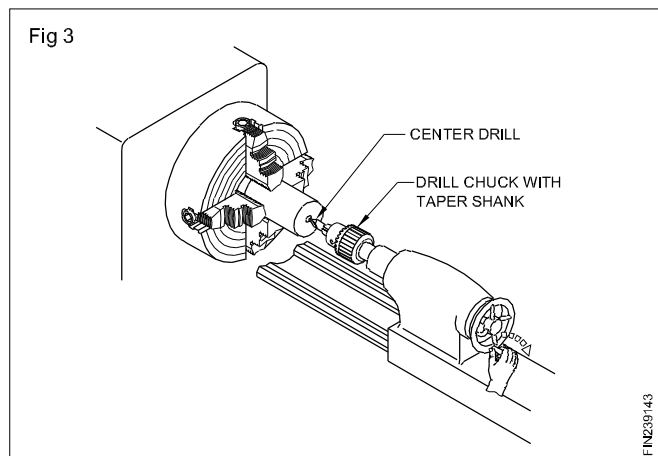

To turn external taper by offsetting the body of the tailstock with respect to the base. (Fig 4)

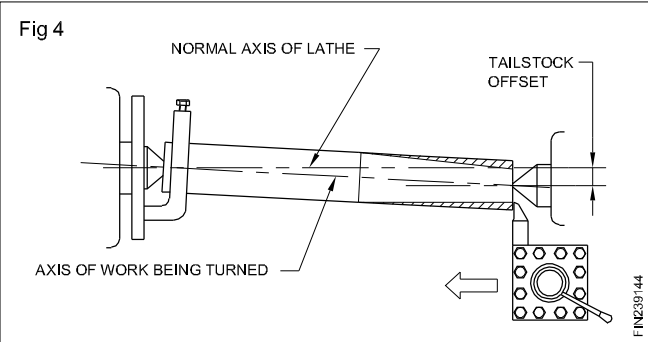

Copyright @ NIMI
Not to be Republished

Feeding & thread cutting mechanism

Objectives: At the end of this lesson you shall be able to

- name the parts of the feeding mechanism
- state the functional features of the feeding mechanism.

Feed mechanism (Fig 1)

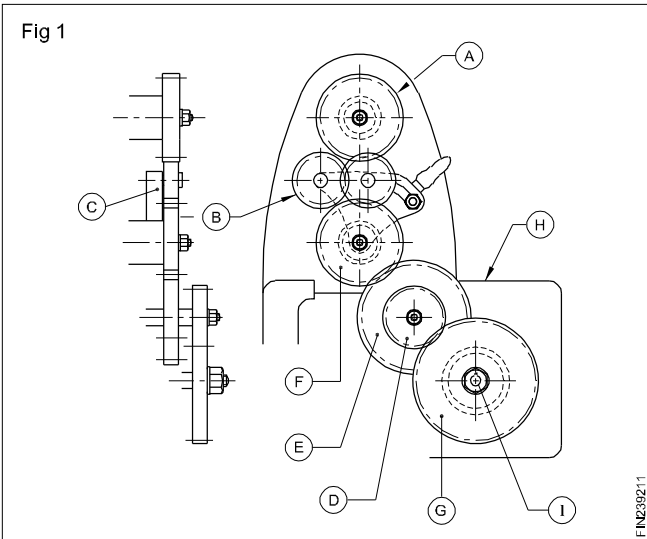

The feed mechanism of a lathe enables automatic feeding for the tool longitudinally and transversely as needed. By automatic feeding the finish on the work will be better, the feeding of the tool will be at a uniform continuous rate and it takes less time to finish the operation while manual labour is avoided.

The feed mechanism comprises the following.

- Spindle gear (A)
- Tumbler gear unit (B)
- Fixed stud gear (C)
- Change gear unit (DEFG)
- Quick change gear box (H)
- Feed shaft / Lead screw (I)
- Apron mechanism (Fig 5)

The proportionate tool movement for each revolution of work is achieved through all the above units of the feed mechanism.

Spindle gear

The spindle gear is fitted to the main spindle, and it is outside the headstock casting. It revolves along with the main spindle.

Tumbler gear unit

The tumbler gear unit set of three gears, having the same number of teeth and it connects the spindle gear to the fixed gear. It is also called the reversing gear unit as it is used to change the direction of feed of the tool for the same direction of rotation of the spindle. It can be engaged and disengaged with the fixed stud gear by the operation of the hand lever provided in the unit. (Fig 2)

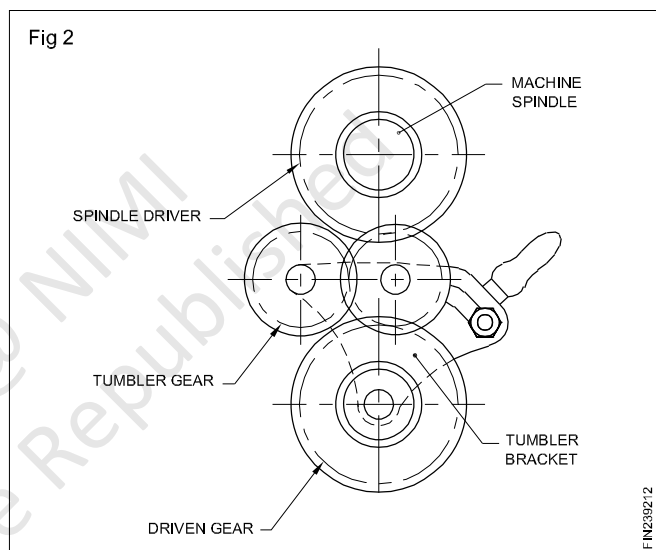

The fixed stud gear

The fixed stud gear gets the drive from the main spindle gear through the tumbler gear unit and runs at the same number of revolutions per minute as the spindle gear on most lathes.

Change gear unit

The fixed stud gear transmits its drive through a change gear unit to the quick change gear box. The change gear unit has provision for changing the driver, the driven and the idler gears from the set of change gears available for the purpose of feed changing as an additional unit. (Fig 3)

Quick change gear box

The quick change gear box is provided with levers outside the box casting, and by shifting the levers, different gears are brought in mesh so that different feed rates can be given to the tool. A chart listing the different feed rates for the different positions of the levers is fixed to the casting, and by referring to the table, the levers may be engaged in position for the required feed rate. (Fig 4)

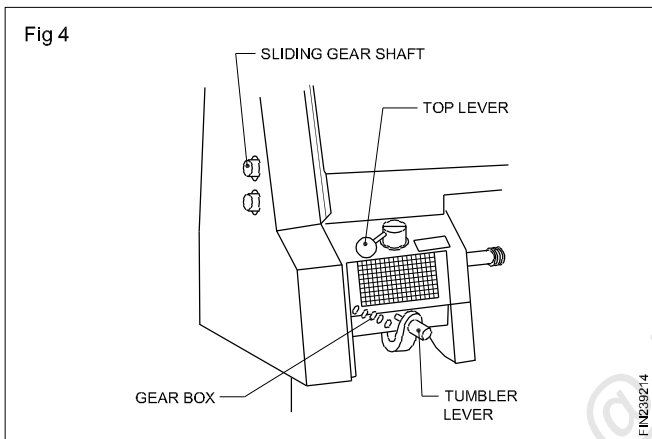
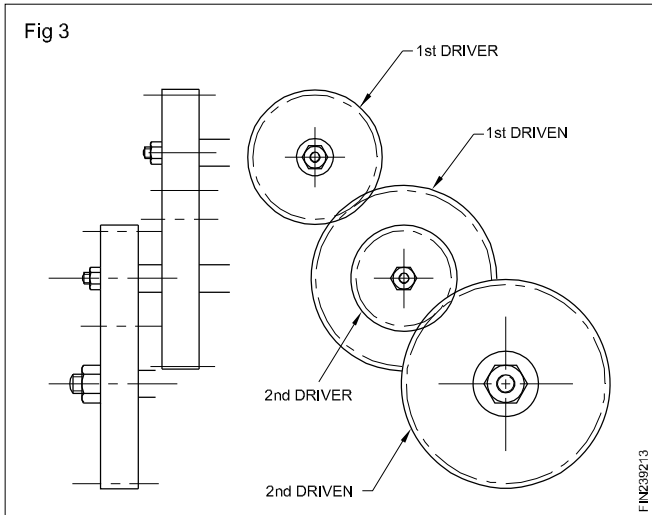

The feed shaft

The feed shaft gets its drive from the quick change gear box, and through the apron mechanism, the rotary movement of the feed shaft is converted into the linear movement of the tool.

The apron mechanism

The apron mechanism has the arrangement for transmitting the drive from the feed shaft to the saddle for longitudinal movement of the tool or to the cross-slide for the transverse movement of the tool. (Fig 5)

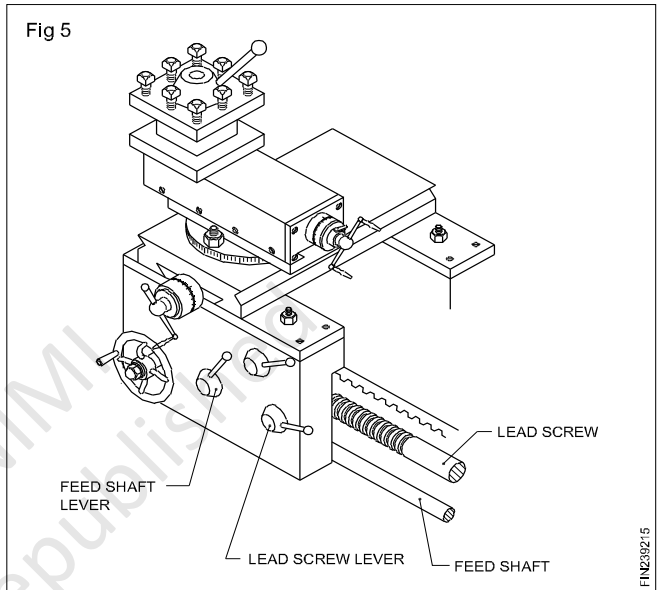

Thread cutting with simple and compound gear trains

Objective: At the end of this lesson you shall be able to

- thread cutting with simple and compound gear trains.

Change gear train

Change gear train is a train of gears serving the purpose of connecting the fixed stud gear to the quick change gearbox. The lathe is generally supplied with a set of gears which can be utilized to have a different ratio of motion between the spindle and the lead screw during thread cutting. The gears which are utilized for this purpose comprise the change gear train.

The change gear train consists of driver and driven gears and idler gears.

Simple gear train

A simple gear train is a change gear train having only one driver and one driven wheel. Between the driver and the driven wheel, there may be an idler gear which does not affect the gear ratio. Its purpose is just to link the driver and the driven gears, as well as to get the desired direction to the driven wheel.

Fig 1 shows an arrangement of a simple gear train.

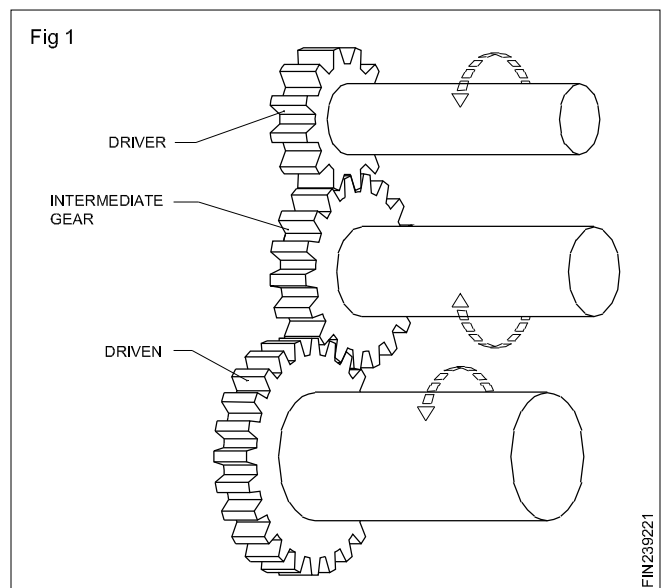
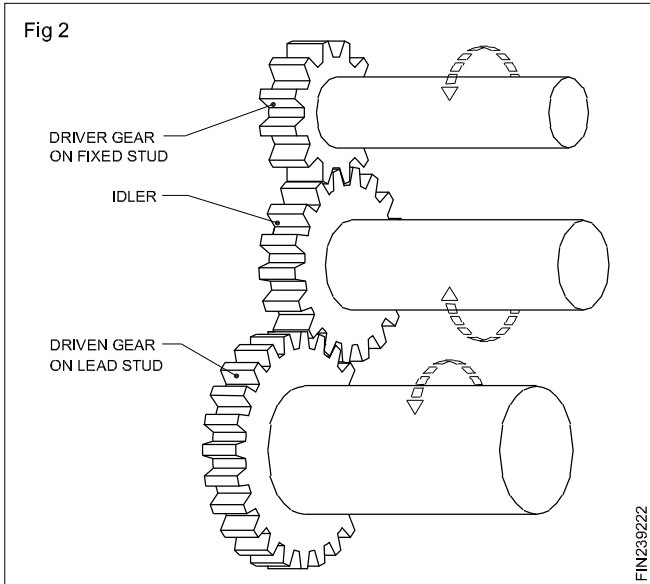

Fig 2 shows mountings of the driver and driven gears in a lathe.



The driver gear and the driven gear are changed according to the pitch of the thread to be cut on the job.

Compound gear train

Sometimes, for the required ratio of motion between the spindle and the lead screw, it is not possible to obtain one driver and one driven wheel. The ratio is split up and then the change gears are obtained from the available set of gears which will result in having more than one driver and one driven wheel. Such a change gear train is called a compound gear train.

Fig 3 shows the arrangement of a compound gear train.

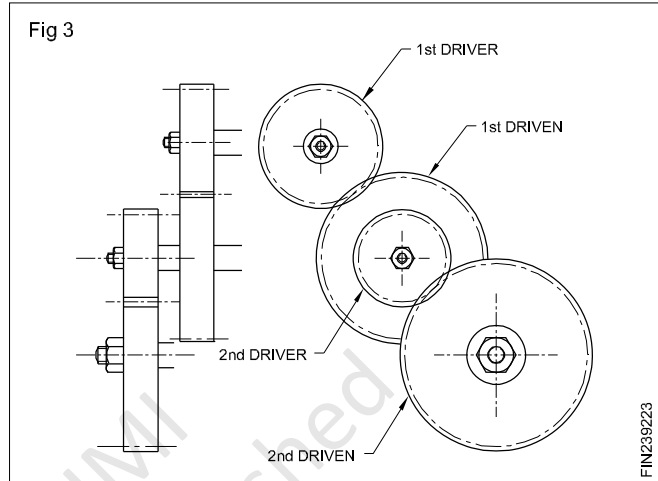

Holding the job between centre and work with catch plate and dog

- Objectives:** At the end of this lesson you shall be able to
- preparing work for turning between centre
 - to set the catch plate
 - working with catch plate and dog

Turning work in-between centres avoids the need for truing the work. The work turned will be parallel through-out. But it requires great skill to perform operations especially like knurling, thread cutting, undercutting. It is limited to external operations only. The work needs the following preparations to be carried out before the actual operations are to be performed.

Face both sides of the work, and maintain the total length accurately within limits.

Choose the correct size and type of centre drill and do centre drilling at both ends.

Diamantle the chuck from the spindle nose and assemble the driving plate or catch plate.

Assemble the spindle sleeve to the spindle nose and fix live centre to the sleeve.

Ensure that the spindle sleeve and live centre are free from damages, burrs and are thoroughly cleaned before assembly.

Check for the true running of the live centre. (Fig 1)

Select a suitable lathe carrier according to the diameter of the work and fasten it on one end of the work with the bent tail pointing outwards. (Fig 2)

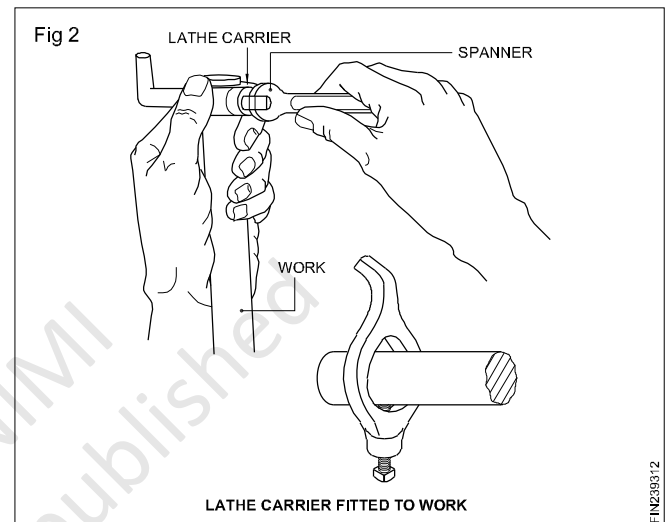

Work that has a finished surface should be protected by inserting a small sheet of copper or brass between the end of the screw in the carrier and the work. (Fig 3)

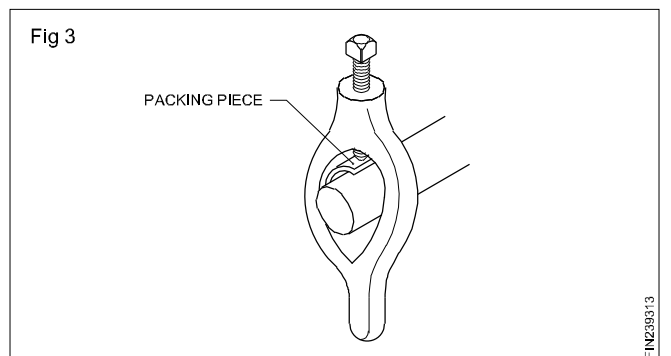

Apply a suitable lubricant (soft grease) to the centre hole of the workpiece to be engaged by the tailstock dead centre.

Move the tailstock to a position on the bed to suit the length of the workpiece. The tailstock spindle should extend approximately 60 to 100 mm beyond the tailstock.

Ensure there is sufficient space for the saddle to operate before clamping the tailstock to the bed.

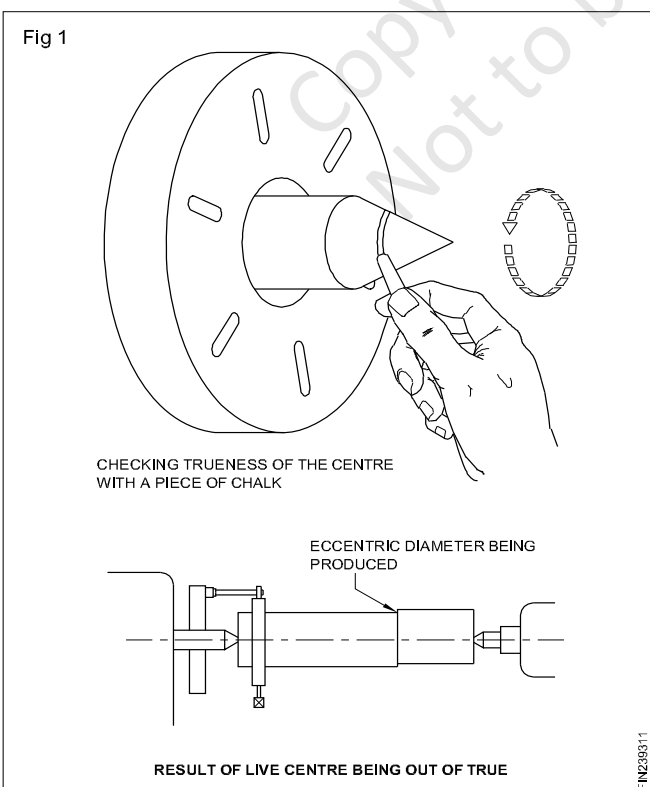

Clamp the tailstock in position by tightening the tailstock clamp nut. (Fig 4)

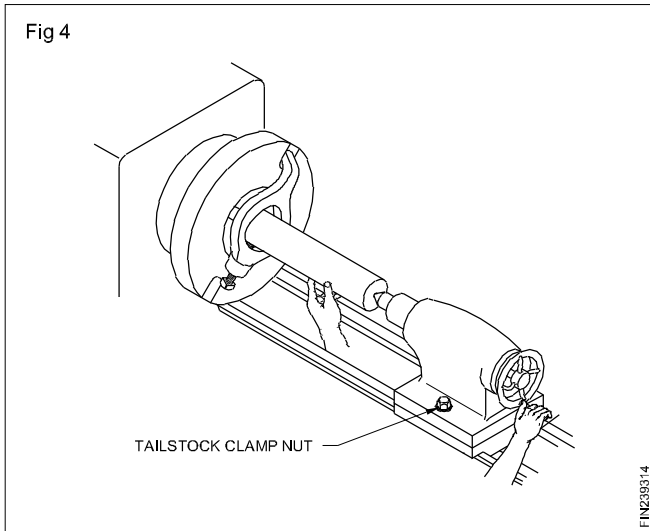

Engage the work-centre hole with the point of live centre and with the tail of the lathe carrier in the slot in the catch plate. Hold the work in this position with hand.

Ensure that the tail of the lathe carrier does not rest on the bottom of the slot in the driving plate. This will not permit the centre entering the centre hole of the work for proper seating. (Fig 5)

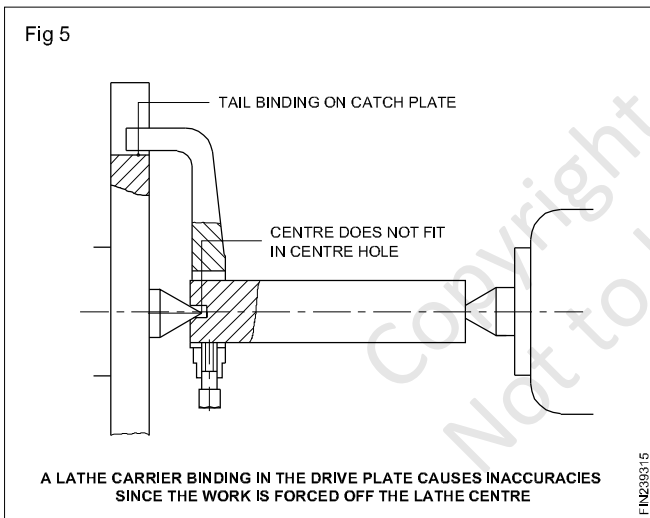

Advance the tailstock spindle by the hand wheel rotation until the point of dead centre enters the centre hole of the work with proper seating eliminating all endwise movement. (Fig 6)

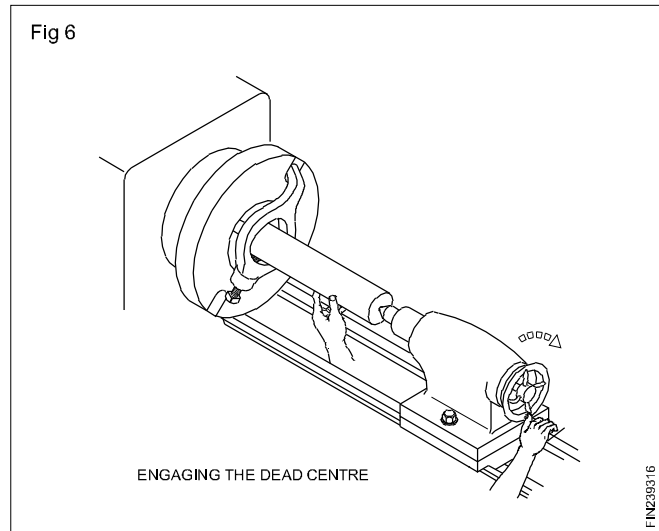

Move the tail of the carrier back and forth. At the same time adjust the hand wheel until only a slight resistance is felt.

Tighten the tailstock spindle clamp at this position and check that the resistance does not change. Set the machine for about 250 r.p.m. and allow the work to run for a few seconds.

Check once again for the resistance and adjust the tailstock spindle, if needed.

Work is now ready for operations. (Fig 7)

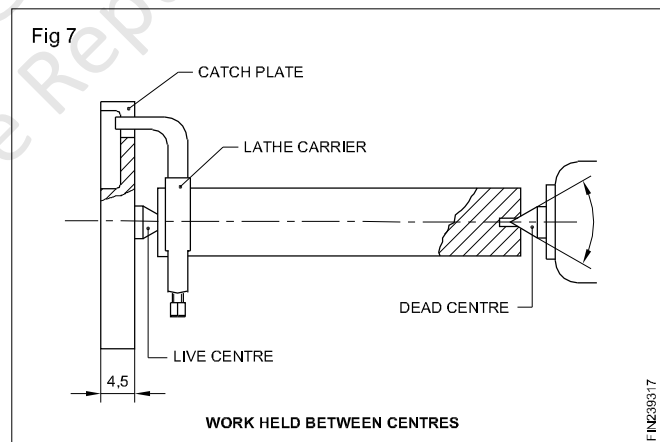

Before holding the work in between centres ensure that the centres are aligned.

Simple description of facing and roughing tool

Objectives: At the end of this lesson you shall be able to

- state the purpose of facing
- setting the rough facing tool
- state the reasons for the defects
- state the remedies to overcome the defects in facing

Facing

This is an operation of removing metal from the work-face by feeding the tool at right angles to the axis of the work. (Fig 1)

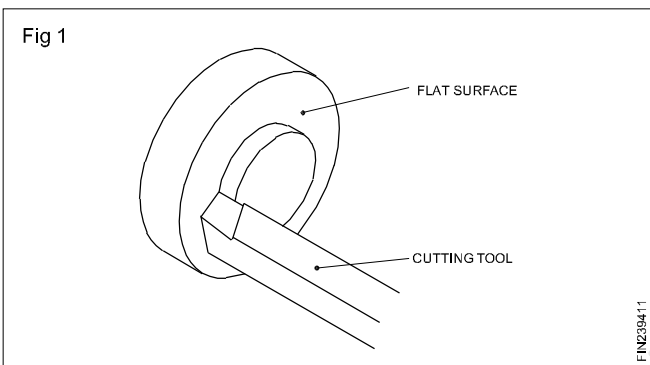

Purpose of facing

- To have a reference plane to mark and measure the step lengths of the work.
- To have a face at right angle to the axis of the work.
- To remove the rough surface on the faces of the work and have finished faces instead.
- To maintain the total length of the work.

Facing may be rough or finish facing. Rough facing is done to remove the excess metal on the face of the work by coarse feeding with more depth of cut, leaving sufficient metal for finishing. Rough facing is done by feeding the tool from the periphery of work towards the centre of the work. Finish facing is the operation to have a smooth face by removing the rough surface produced by the rough facing.

Finish facing is done by feeding the tool from the centre of the work towards the periphery. (Figs 2a and 2b)

Rough facing is done by choosing a spindle RPM according to the average diameter of the work, the recommended cutting speed, with a coarse feed and more depth of cut.

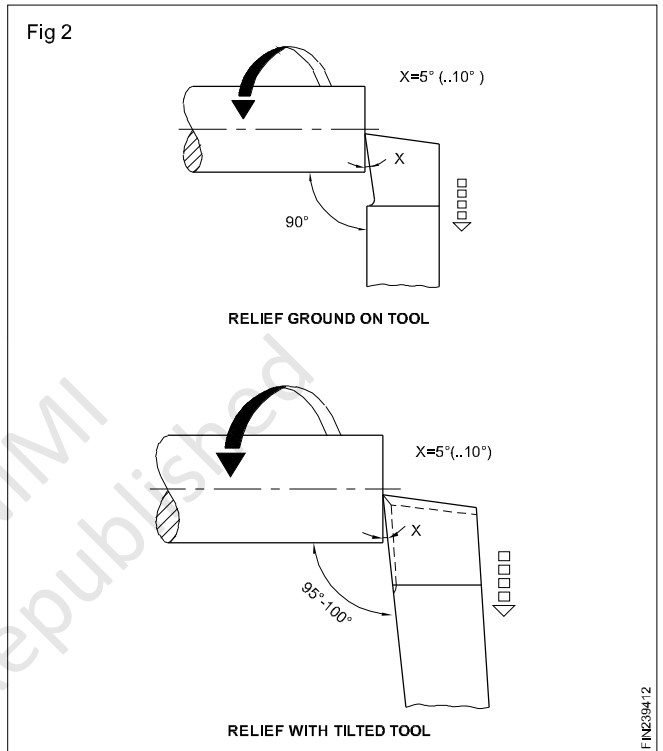

Finish facing is done by choosing a cutting speed about twice that of the cutting speed for roughing, with a fine feed rate of 0.05 mm approximately and with a depth of cut of not more than 0.1 mm.

The following are the defects found in facing work (Fig 3)

A concave face

This is caused by the tool digging into the work during the feeding as the tool is not clamped rigidly. By clamping the tool rigidly with minimum overhang, this defect can be avoided.

A convex face

This is caused by the blunt cutting edge of the tool and the carriage not being locked. To avoid this defect, re-sharpen the tool and use it; Also lock the carriage to the bed of the lathe.

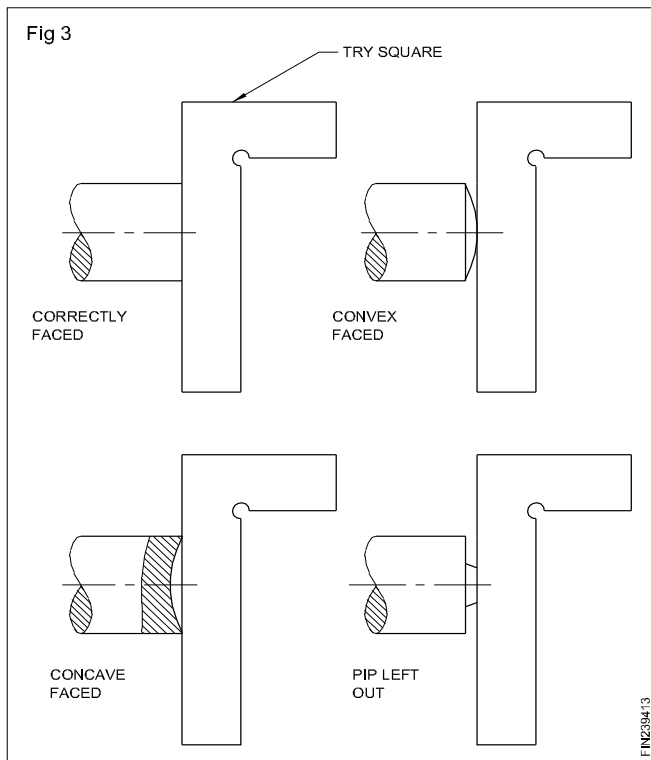

A pip left in the centre

This is due to the tool not being set to the correct centre height. By placing the tool to the centre height, this defect can be avoided.

Copyright @ NIMI
Not to be Republished

Nomenclature of single point cutting tools and multi point cutting tools

Objectives: At the end of this lesson you shall be able to

- name the types of cutting tool
- state the nomenclature of single point cutting tools
- state the nomenclature of multi point cutting tools

Lathe cutting tools are divided into two groups. These are

- 1 Single point cutting tools
- 2 Multi point cutting tools

Single point cutting tool nomenclature

The tool acts like a wedge during turning. The wedge shaped cutting edge penetrates into the work and removes the metal. This necessitates the grinding of a tool cutting edge to a wedge shape.

When we sharpen a pencil with a pen knife by trial and error, we find that the knife must be presented to the wood at a definite angle, if success is to be achieved. (Fig 1)

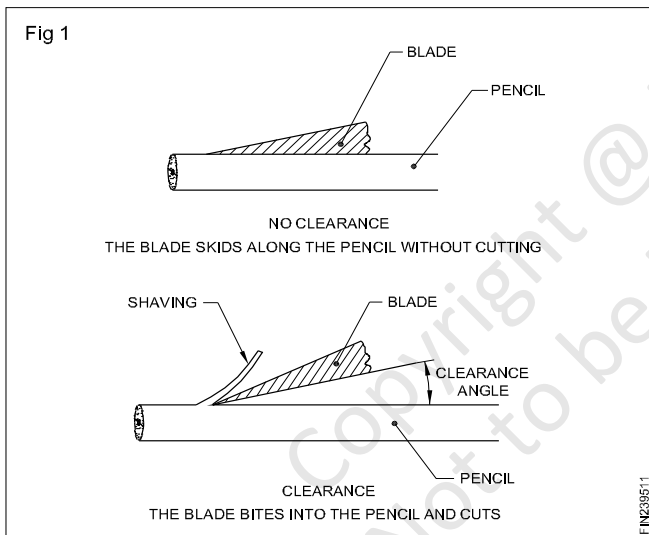

If, in the place of a wooden pencil, a piece of soft metal such as brass is cut, it will be found that the cutting edge of the blade soon becomes blunt, and the cutting edge gets crumbled. For the blade to cut the brass successfully, the cutting edge must be ground to a less acute angle. (Fig 2)

The angle shown in Fig 1 is called as clearance angle and that shown in Fig 2 is a wedge angle.

Angles ground on a lathe cutting tool (Fig 3)

All the angles given below may not be located or found in every tool. As an example a roughing tool is chosen. The angles and clearances ground on this tool are:

- 1 Approach angle
- 2 Trail angle
- 3 Top rake angle

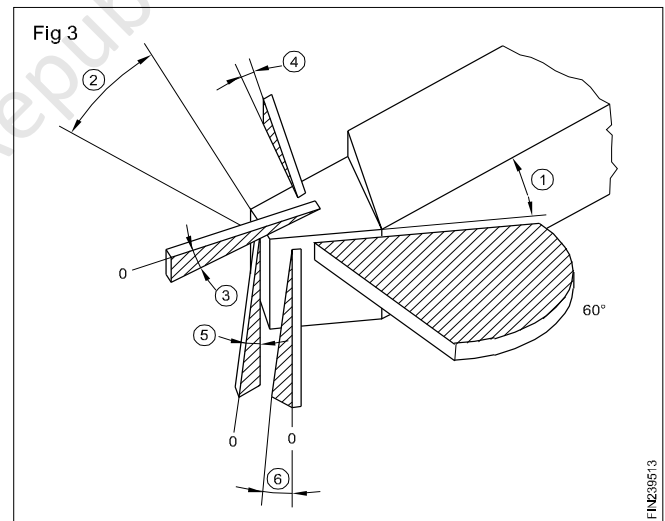
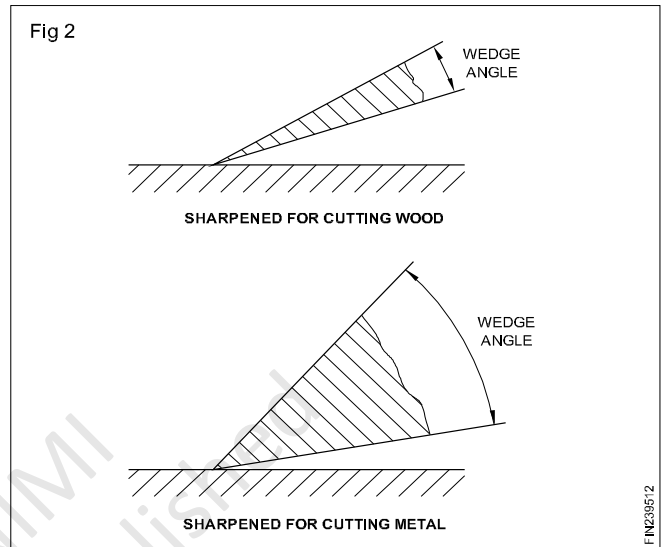

- 4 Side rake angle
- 5 Front clearance angle
- 6 Side clearance angle

Multi point cutting tools used in lathe are:

- Drill RT for Ex.No. 2.1.61
- Reamer RT for Ex.No. 2.1.67
- Tap RT for Ex.No. 2.1.70
- Die RT for Ex.No.2.1.71

Hand chasers and their uses

Objectives: At the end of this lesson you shall be able to

- state what is a hand chaser
- state the constructional features of a hand chaser
- state the uses of a hand chaser.

It is not possible to cut a full thread form with a single point cutting tool as errors like improper crest flat, root radius and profile etc are likely to occur. The same may be corrected by using a tool known as a chaser. (Fig 1)

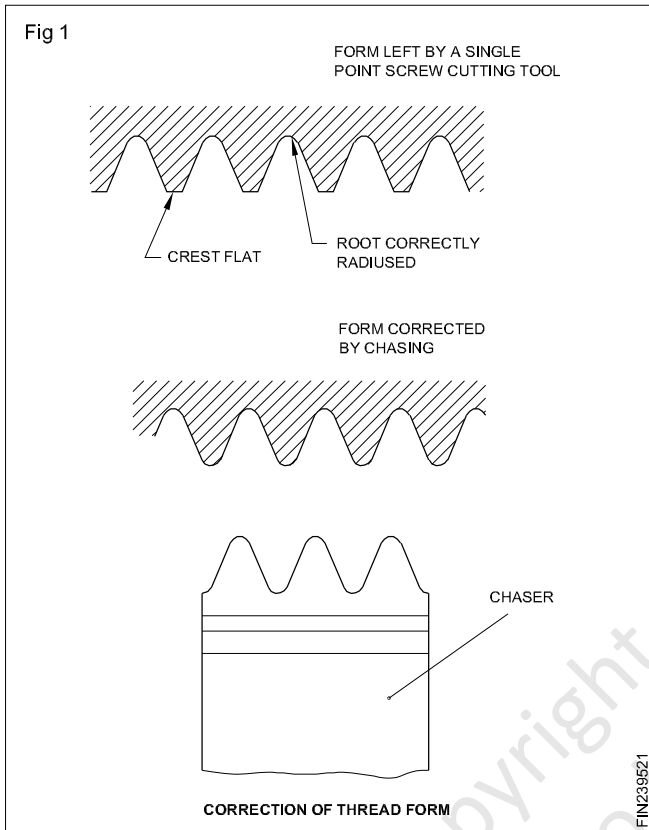

Hand chasers

Hand chasers are the devices which are used to remove less amount of material at the time of correcting and finishing a thread.

There are two types of hand chasers.

- External thread chasers Fig 2

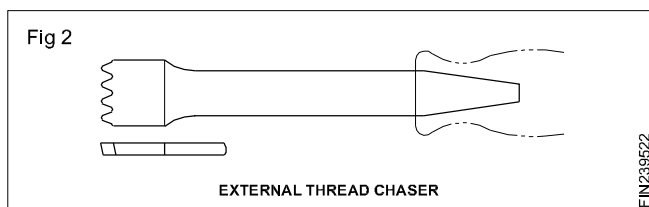

- Internal thread chasers Fig 3

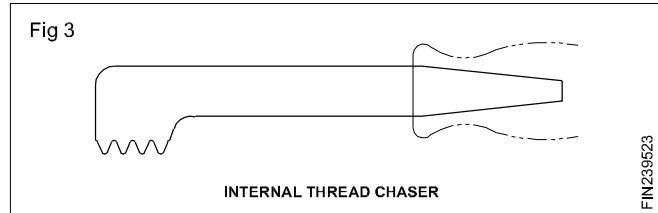

Constructional features

They are made up of a rectangular cross-section of tool steel, hardened and tempered, and ground to correct size. At the front, multi-point cutting teeth are formed with a proper rake angle. On the other end it is narrower to fix the handle. The teeth pitch corresponds to the thread pitch on the work to be finished. The chasing rest must be kept close up to the workpiece, so that the chaser cannot be dragged down between the rest and the workpiece. (Fig 4)

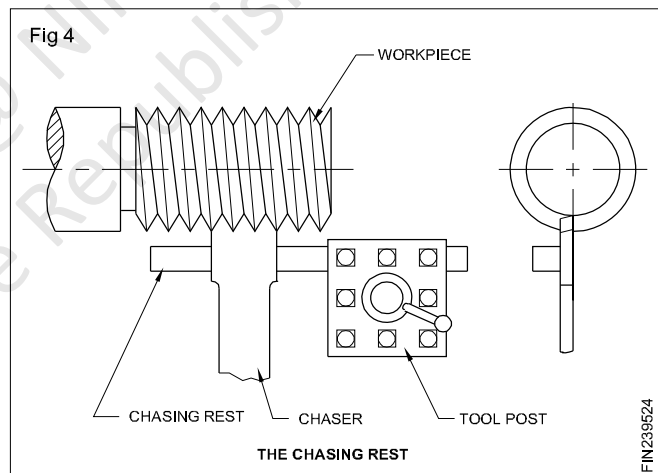

When chasing, the thread is cut slightly oversize, then trimmed down to size with the chaser; constantly check the thread with a thread ring gauge, if necessary.

Alternatively, a full thread may be cut from the solid, using a circular form tool. The form on the tool is slightly modified to allow for the distortion caused by the rake angle, so that the true form is cut. Such form tools are very expensive compared to a single point tool, and care must be taken not to chip them by incorrect usage. (Fig 5)

A button die held in a die-holder and mounted in the tailstock may also be used to finish threads to size and even cut them from the solid when threading low strength materials. (Fig 6)

Fig 5

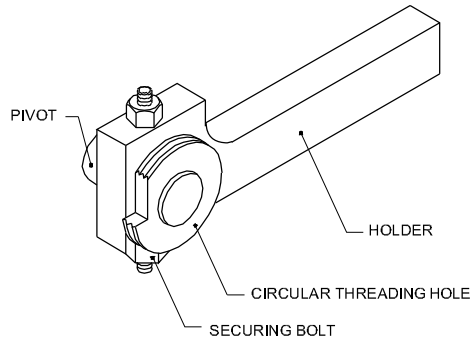

FIN239525

Fig 6

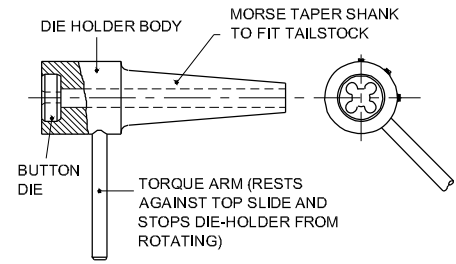

FIN239526

Copyright @ NIMI
Not to be Republished

Tool selection based on different requirements

Objectives: At the end of this lesson you shall be able to

- state the qualities of good cutting tool material
 - state the factors to be remembered when selecting tool
 - name the different types of tool
 - name the shapes of the tool
-

Cutting tool materials

Tool materials should be:

- Harder and stronger than the material being cut
- Tough to resist shock loads
- Resistant to abrasion thus contributing to long tool life.

Cutting tool material should possess the following qualities.

- Cold hardness
- Red hardness
- Toughness

Cold hardness

It is the amount of hardness possessed by a material at normal temperature. Hardness is the property by which it can cut/scratch other metals. When hardness increases, brittleness also increases, and a material, which has too much of cold hardness, is not suitable for the manufacture of cutting tools.

Red hardness

It is the ability of a tool material to retain most of its cold hardness property even at very high temperatures. While machining, the friction between the tool and the work, the tool and the chips, causes heat to be generated, and the tool loses its hardness, and its efficiency to cut diminishes. If a tool maintains its cutting efficiency even at increased temperatures during cutting, it can be said that it possesses the red hardness property.

Toughness

The property to resist breakage due to sudden load that results during metal cutting is termed as 'toughness' This will reduce the breakage of the cutting edges of tools.

The following factors are to be considered, when selecting a tool material.

- Material to be machined.
- Condition of the machine tool.(rigidity and efficiency)

- The total quantity of production and the rate of production.
- The dimensional accuracy required and the quality of surface finish.
- The amount of coolant applied and method of application.
- Condition and form of material to be machined.

Grouping of tool material

The three groups under which tool materials fall are:

- ferrous tool materials
- non-ferrous tool materials
- non-metallic tool materials.

Ferrous tool materials

These materials have iron as their chief constituent. High carbon steel (tool steel) and high speed steel belong to this group.

Non-ferrous tool materials

These do not have iron, and they are formed by alloying elements like tungsten, vanadium and molybdenum. Stellite belongs to this group.

Carbides

These materials are also non-ferrous. They are manufactured by powder metallurgy technique. Carbon and tungsten are the chief alloying elements.

Non-metallic materials

These tool materials are made out of non metals. Ceramics and diamonds belong to this group.

High carbon steel is the first tool material introduced for manufacturing cutting tools. It has poor red hardness property, and it loses its cutting efficiency very quickly. Alloying elements like tungsten, chromium and vanadium, are used to produce high speed steel tool material. Its red hardness property is more than that of high carbon steel.

High speed steel is used for making solid tools, brazed tools and inserted bits. It is costlier than high carbon steel. Carbide cutting tools can retain their hardness at very high temperatures, and their cutting efficiency is higher than that of high speed steel. Due to its brittleness and cost, a carbide tool cannot be used as a solid tool. It is used as a brazed tool and throw away tool bit.

Lathe cutting tool types

The tools used on lathes are

- Solid type tools
- Brazed type tools
- Inserted bits with holders
- Throw-away type tools. (carbide)

Solid tools (Fig 1)

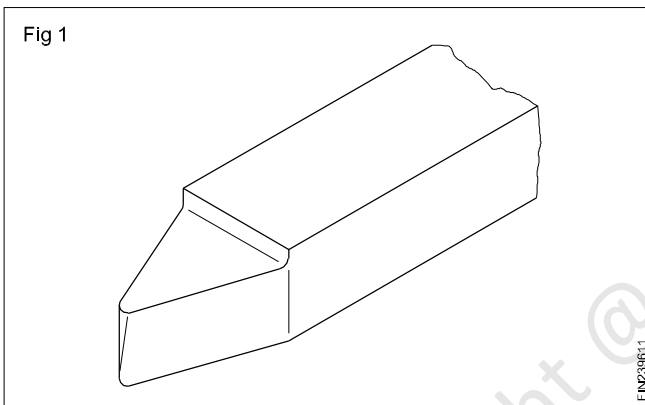

These are tools having their cutting edges ground on solid bits of square, rectangular and round cross-sections. Most of the lathe cutting tools are of the solid type, and high carbon steel and high speed steel tools are used. The length and cross-section of the tool depend upon the capacity of the machine, the type of tool post and the nature of the operation.

Inserted bits with holders (Fig 2)

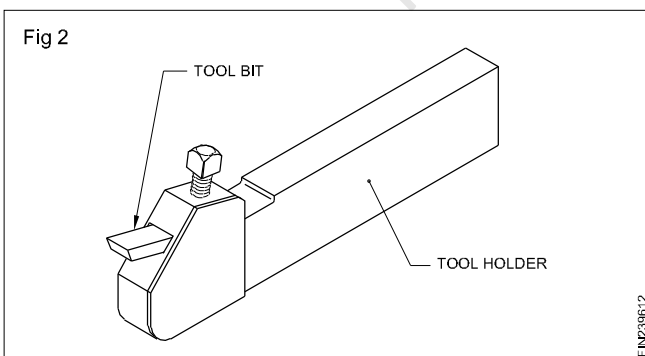

Solid high speed steel tools are costly; hence, they are sometimes used as inserted bits. These bits are small in sizes, and are inserted in the holes of the holder. These holders are held and clamped in the tool posts to carry out the operations. The disadvantage in this type of tools is that the rigidity of the tool is poor.

Brazed tools (Fig 3)

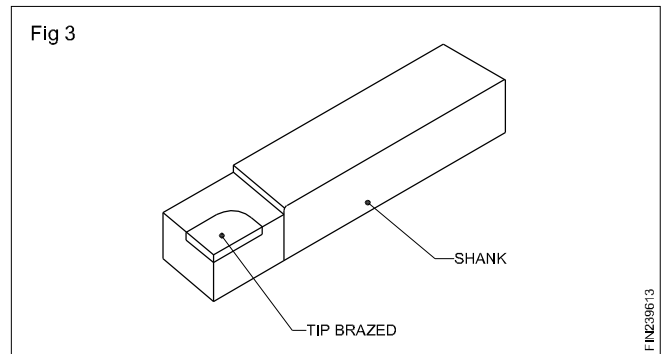

These tools are made up of two different metals. The cutting portions of these tools are of cutting tool materials, and the body of the tools do not possess any cutting ability, and are tough. Tungsten carbide tools are mostly of the brazed type. Tungsten carbide bits of square, rectangular and triangular shape are brazed to the tips of the shank. The tips of the shank metal pieces are machined on the top surface according to the shape of the fits so as to accommodate the carbide bits. These tools are economical, and give better rigidity for the tools than the inserted bits clamped in the tool-holders. This is applicable to high speed steel brazed tools also.

Throw-away type tools (Fig 4)

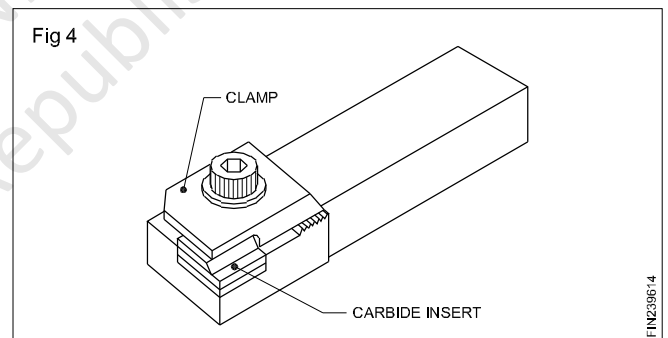

Carbide brazed tools when blunt or broken need grinding which is time consuming and expensive. Hence, they are used as throw-away inserts in mass production. Special tool-holders are needed and the carbide bits of rectangular, square or triangular shapes are clamped in the seating faces and machined on this type of special holders.

The seating faces are machined in such a way that the rake and clearances needed for the cutting bits are automatically achieved when the bits are clamped.

Lathe cutting tool shapes

Lathe cutting tools are available in a variety of shapes for performing different operations. Some of the lathe cutting tools generally used are:

- Facing tool (Figs 5a and 5b)

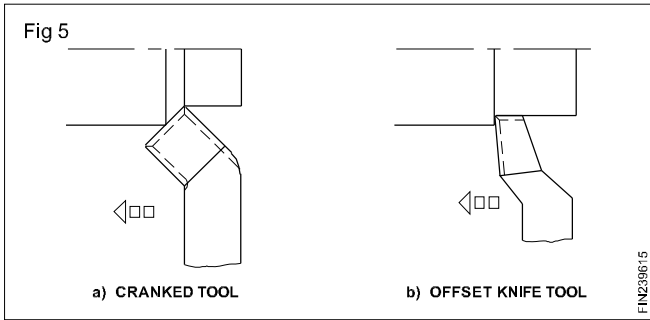

- Knife edge tool (Fig 6)

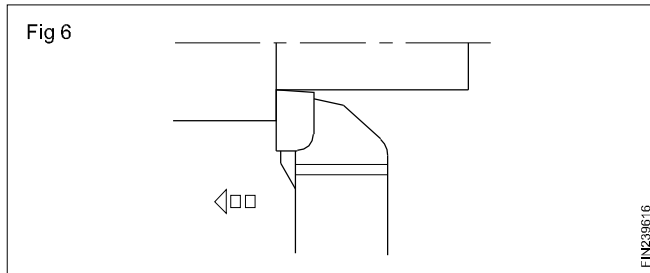

- Roughing tool (Fig 7)

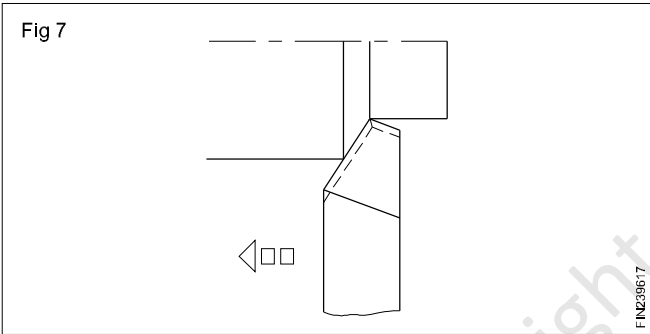

- Round nose finishing tool (Fig 8)

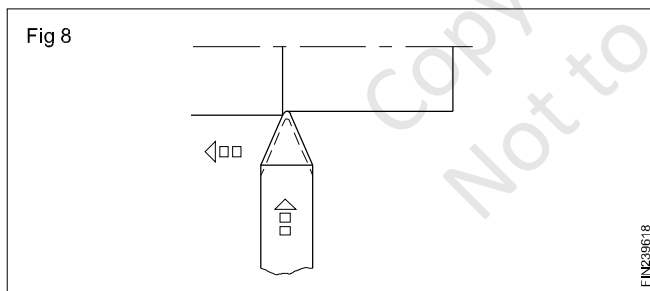

- Broad nose finishing tool (Fig 9)

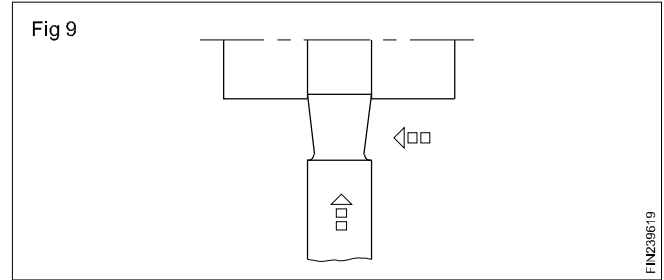

- Undercutting tool/parting off tool (Fig 10)

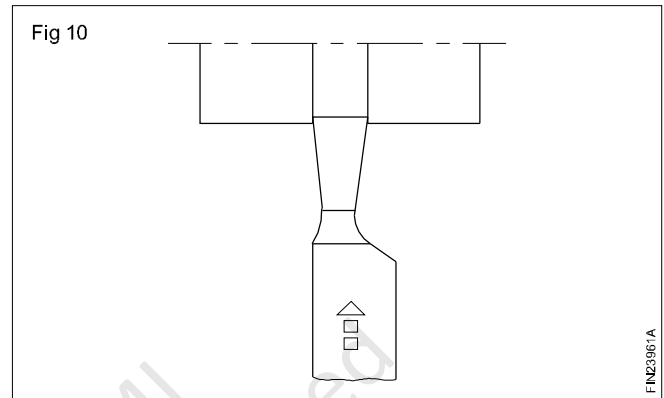

- External threading tool (Fig 11)

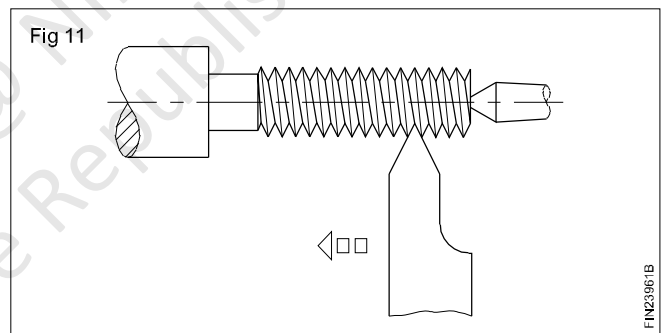

- Boring tool (Fig 12)

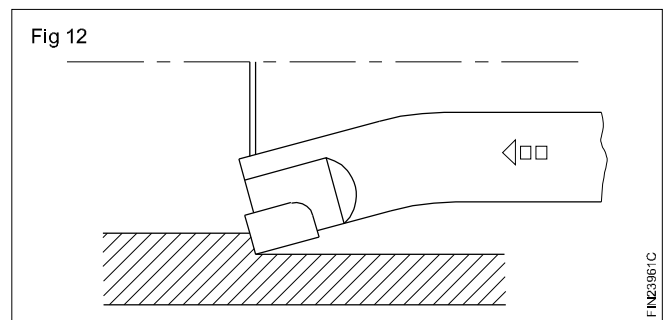

Necessity of grinding angles

Objectives: At the end of this lesson you shall be able to

- name the different angle of the tool
- state use of the each angle
- state the effect of the incorrect angle.

Approach angle (Fig 1)

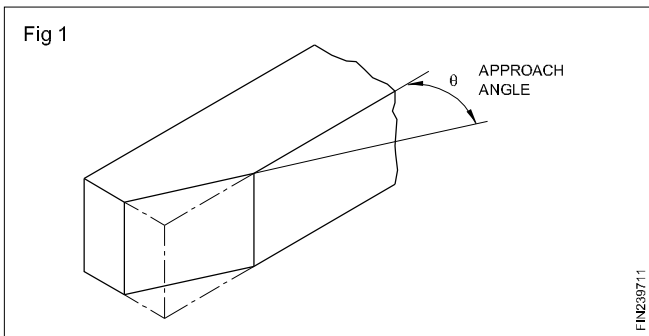

This is also known as side cutting-edge angle. This is ground on the side of the cutting tool. The cutting will be oblique while cutting. The angle ground may range from 25° to 40° but as a standard a 30° angle is normally provided. The oblique cutting has the advantages over the orthogonal cutting, in which the cutting edge is straight. More depth of cut is given in the case of oblique cutting, since, when the tool is fed to the work, the contact surface of the tool increases gradually as the tool advances, whereas in the case of the orthogonal cutting, the length of the cutting edge for the given depth fully contacts the work from the beginning itself which gives a sudden maximum load on the tool face. The area over which heat is distributed is greater in oblique cutting. (Fig 2)

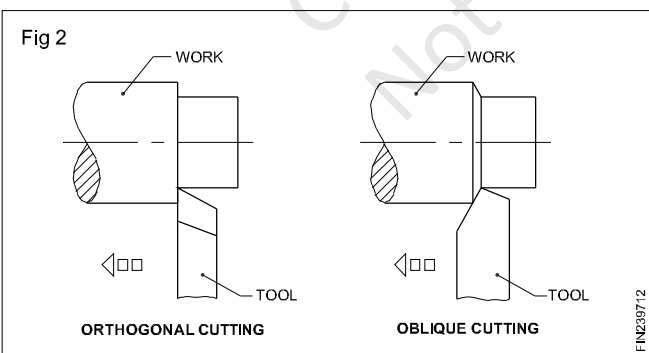

Trail angle (Fig 3)

It is also known as end-cutting edge angle, and is ground at 30° to a line perpendicular to the axis of the tool, as illustrated.

The approach angle and trail angle ground will form the wedge angle of 90° for the tool.

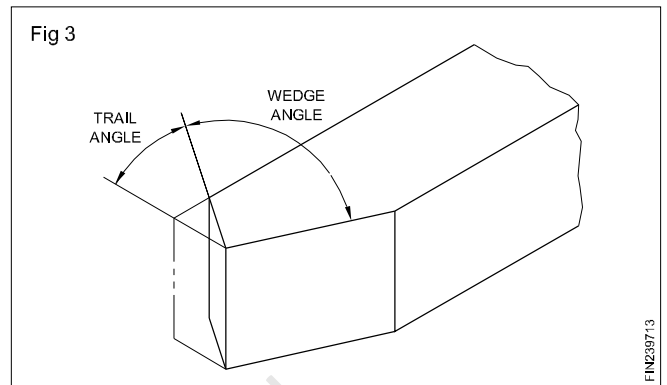

Top or back rake angle (Fig 4)

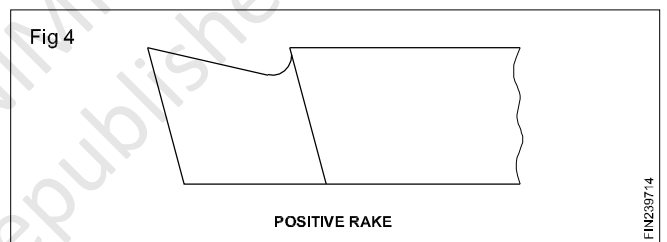

The rake angle ground on a tool controls the geometry of chip formation. Thereby, it controls the cutting action of the tool. The top or back rake angle of the tool is ground on the top of the tool, and it is a slope formed between the front of the cutting edge and the top of the face. If the slope is from the the front towards the back of the tool, it is known as a positive top rake angle, and if the slope is from the back of the tool towards the front of the cutting edge, it is known as a negative back rake angle. (Fig 5)

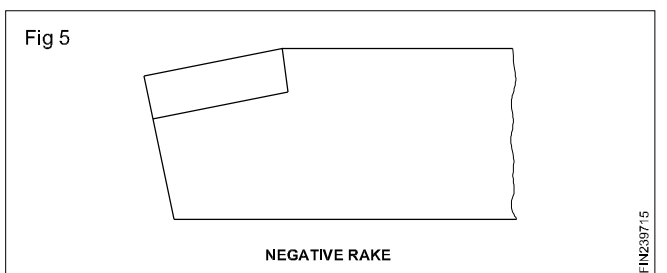

The top rake angle may be ground positive, negative or zero according to the material to be machined. When turning soft, ductile materials, which form curly chips, the positive top rake angle ground will be comparatively more than for turning hard brittle metals.

When turning hard metals with carbide tools, it is the usual practice to give a negative top rake. Negative top rake tools have more strength than tools with positive top rake angles.

Side rake angle (Fig 6)

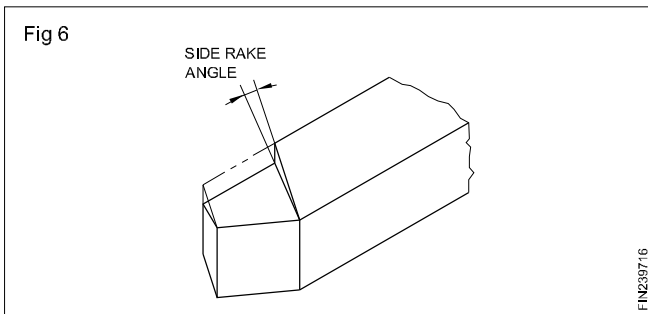

A side rake angle is the slope between the side of the cutting edge to the top face of the tool width wise. The slope is from the cutting edge to the rear side of the tool. It varies from 0° to 20° , according to the material to be machined.

The top and side rake, ground on a tool control the chip flow, and this results in a true rake angle which is the direction in which the chip that shears away from the work passes.

Front clearance angle (Fig 7)

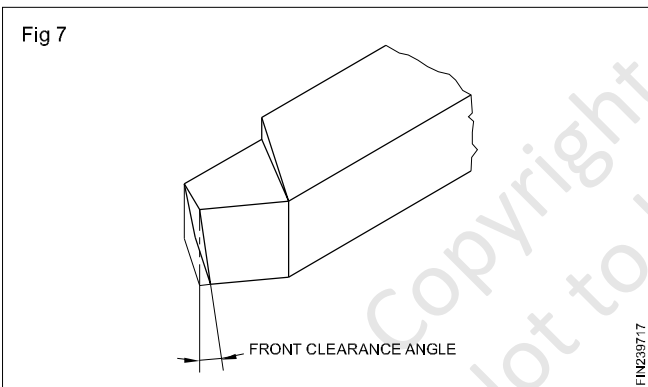

It is the slope between the front of the cutting edge to a line perpendicular to the axis of the tool drawn downwards which is known as the front clearance angle. The slope is from the top to the bottom of the tool, and permits only the cutting edge to contact the work, and avoids any rubbing action. If the clearance ground is more, it will weaken the cutting edge.

Side clearance angle (Fig 8)

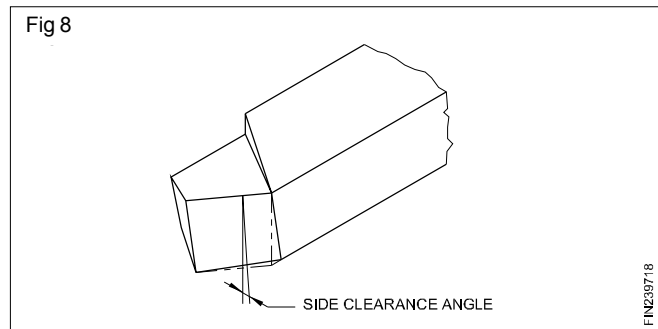

The clearance angle is the slope formed between the side cutting edge of the tool with a line perpendicular to the tool axis drawn downwards at the side cutting edge of the tool. The slope is from the top of the side cutting edge to the bottom face. This is also ground to prevent the tool from rubbing with the work, and allows only the cutting edge to contact the work during turning. The side clearance angle needs to be increased when the feed rate is increased.

When grinding rake and clearance angles, it is better to refer to the standard chart provided with the recommended values and grind. However, actual operation will indicate the performance of the tool, and will indicate to us, if any modifications are needed for the angles ground on the tool.

Lathe cutting speed and feed, use of coolants, lubricants

Objectives: At the end of this lesson you shall be able to

- distinguish between cutting speed and feed
- read and select the recommended cutting speed for different materials from the chart
- point out the factors governing the cutting speed
- state the factors governing feed.

Cutting speed is the speed at which the cutting edge passes over the material, and it is expressed in metres per minute. (Fig 1)

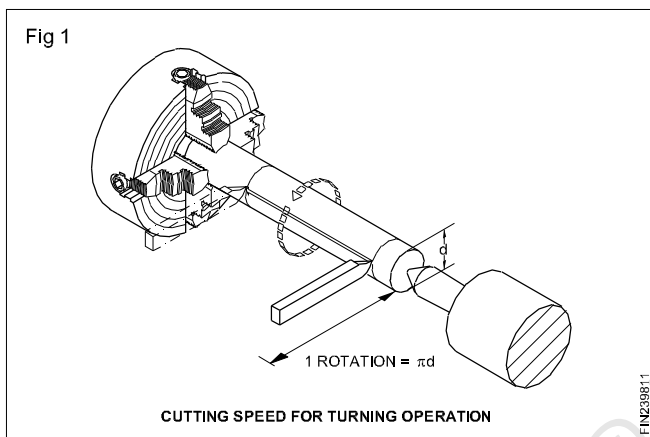

When a work of a diameter 'd' is turned in one revolution the length of the portion of work in contact with the tool is $\pi \times d$. When the work is making 'n' rev/min, the length of the work in contact with the tool is $\pi \times D \times n$. This is converted into metres and expressed in a formula form as

$$V = \frac{\pi dn}{1000} \text{ metre/min}$$

where

V = cutting speed in m/min.

$$\pi = 3.14$$

d = diameter of the work in mm.

n = RPM.

When more material is to be removed in lesser time, a higher cutting speed is needed. This makes the spindle to run faster but the life of the tool will be reduced due to more heat being developed. The recommended cutting speeds are given in a chart. As far as possible the recommended cutting speeds are to be chosen from the chart and the spindle speed calculated before performing the operation. (Fig 2) Correct cutting speed will provide normal tool life under normal working condition.

Example

Find out the rpm of a spindle for a 50 mm bar to cut at 25 m/min.

$$V = \frac{\pi dn}{1000} \quad n = \frac{1000V}{\pi \times D}$$

$$\frac{1000 \times 25}{3.14 \times 50} = \frac{500}{3.14} = 159 \text{rpm}$$

Factors governing the cutting speed

- Finish required
- Depth of cut
- Tool geometry
- Properties and rigidity of the cutting tool and its mounting.
- Properties of the workpiece material
- Rigidity of the workpiece
- The type of cutting fluid used.

Feed (Fig 3)



The feed of the tool is the distance it moves along the work for each revolution of the work and it is expressed in mm/rev.

The factors governing the feed are:

- Tool geometry
- Surface finish required on work
- Rigidity of the tool.

Rate of metal removal

The volume of metal removal is the volume of chip that is removed from the work in one minute, and it is found by multiplying the cutting speed, feed rate and the depth of cut.

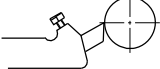
Cutting speed 30 m / min	Length of metal passing over cutting tool in one revolution	Calculated RPM of spindle
Fig 2  $\text{Ø } 25 \text{ mm}$	-----78.56 mm	1528
 $\text{Ø } 50 \text{ mm}$	-----157.12 mm	764
 $\text{Ø } 75 \text{ mm}$	-----235.68 mm	509.3

Relationship of RPM to the cutting speed on different diameters.

TABLE 1

Cutting speeds and feeds for H.S.S tool

Material being turned	Feed mm/rev	Cutting speed m/min
Aluminium	0.2-1.00	70-100
Brass (alpha)-ductile	0.2-1.00	50-80
Brass (free cutting)	0.2-1.5	70-100
Bronze (phosphor)	0.2-1.00	35-70
Cast iron (grey)	0.15-0.7	25-40
Copper	0.2-1.00	35-70
Steel (mild)	0.2-1.00	35-50
Steel (medium-carbon)	0.15-0.7	30-35
Steel (Alloy-high tensile)	0.08-0.3	5-10
Thermo-setting plastics	0.2-1.00	35-50

Note

For super HSS tools the feeds should remain the same, but cutting speeds could be increased by 15% to 20%.

A lower speed range is suitable for heavy, roughing cuts. A higher speed range is suitable for light, finishing cuts.

The feed is selected to suit the finish required and the rate of metal removal.

When carbide tools are used, 3 to 4 times higher cutting speed to that required for H.S.S. tools may be chosen.

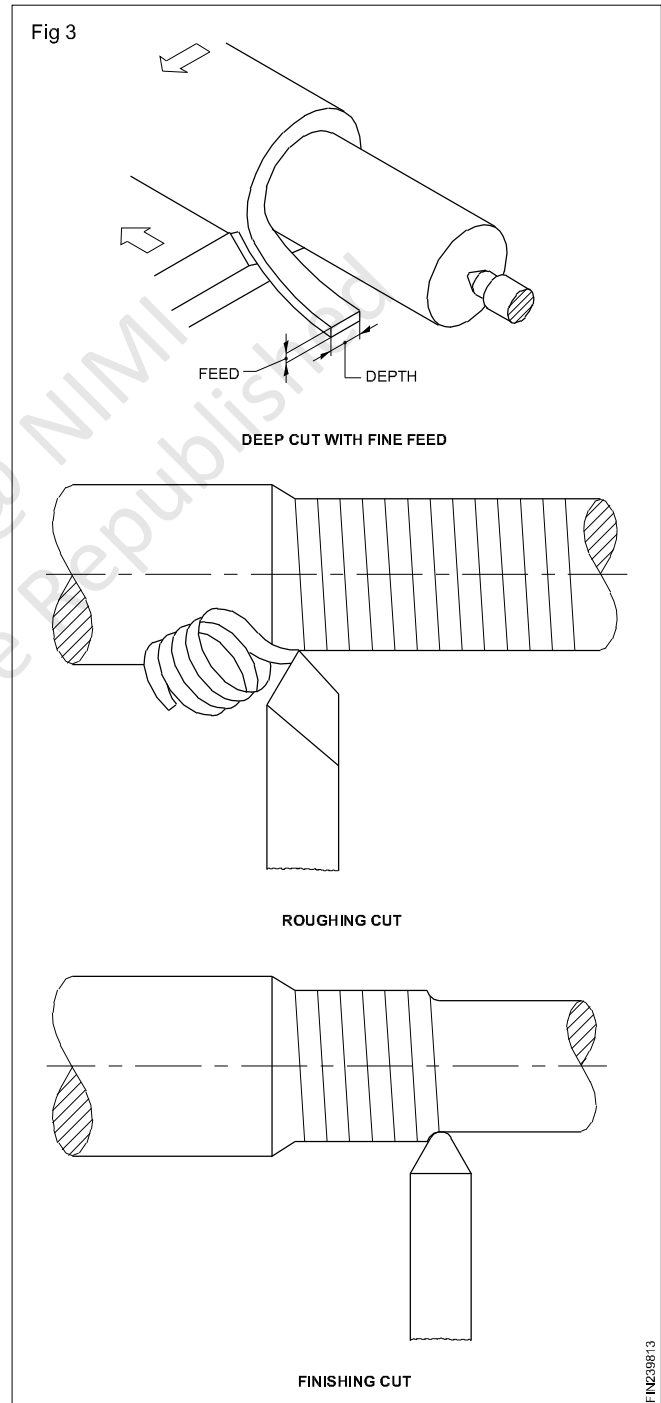

Comparison of HSS and Carbide Tools

HSS Tool	Carbide Tool
<ul style="list-style-type: none"> • Ferrous tool material have iron as their chief constituent. • Alloying tungsten, chromium and vanadium to high carbon steel, high speed steel tool material is produced. • Cutting speed is low. • Solid tool. • Cost low. 	<ul style="list-style-type: none"> • Non-Ferrous tool material do not have iron. • Carbide cutting tools can retain their hardness at very high temperature that of high speed steel. • Cutting speed is high. • It is a brazed tool bit and throw away tool bit die to brittleness. • Cost high.

Coolants & lubricants (Cutting fluids)

Objectives: At the end of this lesson you shall be able to

- state the properties of cutting fluids
- state the purpose of using a cutting fluid
- name the different cutting fluids
- distinguish the characteristics of each type of cutting fluids
- select a proper cutting fluid to suit various materials and machining operations.

Coolants (Cutting fluids)

Coolants (Cutting fluids) play an important role in reducing the wear of cutting tools.

Coolants (Cutting fluids) are essential in most metal cutting operations. During a machining process, considerable heat and friction are created by the plastic deformation of metal occurring in the shear zone when the chip slides along the chip tool interface. This heat and friction cause the metal to adhere to the cutting edge of the tool, and the tool may break down. The result is poor finish and inaccurate work.

The advantages of a cutting fluid is it :

- Cools the tool and the workpiece
- Lubricates the chip / tool interface and reduces the tool wear due to friction
- Prevents chip welding
- Improves the surface finish of the workpiece
- Flushes away the chips
- Prevents corrosion of the work and the machine.

A good cutting fluid should have the following properties.

- Good lubricating quality
- Rust resistance
- Stability both in storage and in use

- Resistant to separation from solution after it is mixed with water
- Transparency
- Relatively low viscosity
- Non-flammability

The following are the main purposes of cutting fluids.

- To cool the cutting tool and the workpiece as heat is generated during cutting operation because of friction between the tool and the workpiece.
- To cool the cutting edge of the tool and to prevent any wear on the tool.
- To prevent the formation of chip welding.
- To give a good cutting efficiency to the tool.
- To give a good surface finish on the job.
- To act as a lubricant for the tool and the machine.

The different types of cutting fluids are:

- Soluble mineral oils
- Straight mineral oils
- Straight fatty oils
- Compounded or blended oils
- Sulphurised oils.

Cutting fluids - Types and Characteristics

Soluble mineral oils

They are made from mineral oils with emulsifying material added to make for mixing with water. Soluble oil is diluted with water to form an emulsion. The water cools whilst the oil lubricates. The extent of dilution depends upon the type of operation.

Straight mineral oils

They are purely mineral oils. Lighter oils are used when cooling and lubrication are required. Heavier oils are used when lubrication is mainly essential. They are used on automats. They protect the machine parts and workpieces from rusting.

Lard oils

Lard oils are usually blended with mineral oils to prevent deterioration, reduce cost and destroy the objectionable odour. For machining under extreme conditions, they are an excellent lubricant.

Sulphurised oils

To suit extreme cutting conditions of modern tools sulphurised oils have been devised. The addition of sulphur improves performance on difficult operations. Its lubricating property prevents the welding of chip on to the tool.

Coolants (Cutting fluids) play an important role in reducing the wear of cutting tools.

Recommended cutting fluids for various metals

Material	Drilling	Reaming	Threading	Turning	Milling
Aluminium	Soluble oil Kerosene Kerosene and Lard oil	Soluble oil Kerosene Mineral oil	Soluble oil Kerosene and Lard oil	Soluble oil	Dry Soluble oil Lard oil Mineral oil
Brass	Dry Soluble oil Mineral oil Lard oil	Dry Soluble oil	Soluble oil Lard oil	Soluble oil	Dry Soluble oil
Bronze	Dry Soluble oil Mineral oil Lard oil	Dry Soluble oil Mineral oil Lard oil	Soluble oil Lard oil	Soluble oil	Dry Soluble oil Mineral oil Lard oil
Cast iron	Dry Air jet Soluble oil Lard oil	Dry Soluble oil Mineral oil Lard oil	Dry Sulphurized oil Mineral oil Lard oil	Dry Soluble oil	Dry Soluble oil
Copper	Dry Soluble oil Mineral oil Lard oil Kerosene Oil	Soluble oil Lard oil	Soluble oil Lard oil	Soluble oil	Dry Soluble oil
Steel Alloys	Soluble oil Sulphurized oil Mineral oil Lard oil	Soluble oil Sulphurized oil Mineral oil Lard oil	Sulphurized oil Lard oil	Soluble oil	Soluble oil Mineral Lard oil
General purpose	Soluble oil Sulphurized oil Lard oil	Soluble oil Sulphurized oil Lard oil	Sulphurized oil Lard oil	Soluble oil	Soluble oil Lard oil steel

Lubricants

Objectives: At the end of this lesson you shall be able to

- state the purpose of using lubricants
 - state the properties of lubricants
 - state the qualities of a good lubricant.
-

With the movement of two mating parts of the machine, heat is generated. If it is not controlled, the temperature may rise resulting in total damage of the mating parts. Therefore a film of cooling medium with high viscosity is applied between the mating parts which is known as a 'lubricant'.

A 'lubricant' is a substance having an oily property available in the form of fluid, semi-fluid, or solid state. It is the lifeblood of the machine, keeping the vital parts in perfect condition and prolonging the life of the machine. It saves the machine and its parts from corrosion, wear and tear and it minimises friction.

Purpose of using lubricants

- Reduces friction
- Prevents wear
- Prevents adhesion
- Aids in distributing the load
- Cools the moving elements
- Prevents corrosion
- Improves machine efficiency

Properties of Lubricants

Viscosity

It is the fluidity of an oil by which it can withstand high pressure or load without squeezing out from the bearing surface.

Oiliness

Oiliness refers to a combination of wettability, surface tension and slipperiness. (The capacity of the oil to leave an oily skin on the metal).

Flas point

It is the temperature at which the vapour is given off from the oil (it decomposes under pressure soon).

Fire point

It is the temperature at which the oil catches fire and continues to be in flame.

Pour point

The temperature at which the lubricant is able to flow when poured.

Emulsification and de-emulsibility

Emulsification indicates the tendency of an oil to mix immediately with water to form a more or less stable emulsion. De-emulsibility indicates the readiness with which subsequent separation will occur.

Chucks and chucking - the independent 4 jaw chuck

Objectives: At the end of this lesson you shall be able to

- state the constructional features of a 4 jaw chuck
- name the parts of a 4 jaw chuck.

4 Jaw chuck (Fig 1)

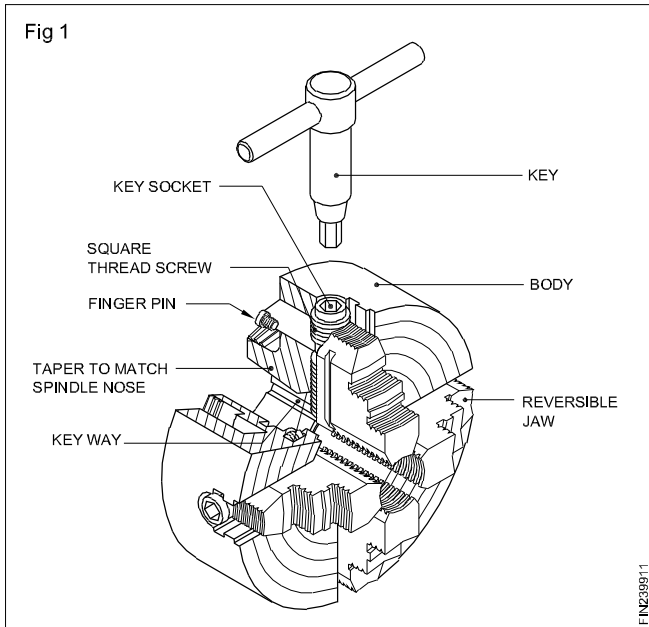

The four jaw chuck is also called as independent chuck, since each jaw can be adjusted independently; work can be trued to within 0.001" or 0.02mm accuracy, using this chuck.

This type of chuck is much more heavily constructed than the self-centering chuck, and has much greater holding power. Each jaw is moved independently by a square thread screw. The jaws are reversible for holding large diameter jobs. The independent 4 jaw chuck has four jaws, each working independently of the others in its own slot in the chuck body and actuated by its own separate square threaded screw. By suitable adjustment of the jaws, a workpiece can be set to run either true or eccentric as required.

To set the job for the second time, it can be trued with the help of a dial test indicator.

The check on the workpiece should be carried out near the chuck and repeated as far from it as the workpiece permits, to ensure that the work is not held in the chuck at an angle to the axis of rotation.

The independent adjustment also provides the facility of deliberately setting the work off-centre to produce an eccentric workpiece. (Fig 2)

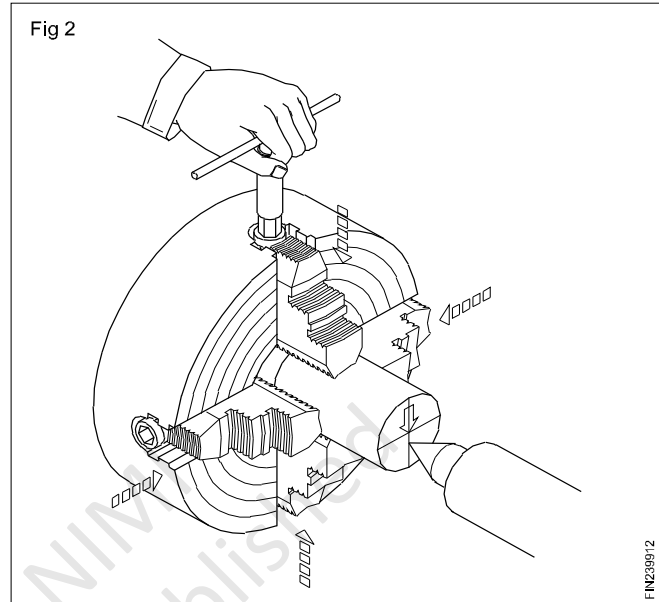

The parts of a 4 jaw chuck are:

- Back plate
- Body
- Jaws
- Square threaded screw shaft.

Back plate

The back plate is fastened to the back of the body by means of Allen screws. It is made out of cast iron/steel. Its bore is tapered to suit the taper of the spindle nose. It has a key way which fits into the key provided on the spindle nose. There is a step in front and on which the thread is cut. A threaded collar, which is mounted on the spindle, locks the chuck by means of the thread, and locates by means of the taper and key. Some chucks do not have back plates.

Body (Fig 1)

The body is made out of cast iron/cast steel and the face is flame-hardened. It has four openings at 90° apart to assemble the jaws and operate them. Four screw shafts are fixed on the periphery of the body by means of finger pins. The screw is rotated by means of a chuck key. The body, hollow in the cross-section, has equi-spaced circular rings provided on the face, which are marked by numerical numbers. Number 1 starts in the middle, and increases towards the periphery.

Jaws (Fig 1)

Jaws are made out of high carbon steel, hardened and tempered, which slide on the openings of the body. These jaws are reversible for holding hollow work.

The back side of the jaws are square-threaded which help in fixing the jaws with the operating screws.

Screw shaft (Fig 1)

The screw shaft is made out of high carbon steel, hardened, tempered and ground. The top portion of the screw shaft is provided with a square slot to accommodate the chuck key. On the body portion, a left hand square thread is cut. In the middle of the screw shaft, a narrow step is made and held by means of finger pins. The finger pins permit the screws to rotate but not to advance.

3 jaw chuck

Objectives: At the end of this lesson you shall be able to

- identify the parts of a 3 jaw chuck
- state the constructional features of a 3 jaw chuck
- distinguish between a 3 jaw chuck and a 4 jaw chuck
- state the merits and demerits of a 4 jaw chuck over a 3 jaw chuck
- specify a chuck.

3 Jaw chuck (Fig 1)

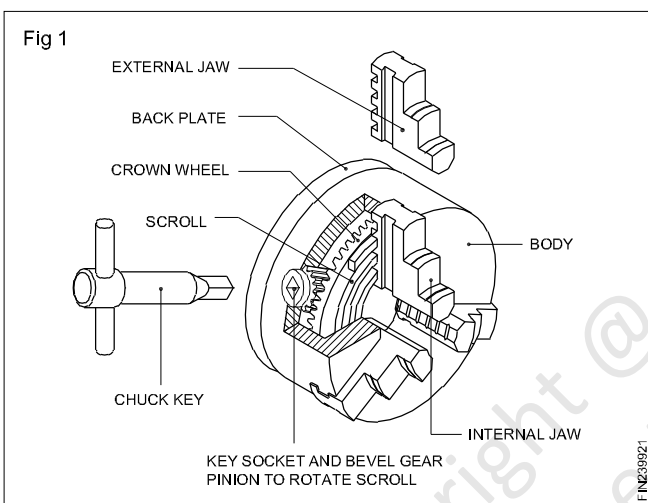

The 3 jaw chuck is also known as a self-centering chuck. The majority of the chucks have two sets of jaws for holding internal and external diameters. Only perfect round work with equally spaced flats divisible by three should be held in a 3 jaw chuck.

From the construction of a 3 jaw chuck it is seen that the scroll not only clamps a component in place, it also locates the component. This is fundamentally a bad practice, since any wear in the scroll and/or the jaws impairs the accuracy of location. Further there is no means of adjustment possible to compensate for this wear.

The jaws of this type of chuck are not reversible, and separate internal and external jaws have to be used.

The parts of a 3 jaw chuck are:

- Back plate
- Body
- Jaws
- Crown wheel and
- Pinion.

Back plate (Fig 1)

The back plate is fastened at the back of the body by means of allen screws. It is made out of cast iron. Its bore is tapered to suit the taper of the spindle nose. It has a key-way which fits into the key provided on the spindle nose. There is a step in the front on which the thread is cut. The threaded collar, which is mounted on the spindle, locks the chuck by means of the thread and locates by mean of the taper and the key.

Body (Fig 1)

The body is made out of cast steel, and the face is hardened. It has three openings 120° apart to assemble the jaws and operate them. Three pinions are fixed on the periphery of the body to operate the jaws by means of a chuck key. It is hollow in its cross-section. A crown wheel is housed inside the body.

Jaws (Fig 1)

The jaws are made out of high carbon steel, hardened and tempered, which slide on the openings of the body. Generally there are two sets of jaws viz. external jaws and internal jaws. External jaws are used for holding solid works. Internal jaws are used for holding hollow works. Steps on the jaws increase the clamping range. The back side of the jaws is cut with scroll thread. Each jaw is numbered in a sequential manner, which helps in fixing the jaws in the corresponding numbered slots.

Crown wheel (Fig 1)

The crown wheel is made out of alloy steel, hardened and tempered. On one side of the crown wheel, a scroll thread is cut to operate the jaws, and the other side is tapered on which bevel gear teeth are cut to mesh with the pinion. When the pinion is rotated by means of a chuck key, the crown wheel rotates, thus causing the jaws to move inward or outward, depending upon the rotation.

Pinion (Fig 1)

Pinion is made out of high carbon steel, hardened and tempered. It is fitted on the periphery of the body. On the

top of the pinion a square slot is provided to accommodate the chuck key. It has a tapered portion on which bevel gear teeth are cut, which match with the crown wheel.

Comparison between 3 jaw chuck and 4 jaw chuck

3 Jaw chuck	4 Jaw chuck
Only cylindrical, hexagonal work can be held.	A wide range of regular and irregular shapes can be held.
Internal and external jaws are available.	Jaws are reversible for external and internal holding.
Setting up of work is easy.	Setting up of work is difficult.
Less gripping power.	More gripping power.
Depth of cut is comparatively less.	More depth of cut can be given.
Heavier jobs cannot be turned.	Heavier jobs can be turned.
Workpieces cannot be set for eccentric turning.	Workpieces can be set for eccentric turning.
Concentric circles are not provided on the face.	Concentric circles are provided which help for approximate setting of jaws.
Accuracy decreases as the chuck gets worn out.	There is no loss of accuracy as the chuck gets worn out.

Merits of a 4 jaw chuck

A wide range of regular and irregular shapes can be held.

Work can be set to run concentrically or eccentrically at will.

Has considerable gripping power, and hence heavy cuts can be given.

The jaws are reversible for internal and external work.

Work can be readily performed on the end face of the job.

There is no loss of accuracy as the chuck gets worn out.

De-merits of a 4 jaw chuck

Workpieces must be individually set.

The gripping power is so great that fine work can be easily damaged during setting.

Merits of a 3 jaw chuck

Work can be set with ease.

A wide range of cylindrical and hexagonal work can be held.

Internal and external jaws are available.

De-merits of a 3 jaw chuck

Accuracy decreases as chuck becomes worn out.

Run out cannot be corrected.

Only round and hexagonal components can be held.

When accurate setting or concentricity with an existing diameter is required, a self-centering chuck is not used.

Specification of chuck

To specify a chuck, it is essential to provide :

Type of chuck.

Capacity of chuck.

Diameter of the body.

Width of the body.

The method of mounting to the spindle nose.

Example

3 Jaw self-centering chuck.

Gripping capacity 450 mm.

Diameter of the body 500 mm.

Width of the body 125 mm.

Tapered or threaded method of mounting.

Method of cleaning the thread of the chuck mounting

Objective: At the end of this lesson you shall be able to

- state the uses of thread cleaner.

Thread cleaners are used to clean all the mating parts of the chuck and spindle as, otherwise, the dirt on these surfaces could result in the following.

Cause the chuck to run out of true.

Damage the threads or taper on the spindle or chuck.
(Fig 1)

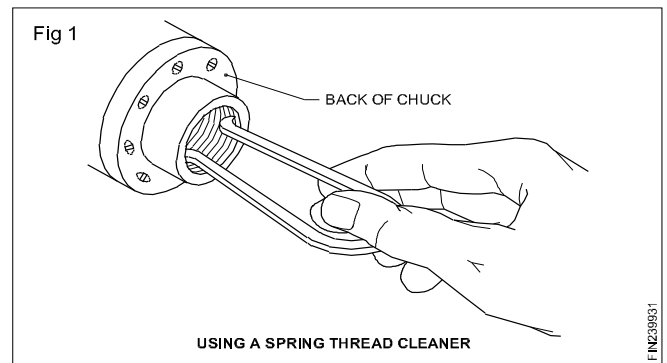

Mounting and dismounting of chucks

Objective: At the end of this lesson you shall be able to

- explain the method of mounting and dismounting chucks from spindle noses.

To perform lathe operations on work materials, it may not be always possible to have only one type work-holding device fitted to the spindle. Hence it becomes an absolute necessity for dismounting the work-holding device already assembled to the spindle and mount that work-holding device which is needed for the work in hand.

For an easy understanding of different spindle noses and their applications, the mounting of different work-holding devices are illustrated.

When mounting a chuck on the headstock spindle, exercise care to prevent damage occurring to the chuck or spindle.

Damage may reduce the accuracy of the lathe. The points set out below are important and should be followed.

Before mounting

Before attempting to mount a chuck, ensure that it is the correct one for the lathe and for the job in hand.

Do not use power to mount a chuck on spindle noses.

To prevent such damage from occurring, take the following steps.

Place a wooden board on the lathe bed when mounting light chucks to prevent damage to the slideways. (Fig 1)

For large chucks place a wooden cradle between the chucks and the lathe bed. (Fig 2)

In addition to protecting the bed slideways it makes fitting the chuck easier and safer.

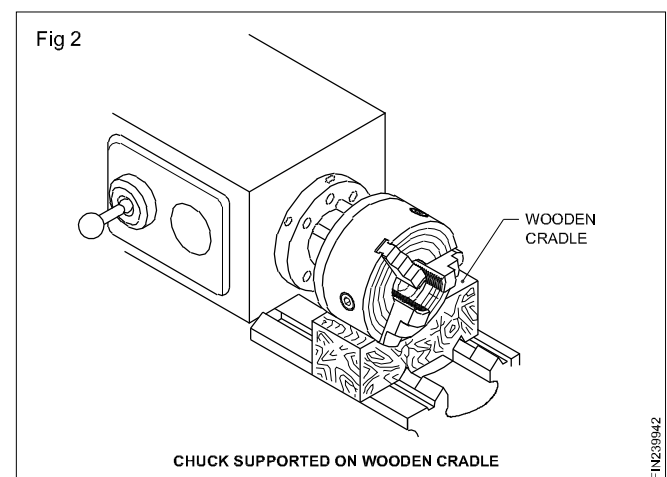
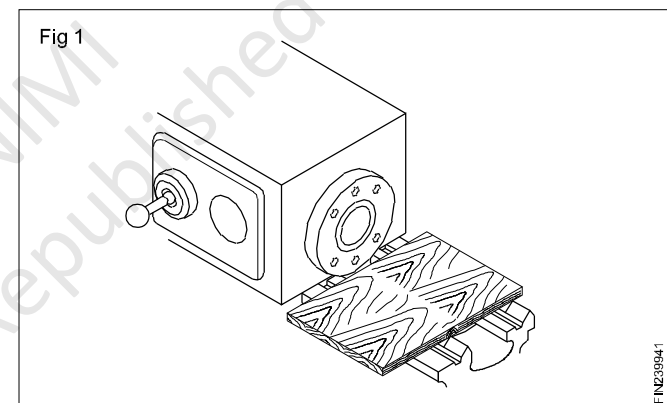

Always seek assistance when mounting large and heavy chucks.

Lubricate the mating surfaces with a light film of oil.

After mounting

Set the speed-change lever to the slowest speed.

Turn on the power to the motor.

Switch on the motor.

Engage the clutch lever.

The chuck would now begin revolving.

Check that the diameter and face of the chuck are running true by observing the surfaces.

Mounting chuck on to the threaded spindle (Fig 3)

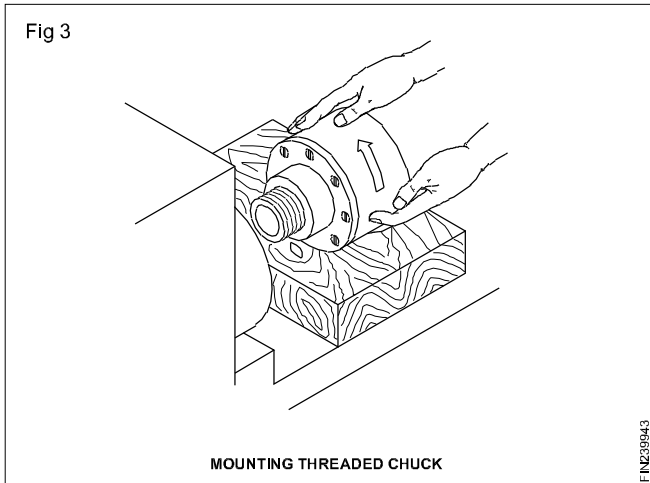

Switch off the motor.

Place the chuck on the wooden plank or cradle and slide it close to the spindle nose.

Turn the spindle anticlockwise by hand and engage the chuck on the spindle threads. (Fig 3)

Set the speed-change lever to the slowest speed. Screw the chuck in until it fits firmly on the spindle.

The chuck should easily screw into the spindle. If any resistance is felt, remove the chuck and check that the threads are clean and not damaged.

Mounting on tapered spindle (Fig 4)

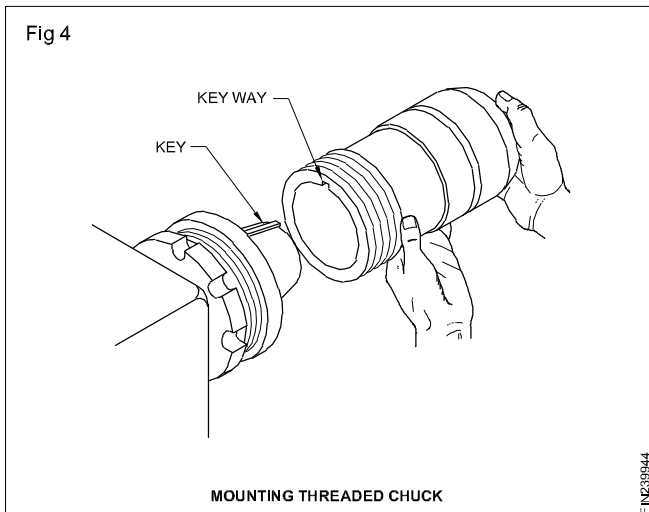

Switch off the motor.

Hence the chuck on the wooden board or cradle and slide it close to the spindle nose.

Turn the spindle by hand until the key on the spindle nose lines up with the keyway in the chuck.

Set the speed-change lever to the slowest speed.

Push the chuck on to the spindle and turn the locking ring anticlockwise. (Fig 4)

The figure given here illustrates a small chuck held with both hands and being mounted. Engage the special 'C' spanner on the locking ring.

The spanner should fit around the top of the locking ring with the handle pointing downwards. Grip the end of the handle with one hand and firmly strike the other end with the other hand in an anticlockwise direction. This would securely tighten the locking ring. (Fig 5)

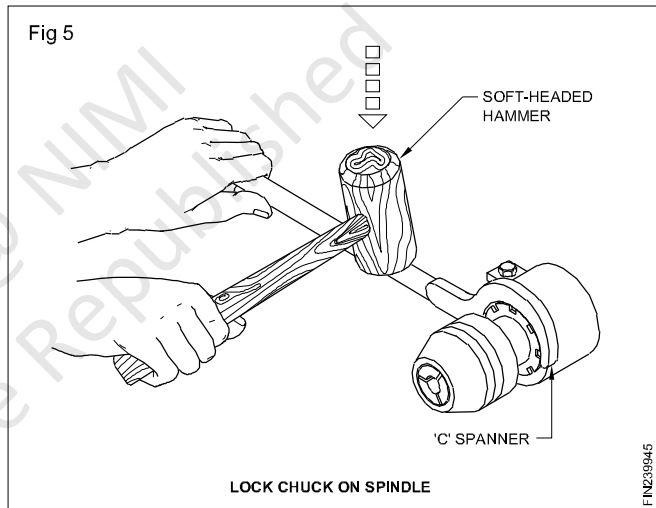

Mounting on a cam-lock spindle (Fig 6)

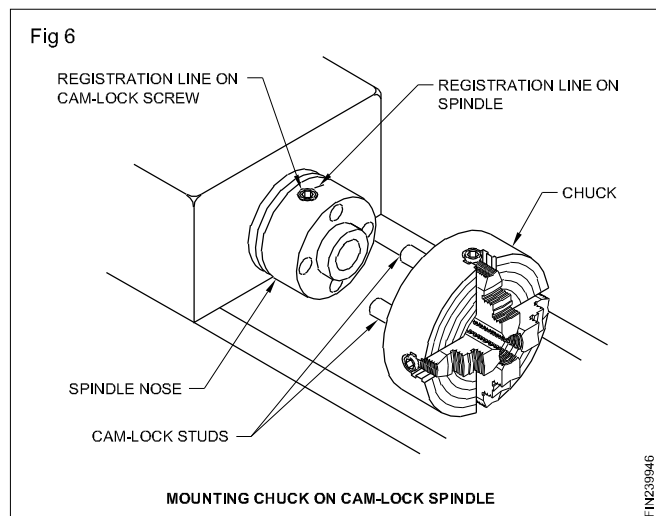

Switch off the motor.

Place the chuck on a wooden board or cradle and slide it close to the spindle nose. Disengage the clutch to permit free rotation of the spindle. Insert the correct chuck key into a cam-locking screw on the spindle.

Turn each cam-locking screw so that the registration line is vertical or aligns with the corresponding line on the spindle. Turn the spindle by hand until the clearance holes on the spindle align with the cam-lock studs on the chuck.

Set the speed. Change lever to the slowest speed. Push the chuck on to the spindle. Tighten each cam-lock screw in a clockwise direction.

Mounting on to a bolted spindle (Figs 7 and 8)

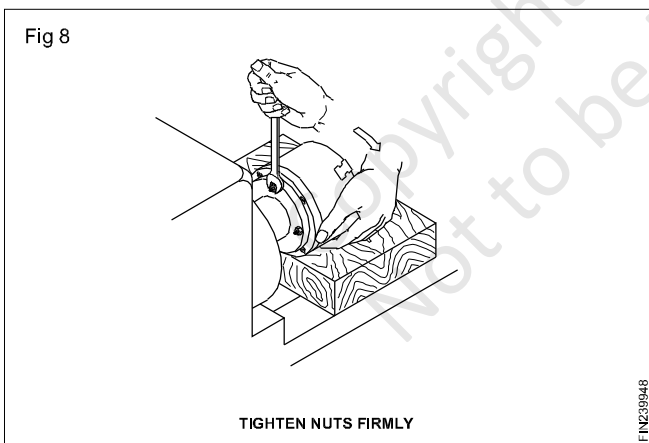
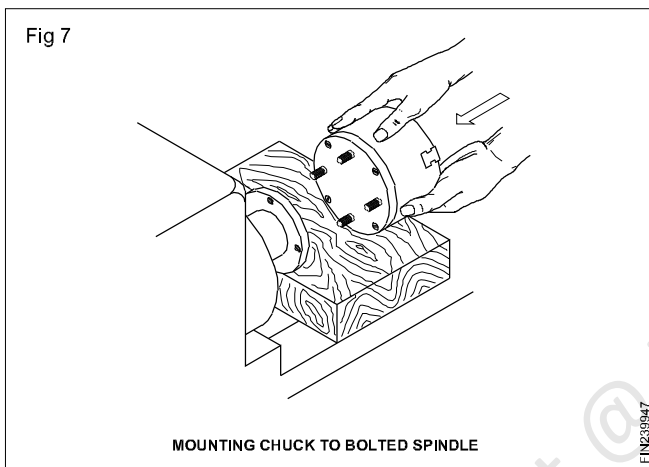

Switch off the motor.

Place the chuck on a wooden board or cradle. Remove nuts and washers from the studs on the chuck. Disengage the clutch to permit free rotation of the spindle. Turn the spindle by hand until the key in the spindle lines up with the slot in the chuck. Set the speed- change lever to the slowest speed. Push the chuck on to the spindle. Fit washers and nuts to the studs.

Hold the chuck in position when fitting nuts.

Tighten the nuts in an anticlockwise direction using a spanner on the opposite nuts.

Dismounting chucks from a threaded spindle (Fig 9)

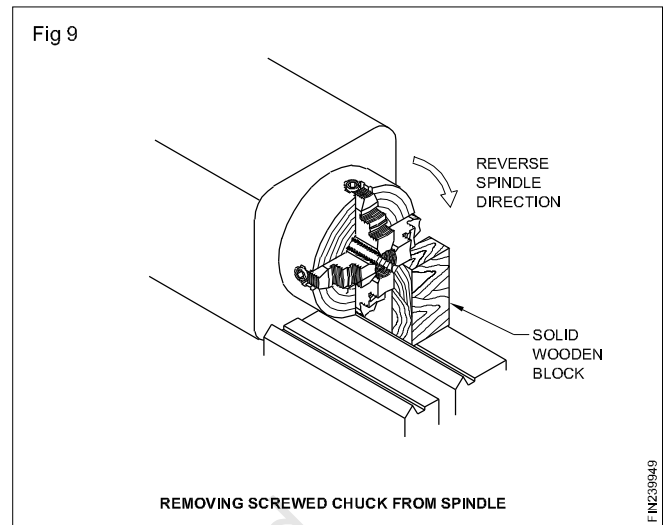

Switch off the motor. Set the speed change lever to the slowest speed. Place a solid wooden block between one of the chuck jaws and the rear of the lathe-bed.

The length of the wooden block should be slightly less than the centre height of the lathe.

Turn the lathe spindle clockwise by hand to loosen the chuck from the spindle nose.

Remove the wooden block. Place the wooden board or cradle on the lathe-bed. Unscrew the chuck from the spindle. Clean and store the chuck (Fig 10)

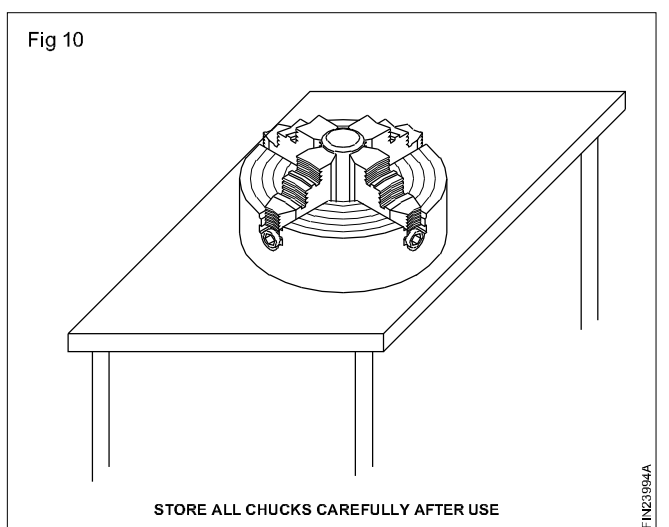

Face plate

Objectives: At the end of this lesson you shall be able to

- state the types of face plate
- state the uses of face plates

The different types of face plates are:

- Face plates with only elongated radial slots (Fig 1)

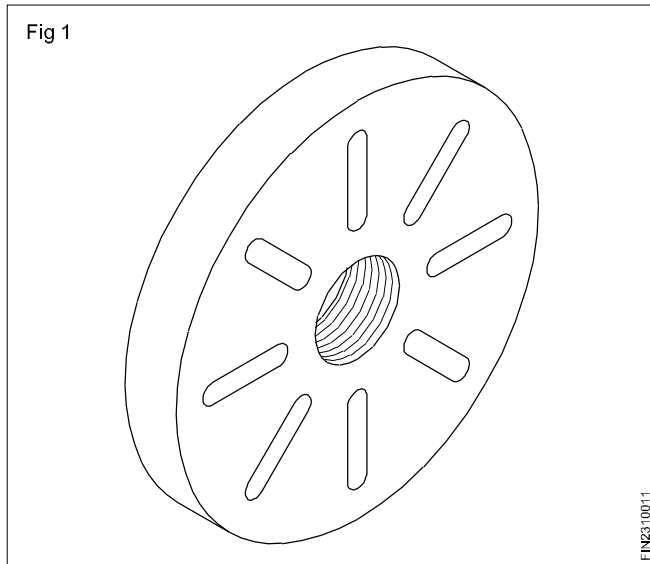

- Face plates with elongated slots 'T' slots. (Fig 2)

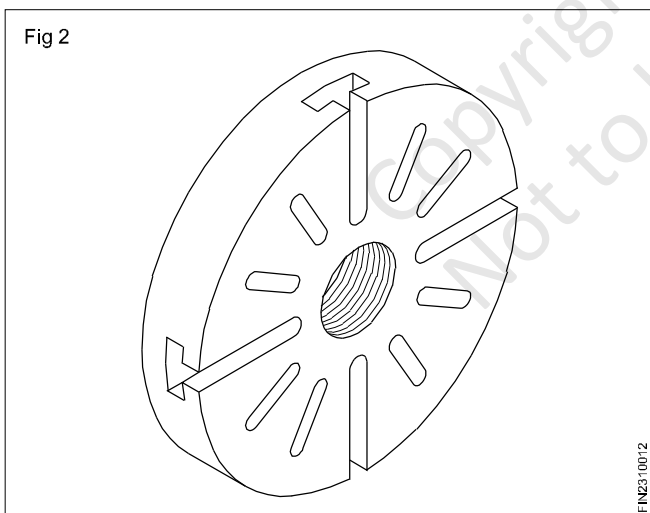

- Face plates with elongated radial slots and additional parallel slots. (Fig 3)

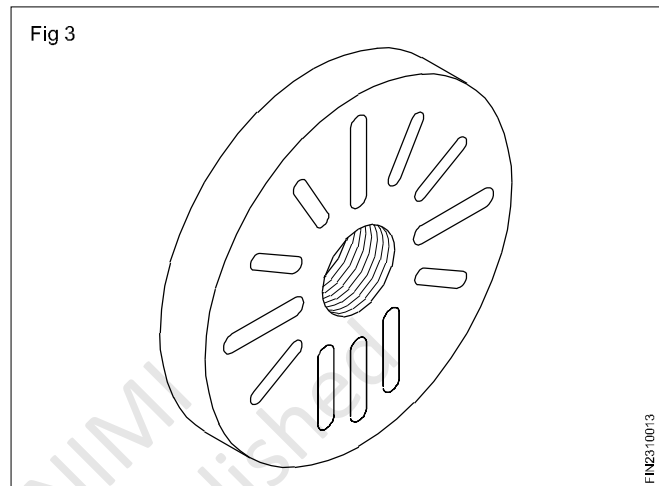

Face plates are used along with the following accessories.

Clamps, 'T' bolts, Angle plate, Parallels, counterweight, Stepped block, 'V' Block etc.

Large, flat, irregular shaped workpieces, castings, jigs and fixtures may be firmly clamped to a face plate for various turning operations.

A work can be mounted on a face plate while the face plate is on the lathe spindle or on the workbench. If the workpiece is heavy or awkward to hold, the workpiece is mounted while the face plate is on the workbench. Before mounting the face plate set up to the spindle, it is advantageous to locate the workpiece on the face plate and centre the workpiece. Centre a punch mark or hole approximately on the face plate. This makes it easier to true the work after the face plate is mounted on to the spindle.

The position of the bolts and clamps is very important, if a workpiece is to be clamped effectively.

If a number of duplicate pieces are to be machined, the face plate itself can be set up as a fixture, using parallel strips and stop blocks.

The application of the face plate with accessories in different set ups is shown in the sketches below. (Figs 4, 5 & 6)

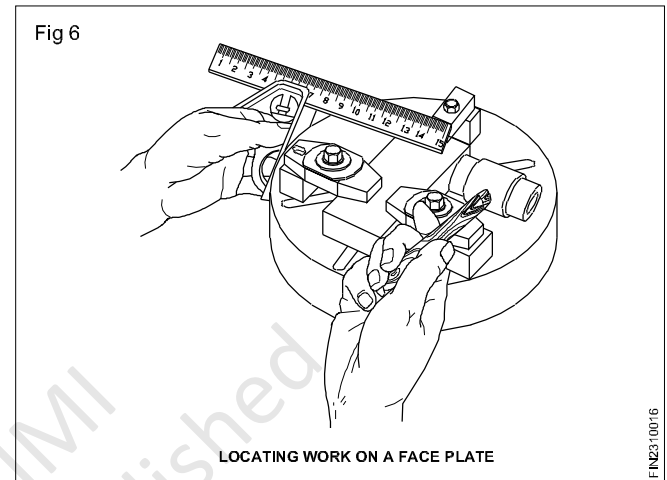
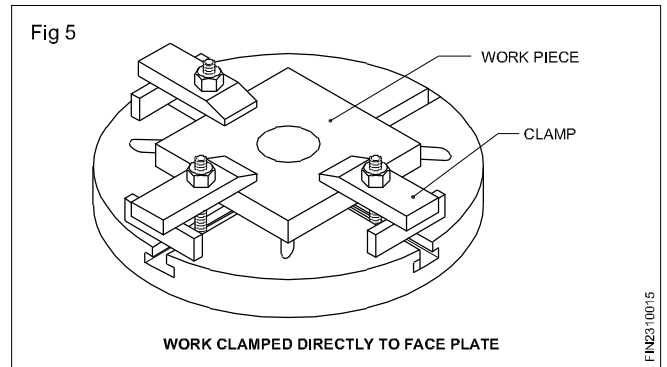
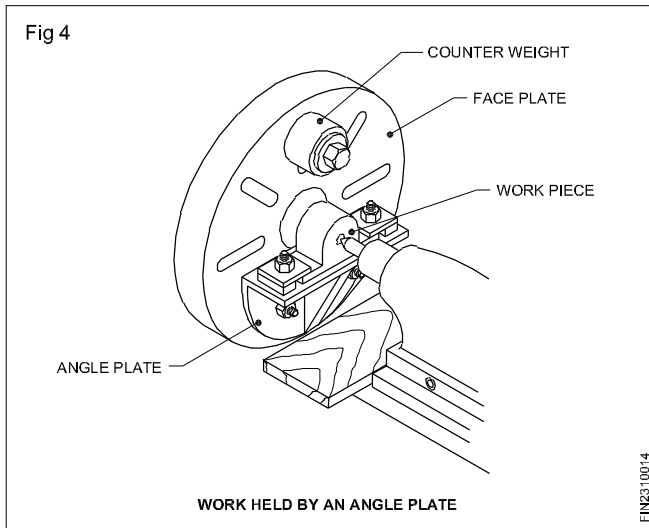

Drilling

Objectives: At the end of this lesson you shall be able to

- state the drilling process done in a lathe
- state the methods of holding the drill in the tail stock.

Lathe can be used for drilling

Before doing internal operation like boring, reaming and tapping. Although lathe is not a drilling machine time and effort are saved by using the lathe for drilling operations instead of changing the work to the other machines. Prior to drilling the end of the work piece on the lathe, the end face to be drilled must be spotted (center punched) and then centre drilled so that the drill will start properly

The head stock and tail stock spindle should be aligned for all drilling, reaming and tapping in order to produce a true hole.

Straight shank and taper shank drills can be held in the tailstock spindle as held in the drilling machine spindle using drill chuck sleeve and sockets. Since the tail stock spindle has the morse taper. (Fig 1)

Methods of holding drills in a tail stock (Fig 1)

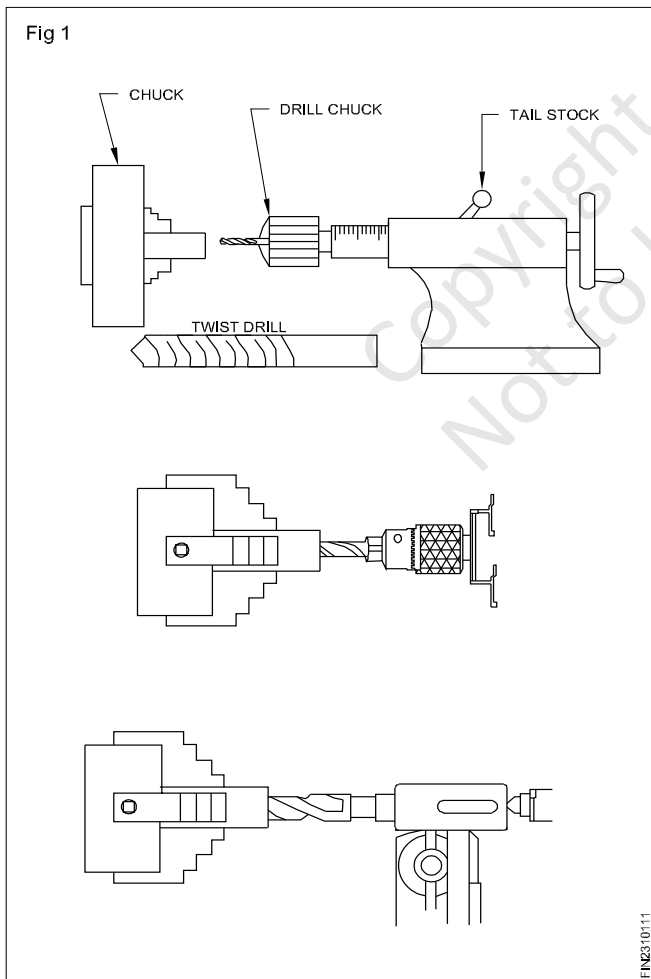

The different methods of holding drill in the tailshock are

- By using drill chuck (Fig 2)

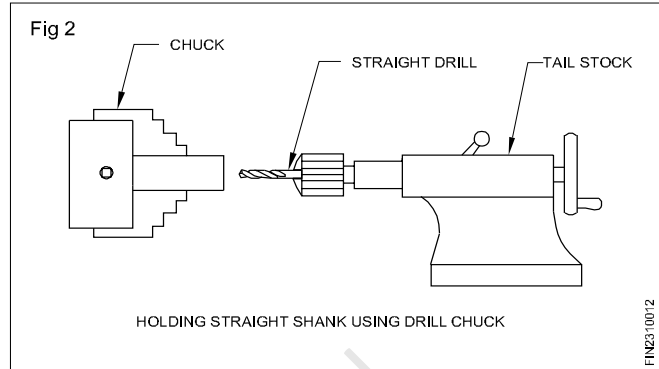

- By directly fitting in the tailstock spindle (Fig 3)

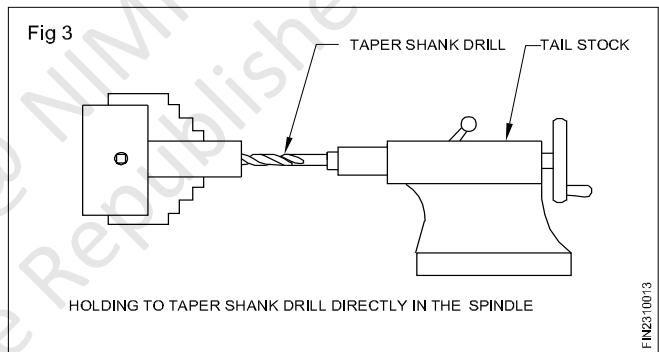

- By using drill sleeve (Fig 4)

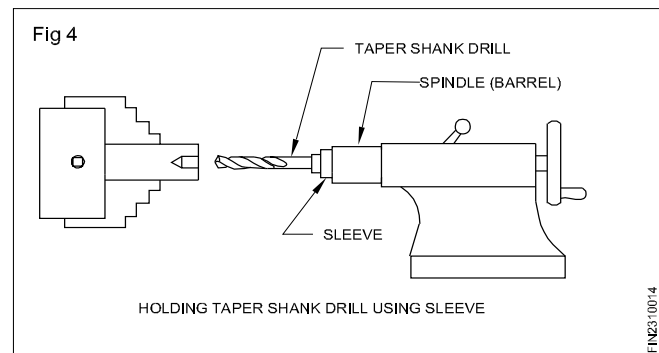

- By using drill socket (Fig 5)

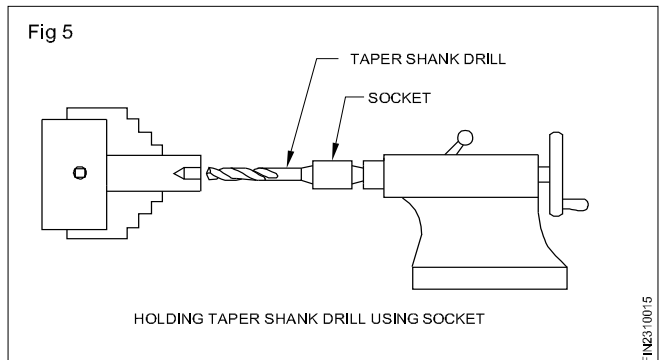

Boring & boring tools

Objectives: At the end of this lesson you shall be able to

- state the operation boring
- state the different types of boring tools.

Boring

Boring is the operation of enlarging and truing a hole produced by drilling, punching, casting or forging. Boring cannot originate a hole. Boring is similar to the external turning operation and can be performed in a lathe by the following two methods.

The work is revolved in a chuck or a face plate and the tool which is fitted to the tool post is fed into the work. This method is adopted for boring small sized works. A solid forged tool is used for boring small holes, whereas a boring bar with a tool bit attached to it is suitable for machining a large hole. The depth of cut is given by the cross-slide screw and the feed is effected by the longitudinal travel of the carriage. (Fig 1)

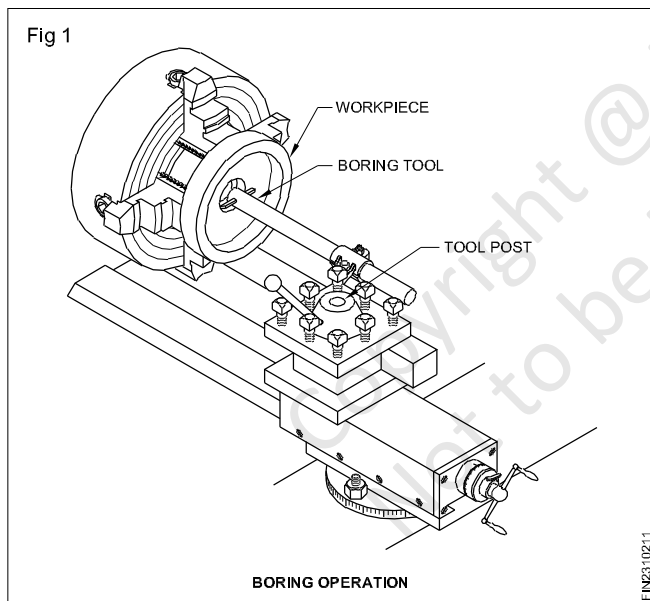

Types of boring tools

Solid forged tools

Solid forged boring tool is made from HSS with the end forged and ground. It resembles a left hand turning tool and the operation is performed from right to left. There are two types, solid boring tool (Fig 2) and solid forged bar in a tool-holder (Fig 3). They are used for light duty and on small diameter holes.

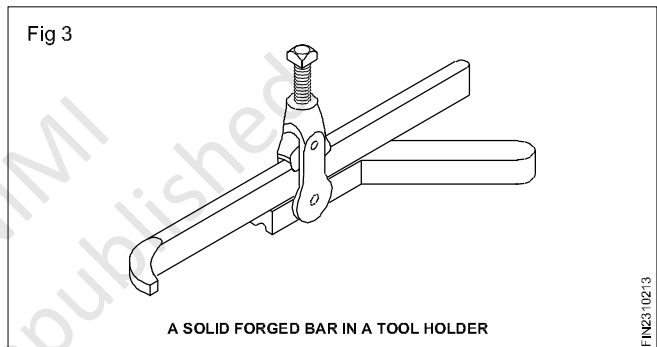
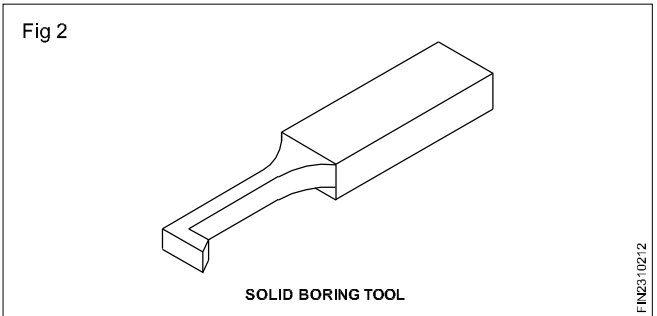

Advantages

- Regrinding is easy.
- Alignment is easy.
- Mounting and removal is easy.

Boring bars with inserted bits

Square and round tool bits made from HSS are inserted and fixed in the boring bar. The inserts can be set at an angle of 30°, 45° or 90° in the bar. It is used for heavier cuts than those made by the solid boring tool.

For plain boring, the inserts are set square to the axis of the bar. For facing the shoulder, or threading up to the shoulder, the inserts are set at an angle.

Boring bars used are of two types. (Fig 4)

- Plain boring bar
- End cap boring bar

Fig 4

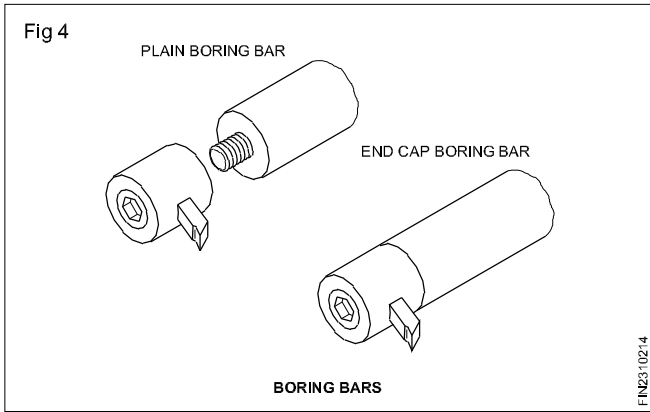

Advantages

Used for heavy duty boring operations.

Tool changing is faster.

Low cost

Boring tools can either be set square or at an angle quickly.

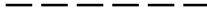

Copyright @ NIMI
Not to be Republished

Tool setting

Objectives: At the end of this lesson you shall be able to
 • **set the tool in the tool post for performing the operation.**

For optimum cutting, the effective rake angle and clearance angle of the clamped tool must be equal to the ground angles of the tool. This requires clamping of the tool to have its axis perpendicular to the lathe axis, with the tool tip at the workpiece centre. (Fig 1)

It is difficult to determine the effective angles of the tool when it is not set to the centre height.

The tool nose can be set to the work centre by means of a tool-holder with adjustable height. (Fig 1)

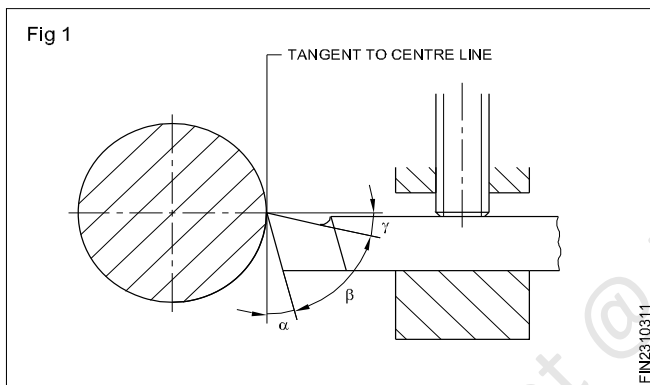

The tool nose can be set to the exact centre height by placing the tool in the tool post on the shims or packing strips. These packing strips should be preferably a little less in width than the width of the tool but should never be more. The length of these strips should be according to the shank length and the tool seating face of the tool post. (Fig 2)

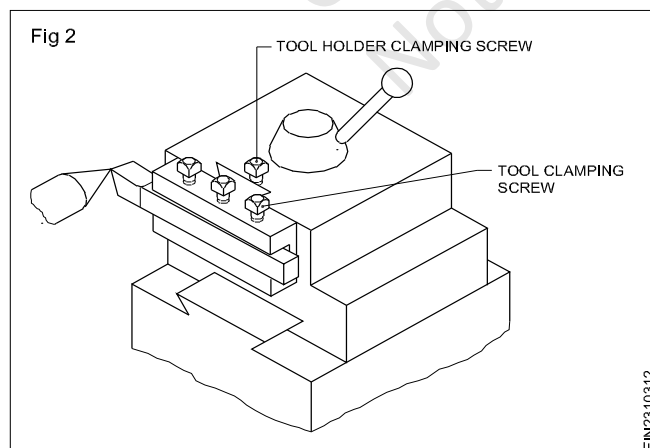

The procedure to follow is given below.

Clean the tool post seating face, and place the shims on the seating face.

Use a minimum number of shims for height adjustment.

Shims must be flushed with the edge of the seating face.

Place the tool in the tool post on the shims, with the rear butting against the wall of the seating face. (Fig 3)

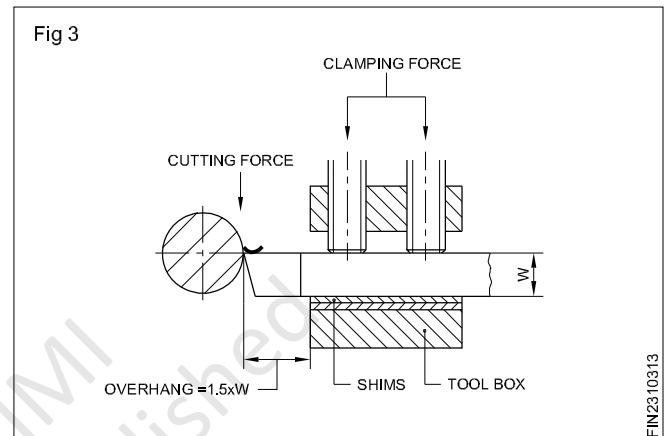

The unsupported length of the overhanging end of the turning tool should be kept to a minimum. As a rule, the overhanging length of tool is equal to the tool shank width x 1.5.

Tighten the tool with the centre screw of the tool post.

Check the centre height with a height setting gauge. (Fig 4)

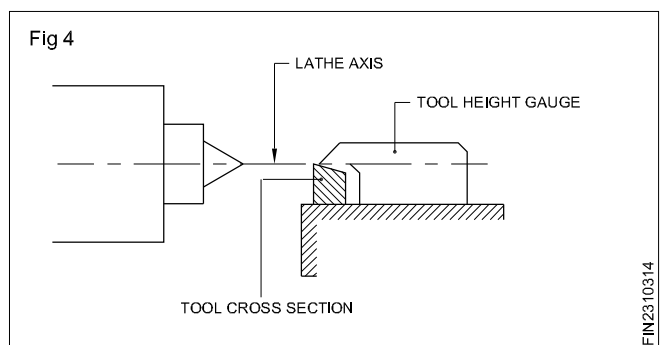

Remove or add shims and check the height when the tool is tightened by the centre screw.

Tighten the other two tool-holding screws alternate applying the same amount of pressure.

When both the screws have a full gripping pressure, tighten the centre screw fully.

Check once again with a tool height setting gauge.

Note: The gauge should be made according to the size of the machine. If a gauge is not available, use a surface gauge and set the pointer tip to the dead centre height fixed in the tallstock. Use this as the height to which the tool is to be set.

Parallel or straight turning

Objectives: At the end of this lesson you shall be able to

- define plain turning
- distinguish between the two stages of plain turning.

Plain turning (Parallel turning) (Fig 1)

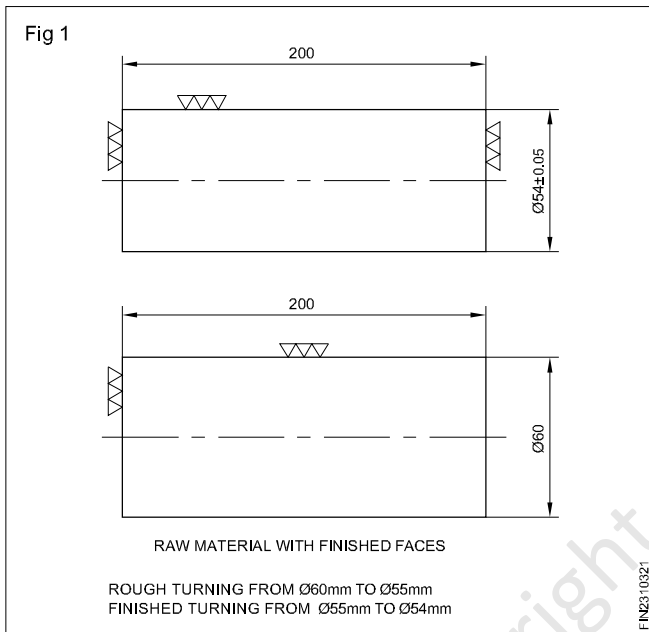

This operation involves removal of metal from the work and it has a cylinder for the full travel of the tool on the work, keeping the same diameter throughout the length.

Plain turning is done in two stages.

- Rough turning, using roughing tool or knife tool. (Fig 2)

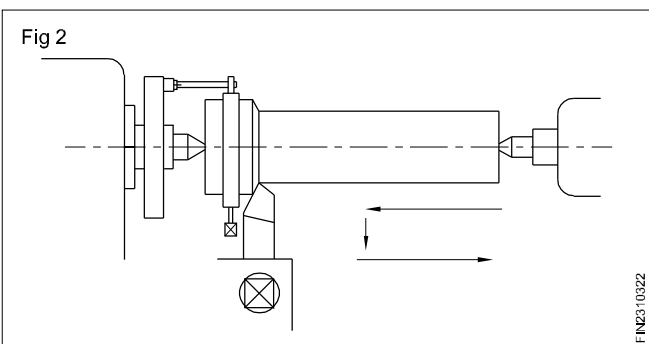

The spindle speed is calculated according to the material being turned, the tool material and the recommended cutting speed.

Rough turning

By rough turning the maximum amount of material is removed and the job is brought close to the required size,

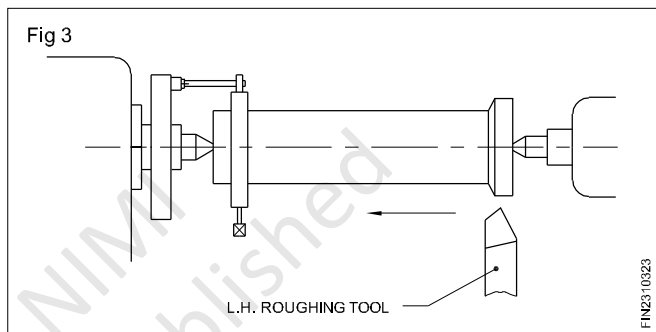

leaving sufficient metal for finishing. Surface finish and accuracy are not good. While rough turning, the spindle speed is less and the feed is more. A roughing tool or a knife tool is used.

While plain turning for roughing or finishing, long jobs are held between centres. It is necessary to change the ends to obtain a true parallel surface throughout the length. (Fig 3)

Finish turning

It is done, after the rough turning is completed to bring the size of the work to the required accuracy and good surface finish by removing the rough marks produced by the rough turning. For finish turning, the speed is higher (1 to 2 times more than for rough turning) and the feed is very less. A round nose finish turning tool or a knife with a larger nose radius than normal is used for finish turning.

- Finish turning using a finishing tool. (Fig 4)

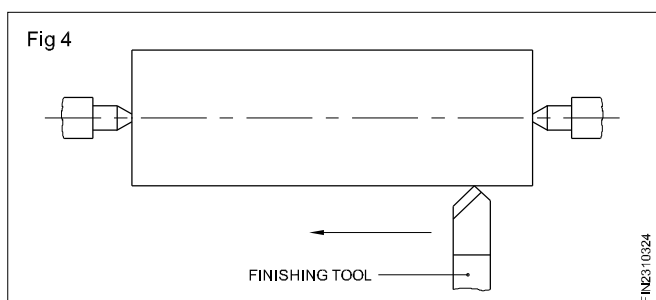

Step turning

Objective: At the end of this lesson you shall be able to

- define step turning

Step turning

It is an operation of producing various steps of different diameters in the work piece as shown in Fig 1 & 2. This operation is carried out in the similar way as plain turning.

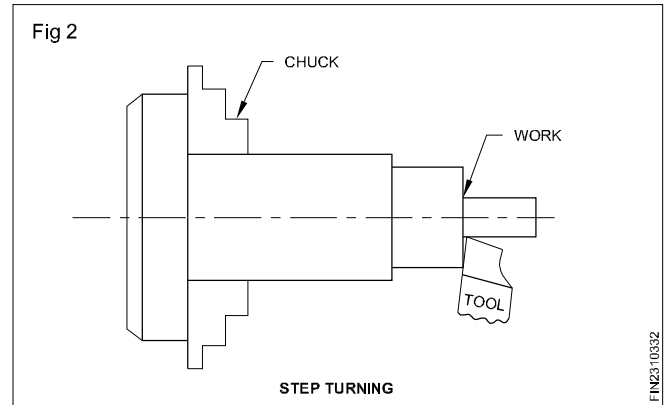
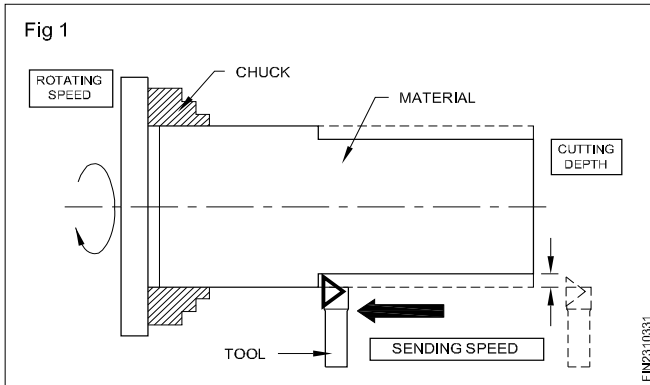

Grooving

Objectives: At the end of this lesson you shall be able to

- state what is grooving
- name the types of grooves
- state the specific uses of each type of groove.

Grooving

Grooving is the process of turning a grooved form or channel on a cylindrically turned workpiece. The shape of the cutting tool and the depth to which it is fed determine the shape of the groove.

Types of grooves

Square grooves

Square grooves are frequently cut at the end of a section to be threaded in order to provide a channel into which a threading tool may run. A square groove cut against a shoulder allows a matching part to fit squarely against the shoulder. (Fig 1)

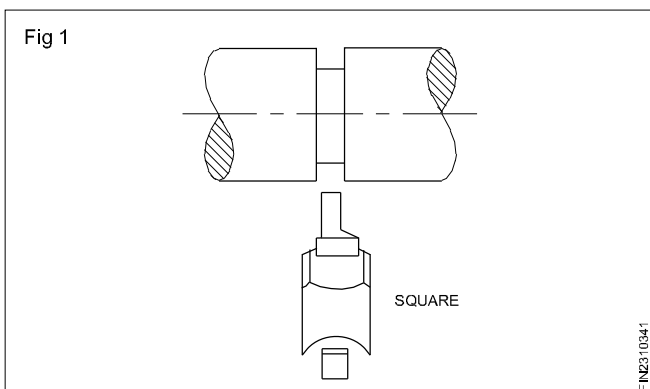

When a diameter is to be finished to size by grinding, a groove is generally cut against the shoulder to provide clearance for the grinding wheel and to ensure a square corner.

Square grooves are cut with a tool bit ground to the width of the square groove to be formed.

A square groove also serves the purpose of providing space for forks of shift levers in sliding gear assemblies.

Round groove

Round grooves serve the same purpose as square grooves. They are generally used on parts subjected to stress. The round groove eliminates the sharpness of the square corners and strengthens the part at the point where it tends to fracture. A tool bit with a round nose ground to the required radius is used to cut round grooves. (Fig 2)

'V' shaped groove

'V' shaped grooves are most commonly found on pulleys driven by 'V' belts. The 'V' shaped groove eliminates much of the slip which occurs in the other forms of the belt drive. A 'V' groove may also be cut at the end of a thread to provide a channel into which the threading tool may run. (Fig 3)

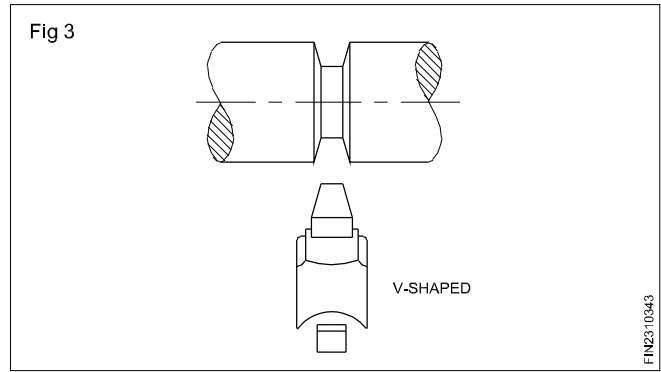
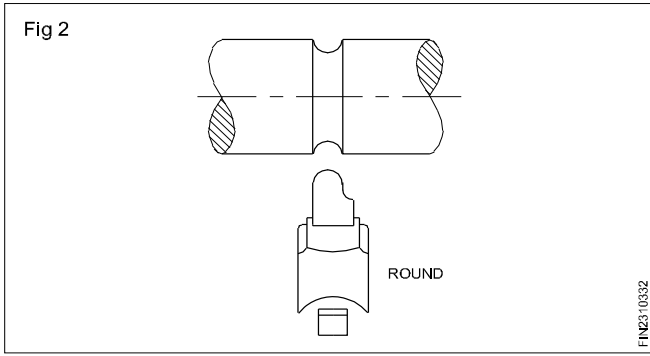

A tool bit ground to the desired angle is used to cut a shallow 'V' groove. Larger 'V' grooves such as those found on pulleys should be cut with the lathe compound rest to form each face of the groove individually.

Copyright @ NIMI
Not to be Republished

Tool post

Objectives: At the end of this lesson you shall be able to

- name the commonly used types of tool posts
- compare the features of different types of tool posts.

The tool post holds and firmly supports the tool or tools. The tool post is fitted on the top slide. (Fig 1)

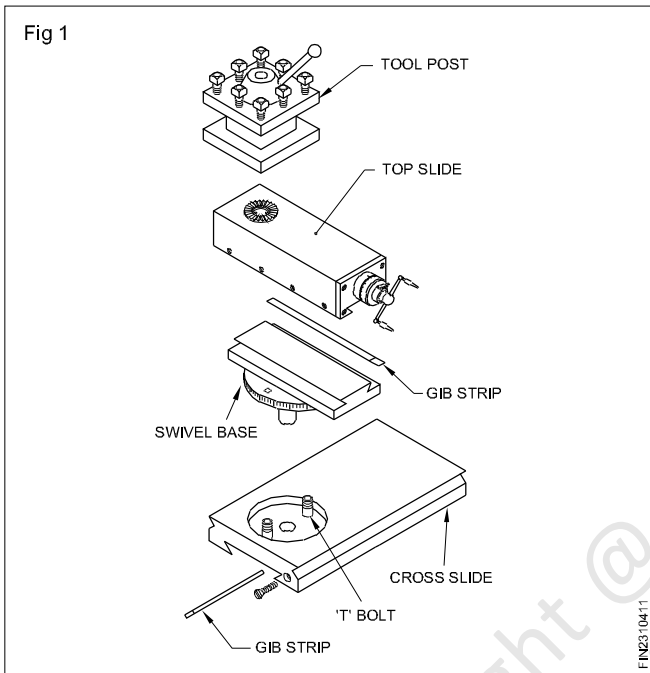

The commonly used types of tool posts are:

- American type tool post or single way tool post.
- Indexing type tool post or square tool post.
- Quick change tool post.

Single way tool post (Fig 2)

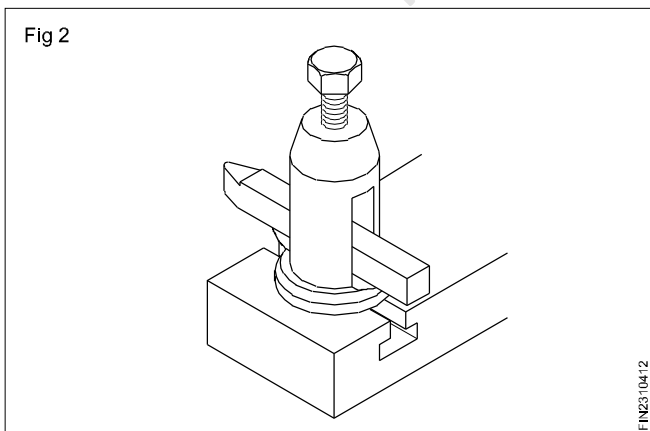

It consists of a circular tool post body and a pillar with a slot for accommodating the tool or tool-holder. A ring base, a rocker arm (boat piece) and a tool clamping screw complete the assembly of this type of tool post.

The tool is positioned on the boat piece and clamped. The centre height of the tool tip can be adjusted with the help of the rocker arm and the ring base. Only one tool can be fixed in this type of tool post. The rigidity of the tool is less as it is clamped with only one bolt.

Indexing type tool post (Fig 3)

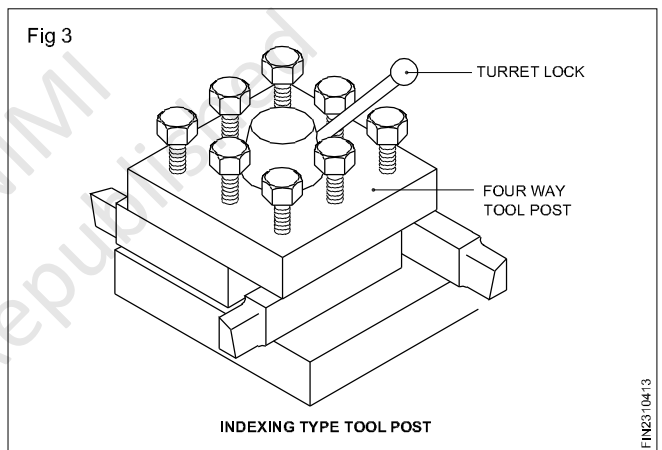

It is also called as square tool post or a four-way tool post. Four tools can be fixed in this type of tool posts, and any one can be brought into the operating position, and the square head is clamped with the help of the handle lever. By loosening the handle lever, the next tool can be indexed and brought in to the operating position. The indexing is manually.

The advantages are as follows.

Each tool is secured in the tool post by more than one bolt, and, therefore, the rigidity is more.

Frequent changing of the tool for different operations need not be done as all the four tools can be clamped at the same time.

The disadvantage is that skill is required to set the tools, and it takes more time to set to the centre height.

Quick change tool post (Fig 4)

Modern lathes are provided with this type of tool posts. Instead of changing the tools, the tool holder is changed in which the tool is fixed. This is expensive and requires a number of tool-holders. But it can be set to the centre height easily, and has the best rigidity for the tool.

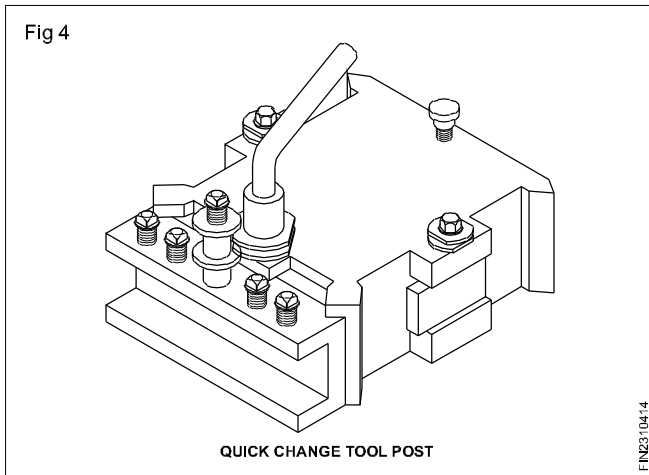

Copyright @ NIMI
Not to be Republished

Lathe operation - Knurling

Objectives: At the end of this lesson you shall be able to

- define knurling operation
- state the purpose of knurling
- list the different types of knurls and knurling patterns
- name the grades of knurls
- distinguish between the various types of knurling tool-holders.

Knurling (Fig 1)

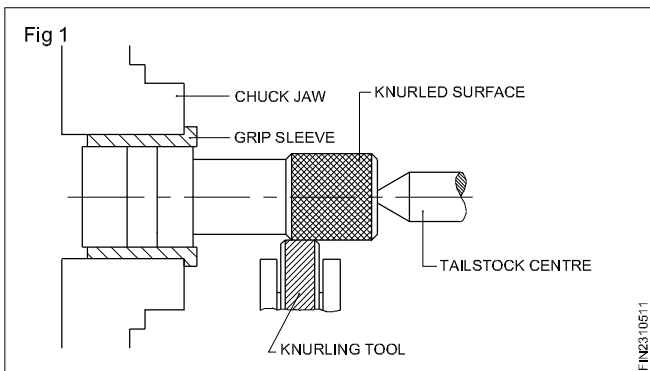

It is the operation of producing straight lined, diamond shaped pattern or cross lined pattern on a cylindrical external surface by pressing a tool called knurling tool. Knurling is not a cutting operation but it is a forming operation. Knurling is done at a slow spindle speed (1/3 the turning speed). However speed & feed given for knurling is to be divided according to the job material and the finish required.

Purpose of knurling

The purpose of knurling is to provide:

- A good grip and make for positive handling.
- Good appearance
- For raising the diameter to a small range for assembly to get a press fit.

Types of knurls and knurling patterns

The following are the different types of knurling patterns.

Diamond knurling, Straight knurling, Cross knurling, Concave knurling and Convex knurling.

Diamond knurling (Fig 2)

It is a knurling of diamond shaped pattern. It is done by using a set of rolls. One roller has got right hand helical teeth and the other has left hand helical teeth.

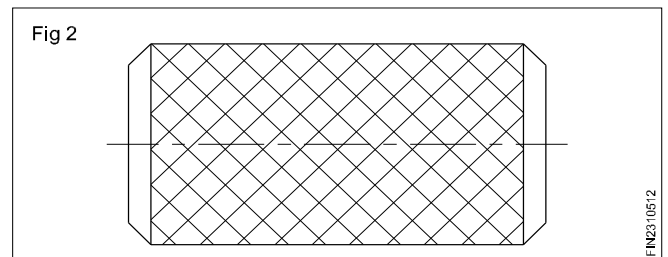

Straight knurling (Fig 3)

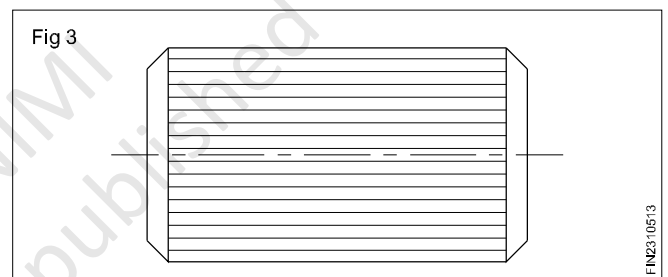

It is a knurling of straight lined pattern. This is done by using either a single roller or a double roller with straight teeth.

Cross knurling (Fig 4)

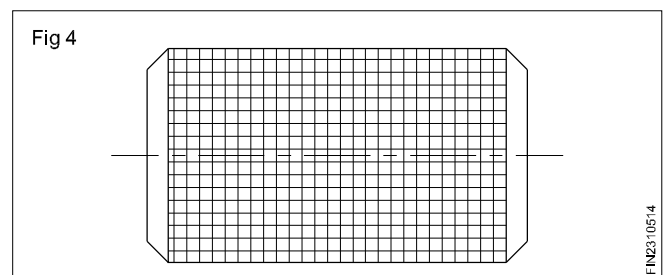

It is a knurling having a square shaped pattern. It is done by a set of rollers, one having straight teeth the other having teeth at right angles to the axis of knurl.

Concave knurling (Fig 5)

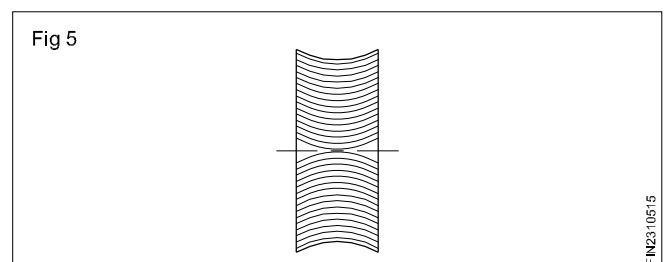

This is done by a convex knurl on a concave surface. This is done only by plunging the tool. The tool should not be moved longitudinally. The length of the knurling is limited to the width of the roller.

Convex knurling (Fig 6)

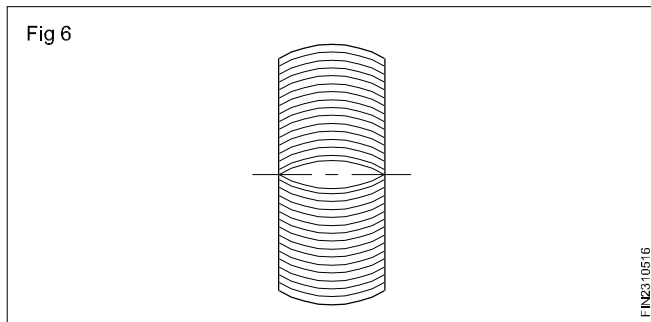

This is done by using a concave knurl on a convex surface. This is also done by plunging the tool.

Grades of knurling (Fig 7)

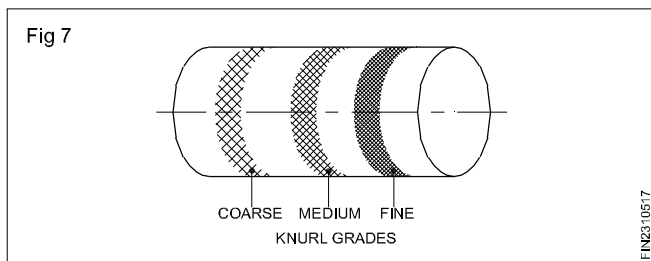

Knurling can be done in three grades.

Coarse knurling, Medium knurling and Fine knurling

Coarse knurling is done by using coarse pitched knurls of 1.75 mm pitch. (14 TPI)

Medium knurling is done by using medium pitched knurls of 1.25 mm pitch. (21 TPI)

Fine knurling is done by using fine pitched knurls of 0.75 mm pitch. (33 TPI)

Types of knurling tool-holders

The different types of knurling tool-holders are:

- Single roller knurling tool-holders (parallel knurling tool-holders)
- Knuckle joint type knurling tool-holders
- Revolving type knurling tool-holders (universal knurling tool-holders).

A knurling tool-holder has a heat-treated steel shank and hardened tool steel knurls. The knurls rotate freely on hardened steel pins.

Single roller knurling tool-holder (Fig 8)

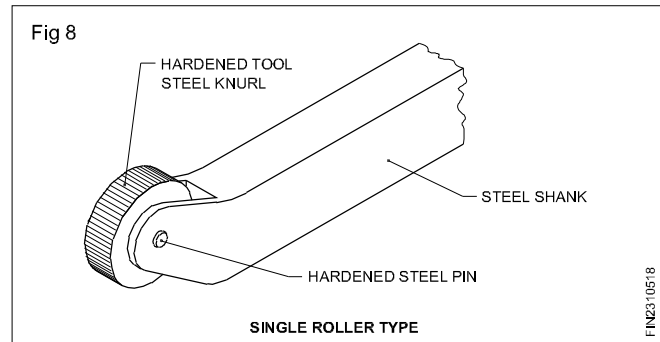

It has only one single roller which produces a straight lined pattern.

Knuckle joint type knurling tool-holders (Fig 9)

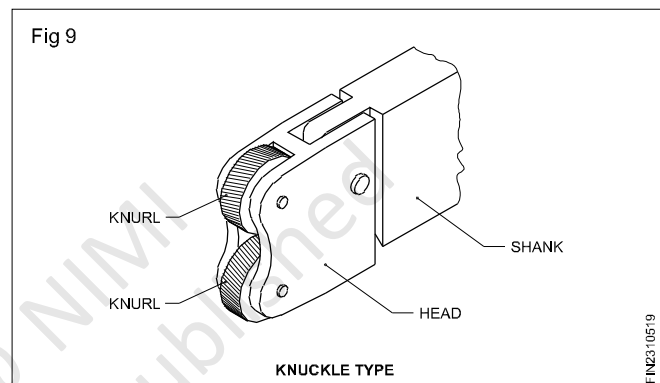

This tool holder has a set of two rollers of the same knurling pitch. The rollers may be of straight teeth or helical teeth. It is self-centering.

Revolving head knurling tool (Fig 10)

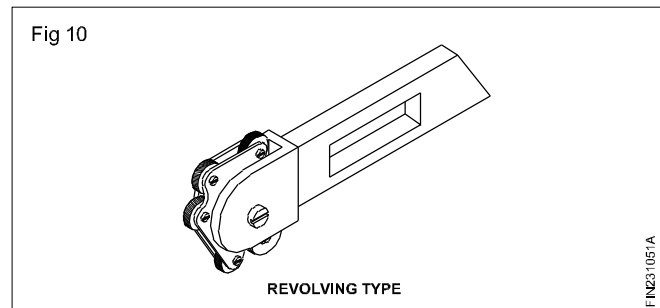

This tool-holder is also called a universal knurling tool-holder. It is fitted with 3 pairs of rollers having coarse, medium and fine pitches. These are mounted on a revolving head which pivots on a hardened steel pin. It is also self-centering.

Difference between different types of knurling tool-holders

Single roller	Knuckle joint	Revolving type
Only one roller is used	A pair of rollers are used	Three pairs of rollers are used
Only one pattern of knurling can be produced with this type of knurling tool-holder	Cross of diamond knurling pattern can be produced	Knurling patterns of different pitches can be produced
It is not self-centering	It is self-centering	It is self-centering

Copyright @ NIMI
Not to be Republished

Standard tapers

Objectives: At the end of this lesson you shall be able to

- define a taper
- state the uses of tapers
- state the method of expressing tapers
- state the methods to be adopted while specifying tapers
- distinguish between the features of self-holding and self-releasing tapers
- name the different types of self-holding tapers and state their features
- state the features of self-releasing tapers
- state the features of pin taper and keyway taper.

Definition of Taper

Taper is a gradual increase or decrease in the dimension along its length of the job.

Tapers are used for:

- Self-alignment/location of components in an assembly.
- Assembling and dismantling parts easily.
- Transmitting drive through assembly.

Tapers have a variety of applications in engineering assembly work.(Figs 1,2 & 3)

Tapers of components are expressed in two ways.

- Degree of arc (Fig 4)
- Gradient (Fig 5)

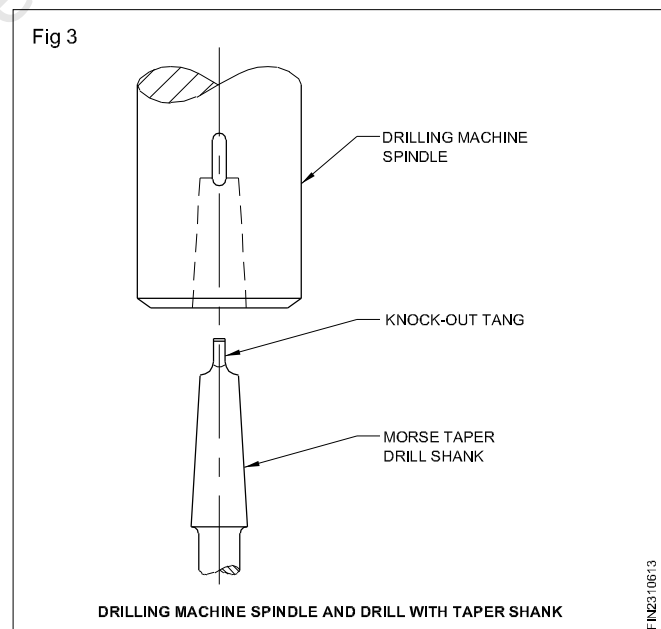
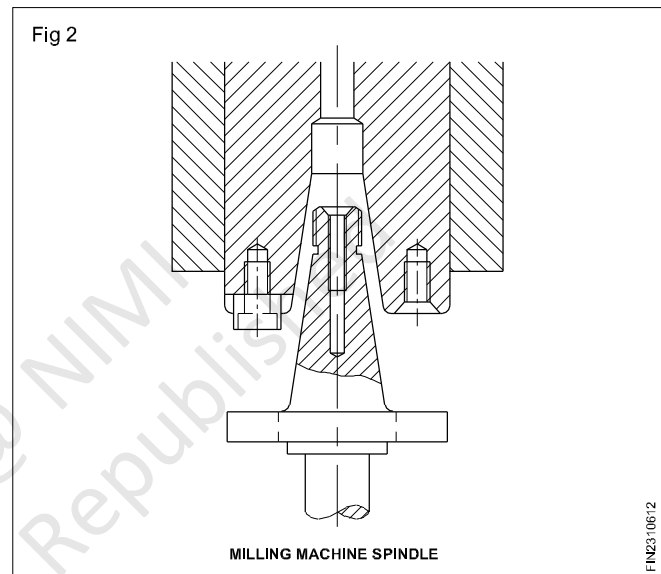
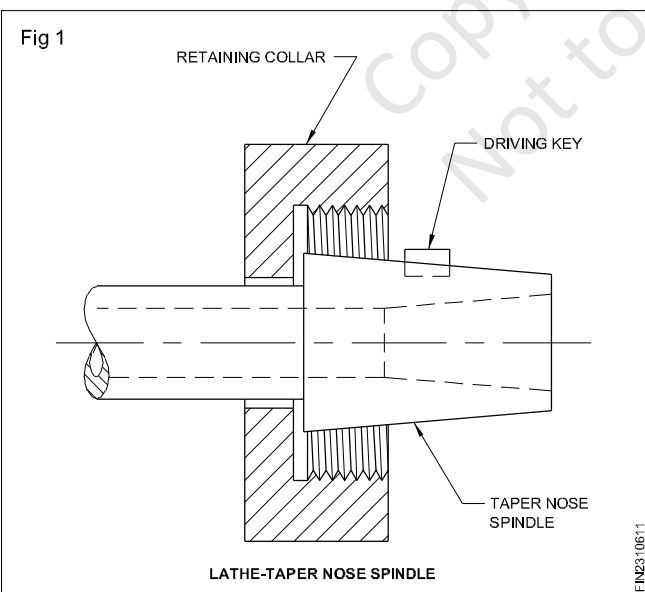

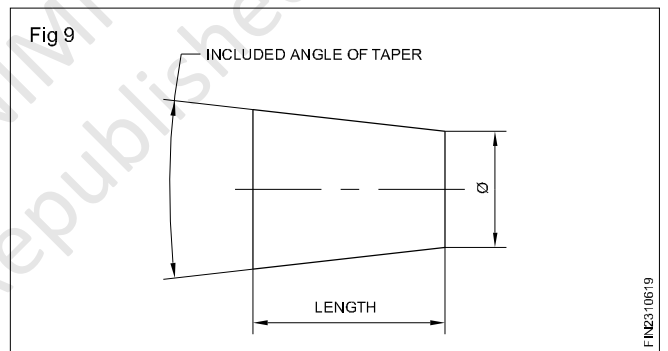
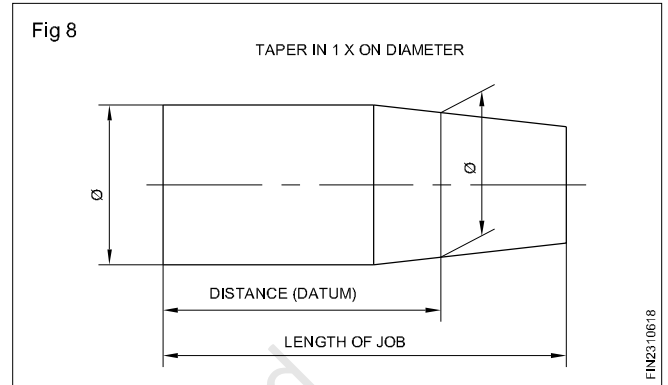
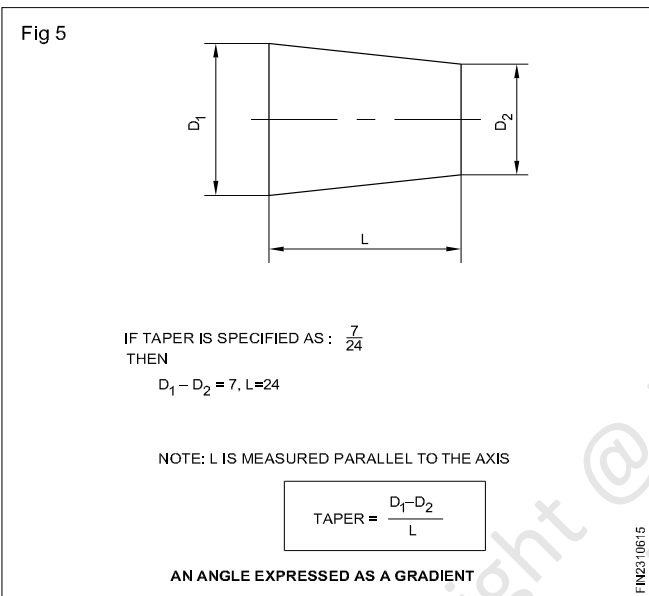
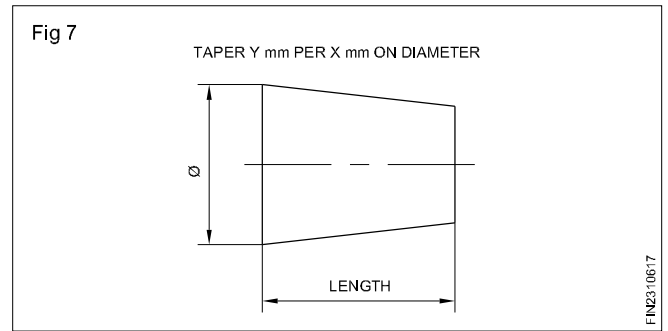
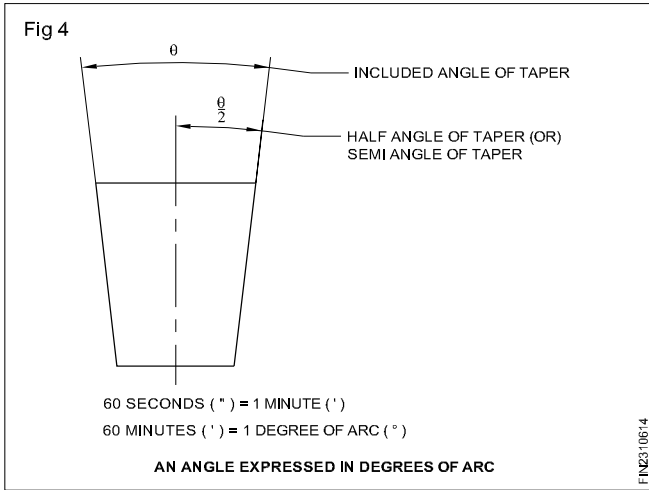

The method adopted for expressing tapers depends on:

- The steepness of the tapers
- The method adopted for measuring.

Specification of tapers

While specifying taper in drawings it should indicate the:

- Angle of the taper
- Size of the component. (Figs 6,7, 8 & 9)

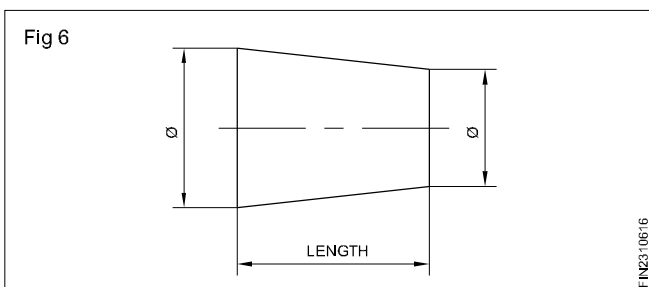

Standard tapers

Tapers for tool-holding

Two types of tapers are used for tool-holding on machines.

- Self-holding tapers
- Self-releasing tapers

Self-holding tapers

Self-holding tapers have less taper angle. These are used for holding and driving cutting tools like drills, reamers etc. without any locking device. (Fig 10)

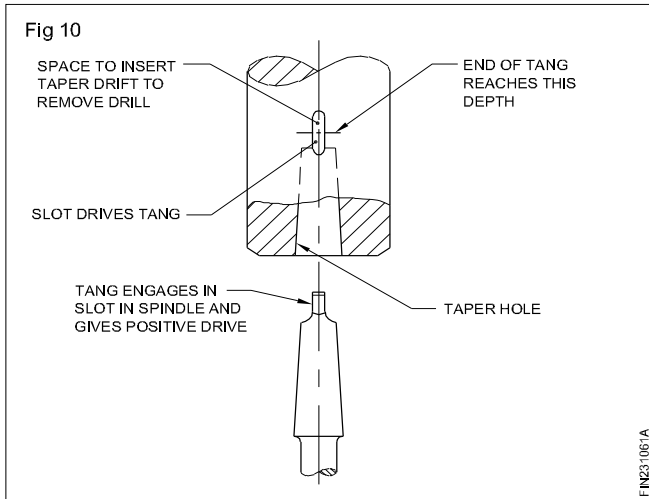

The standard tapers used for this are:

- The metric taper
- The morse taper.

Metric taper

The taper on diameter is 1:20. The commonly used shank sizes in metric tapers are metric 4, 6, 80, 100, 120, 160 and 200. The shank size indicating the metric taper is the diameter at D. (Fig 11)

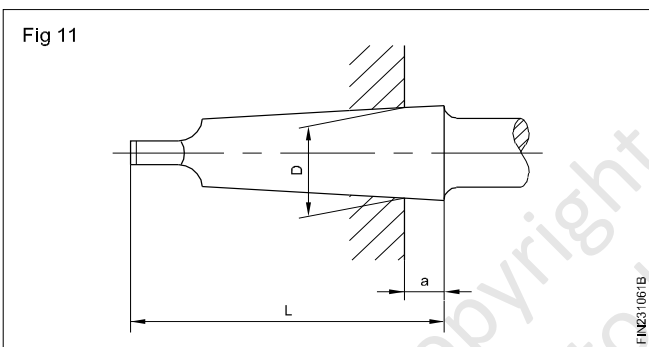

Morse taper

The commonly used taper shank sizes are:

- 0, 1, 2, 3, 4, 5 and 6.

The taper is varying according to the size of the Morse taper. It varies from 1:19.002 to 1:20.047.

Self-releasing 7/24 taper (Fig 12)

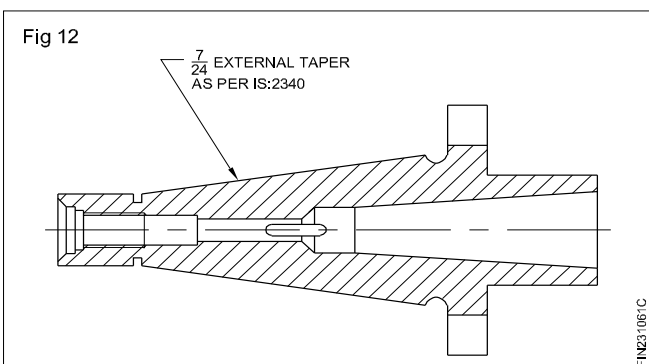

Spindle noses and arbors used on milling machines are usually provided with self-releasing tapers. The standard self-releasing taper is 7/24. This is a steep taper which helps in the correct location and release of the components in the assembly. This taper does not drive the mating component in the assembly. For the purpose of driving, additional features are provided.

The commonly used 7/24 taper sizes are: 30,40,45,50 and 60.

The taper of a 7/24 taper of No.30 will have a maximum diameter of (D) 31.75 mm and No.60, 107.950 mm. All other sizes fall within this range.

Tapers used in other assembly work

A variety of tapers are used in engineering assembly work. The most common ones are:

- pin taper
- key and keyway taper.

Pin taper

This is the taper used for taper pins used in assembly. (Fig 13)

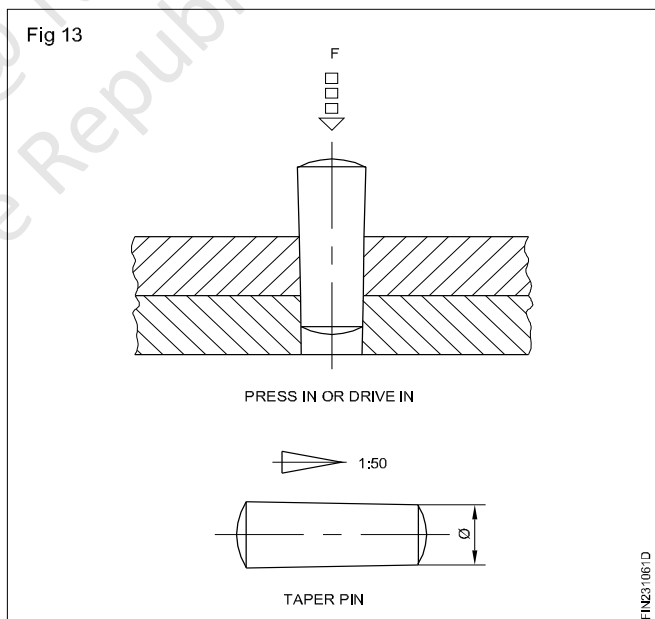

The taper is 1:50.

The diameter of taper pins is specified by the small diameter.

Taper pins help in assembling and dismantling of components without disturbing the location.

Key and keyway tapers

This taper is 1:100. This taper is used on keys and keyways. (Figs 14 and 15)

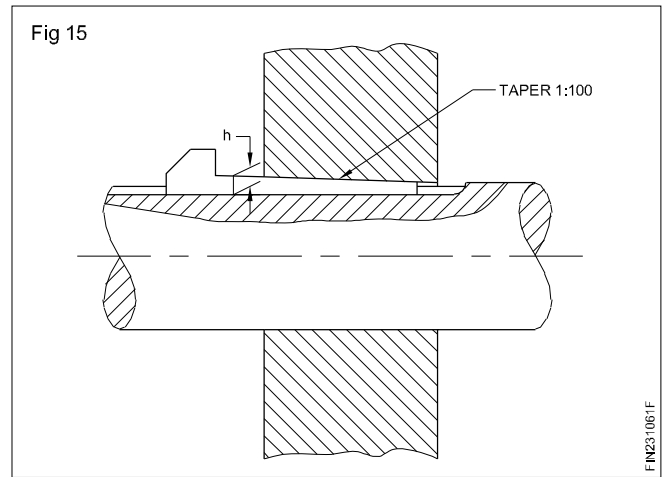
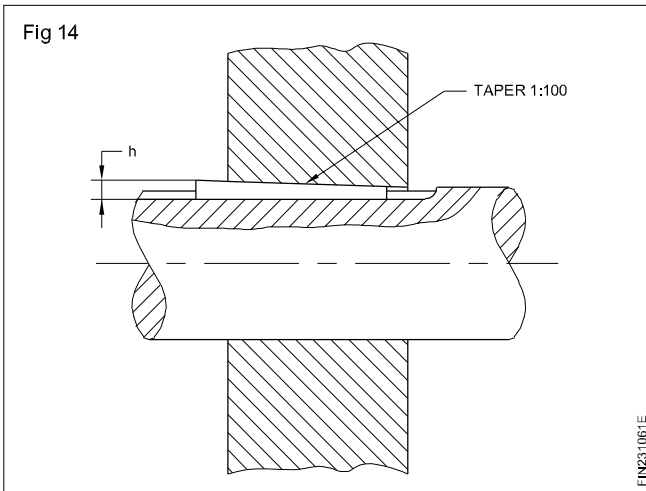

Note: For further information about the tapers used for special application refer to: IS: 3458 - 1981.

Copyright @ NIMI
Not to be Republished

Screw thread

Objectives: At the end of this lesson you shall be able to

- define screw thread
- state the use of screw thread.

Definition

Thread is a ridge of uniform cross-section which follows the path of a helix around the cylinder or cone, either externally or internally. (Fig 1)

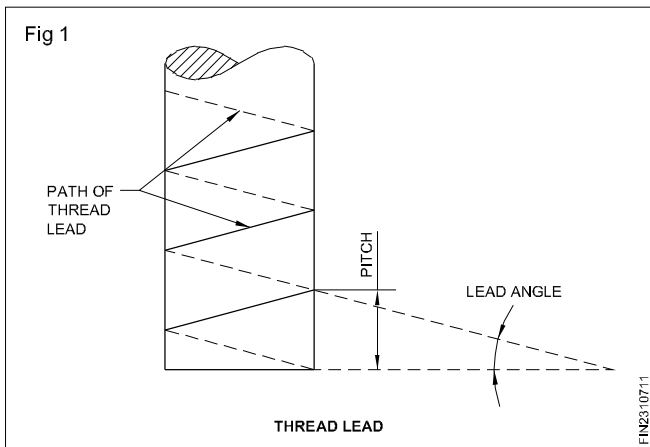

Helix is a type of curve generated by a point which is moving at a uniform speed around the cylinder or cone and at the same time, moves at a uniform speed parallel to the axis. (Fig 1)

Uses of Screw threads

Screw threads are used

- As fasteners to hold together and dismantle components when needed. (Fig 2)

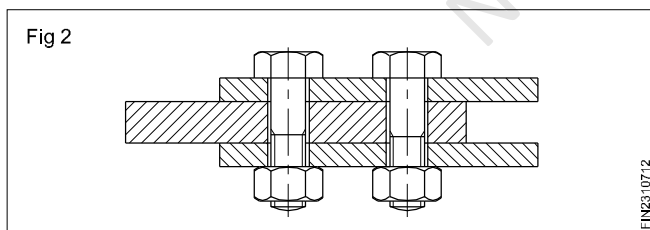

- To transmit motion on machines from one unit to another. (Fig 3)

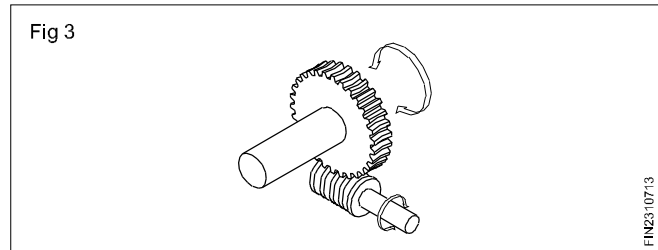

- To make accurate measurements. (Fig 4)

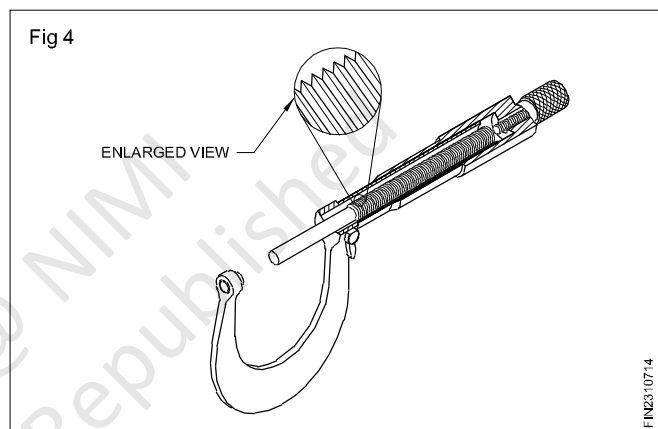

- To apply pressure. (Fig 5)

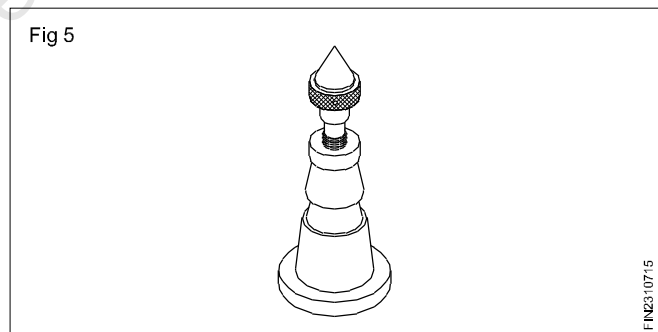

- To make adjustments. (Fig 6)

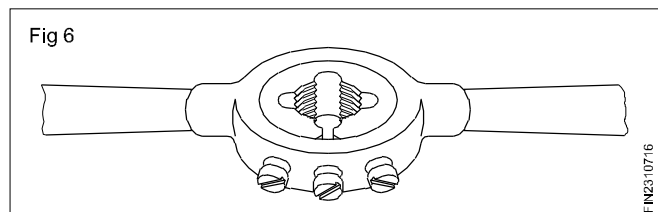

Square, worm, buttress and acme threads

Objectives: At the end of this lesson you shall be able to

- identify square thread and specify its uses
- state the relationship between the pitch and the other elements of square threads
- identify the modified square thread and its applications
- identify the different forms of trapezoidal threads and their uses
- state the relationship between the pitch and the other elements of all the different forms of trapezoidal threads.

Square and trapezoidal threads

Square and trapezoidal threads have more cross-sectional area than 'V' threads. They are more suitable to transmit motion or power than 'V' threads. They are not used for fastening purposes.

Square thread

In this thread the flanks are perpendicular to the axis of the thread. The relationship between the pitch and the other elements is shown in Fig 1.

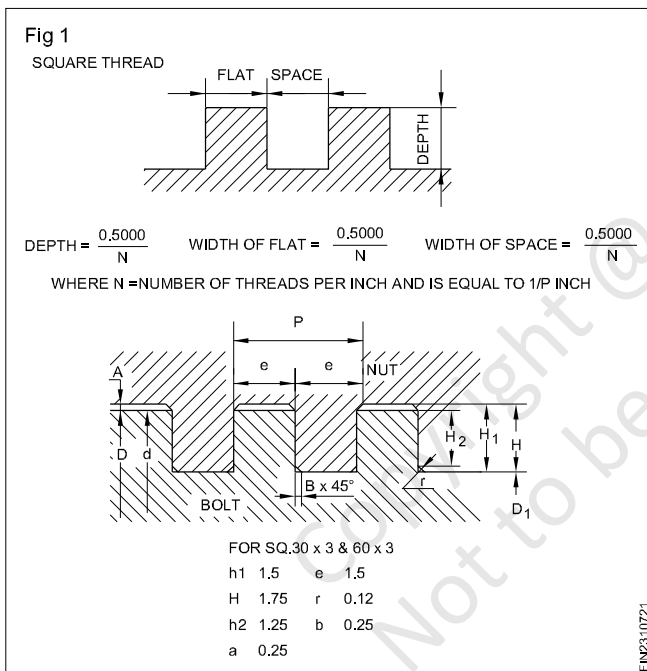

Square threads are used for transmitting motion or power. Eg. screw jack, vice handles, cross-slide and compound slide, activating screwed shafts.

Designation

A square thread of nominal dia. 60mm and pitch 9mm shall be designated as Sq. 60 x 9 IS: 4694-1968. The dimensions a, b, e, p, H₁, h₁, h₂ & d₁ are changed as per thread series (fine, normal & coarse).

Modified square thread

Modified square threads are similar to ordinary square threads except for the depth of the thread. The depth of thread is less than half pitch of the thread. The depth varies according to the application. The crest of the thread is chamfered at both ends to 45° to avoid the formation of burrs. These threads are used where quick motion is required.

Trapezoidal threads

These threads have a profile which is neither square nor 'V' thread form and have a form of trapezoid. They are used to transmit motion or power. The different forms of trapezoidal threads are:

- Acme thread
- Buttress thread
- Saw-tooth thread
- Worm thread.

Acme thread (Fig 2)

This thread is a modification of the square thread. It has an included angle of 29°. It is preferred for many jobs because it is fairly easy to machine.

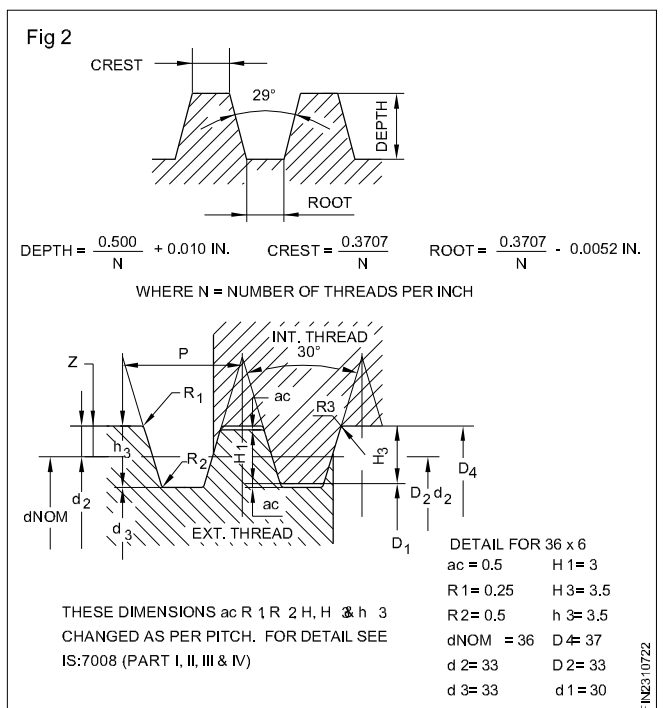

Acme threads are used in lathe lead screws. This form of thread enables the easy engagement of the half nut. The metric acme thread has an included angle of 30°. The relationship between the pitch and the various elements is shown in the figure.

Buttress thread (Fig 3)

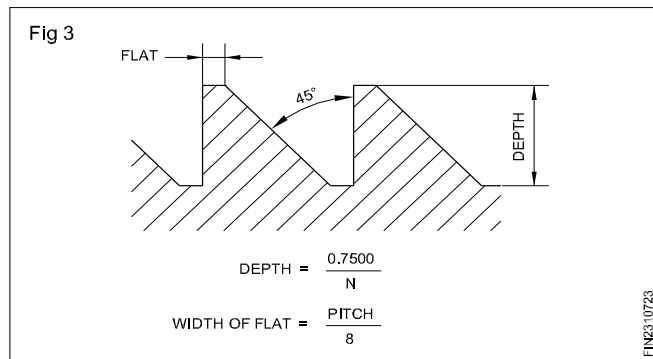

In buttress thread one flank is perpendicular to the axis of the thread and the other flank is at 45°. These threads are used on the parts where pressure acts at one flank of the thread during transmission. Figure 3 shows the various elements of a buttress thread. These threads are used in power press, carpentry vices, gun breeches, ratchets etc.

Buttress thread as per B.I.S. (Fig 4)

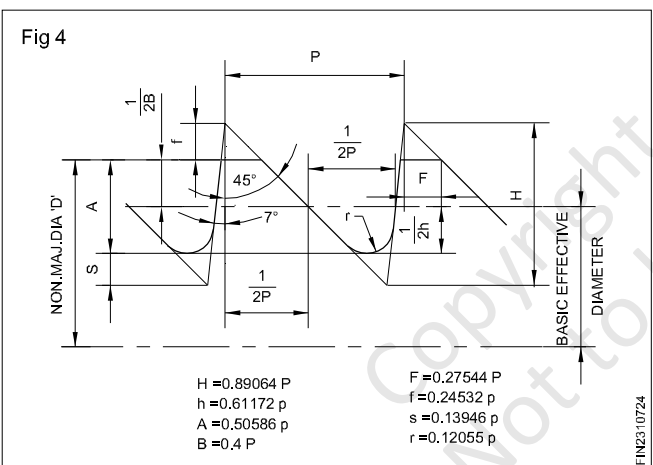

This is a modified form of the buttress thread. Figure 4 shows the various elements of the buttress thread. The bearing flank is inclined by 7° as per B.I.S. and the other flank has a 45° inclination.

Saw-tooth thread as per B.I.S. 4696

This is a modified form of buttress thread. In this thread, the flank taking the load is inclined at an angle of 3°, whereas the other flank is inclined at 30°. The basic profile of the thread illustrates this phenomenon. (Fig 5) The proportionate values of the dimensions with respect to the pitch are shown in Figs 6 and 7.

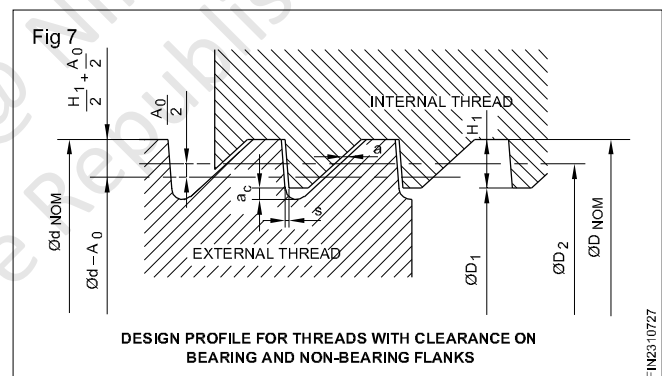
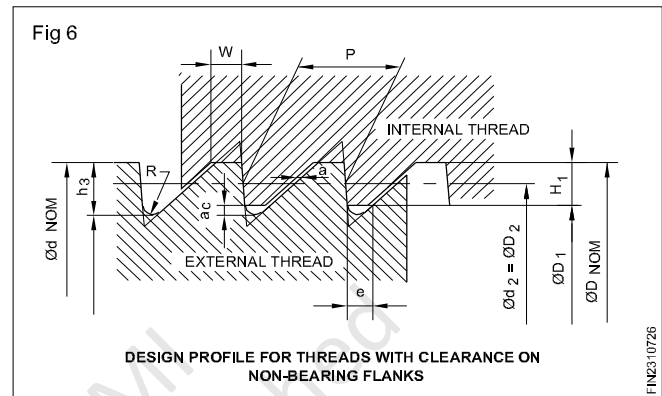
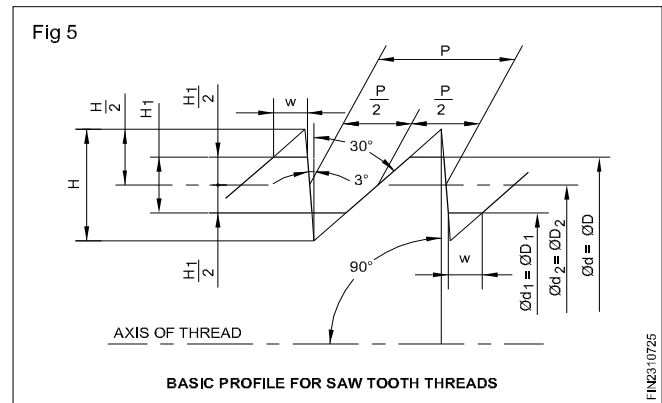

The equations associated with the dimensions indicated in the two figures (Figs 6 and 7) are given below.

$$H_1 = 0.75 P$$

$$h_3 = H_1 + a_c = 0.86777 P$$

$$a = 0.1 \bar{p} \text{ (axial play)}$$

$$a_c = 0.11777 P$$

$$W = 0.26384 P$$

$$e = 0.26384 P - 0.1 \bar{p} = W - a$$

$$R = 0.12427 P$$

$$D_1 = d - 2 H_1 = d - 1.5 P$$

$$d_3 = d - 2 h_3$$

$$d_2 = D_2 = d - 0.75 P$$

$S = 0.31499 A_o$, where A_o = basic deviation (= upper deviation) for external thread in the pitch diameter.

Worm thread

This is similar to acme thread in shape but the depth of thread is more than that of acme thread. This thread is cut on the worm shaft which engages with the worm wheel. Figure 8 shows the elements of a worm thread.

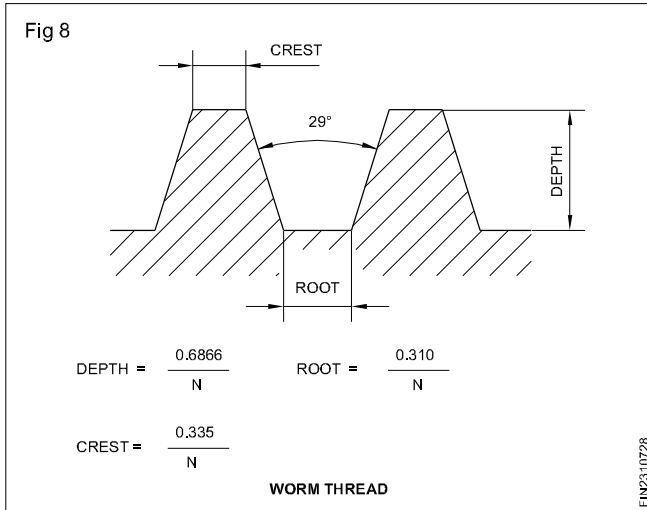

The worm wheel and worm shaft are used in places where motion is to be transmitted between shafts at right angles. It also gives a high rate of speed reduction. The worm wheel is generally cut by diametral pitch (D.P) or module pitch cutters. Diametral pitch (D.P) is the ratio between the number of teeth to the pitch diameter (P.D.) of the gear. Module is the ratio between the pitch diameter of the gear and the number of teeth of the gear.

The linear pitch of the worm thread must be equal to the circular pitch of the worm gear. When the worm gear is of D.P. then the linear pitch of the worm thread in mesh is equal to p/DP . When the worm gear is of module teeth, then the linear pitch of the worm thread is equal to module $\times p$. In some of the lathes, a chart illustrates the position of levers of the quick change gearbox together with the change gear connections for cutting D.P. or module worm threads.

Knuckle threads

The shape of the knuckle thread is not trapezoidal but it has a rounded shape. It has limited application. The figure shows the form of knuckle thread. It is not sensitive against damage as it is rounded. It is used for valve spindles, railway carriage couplings, hose connections etc. (Fig 9)

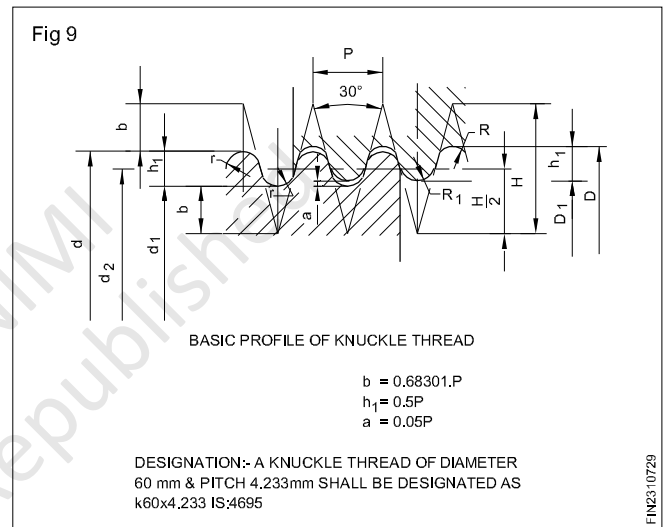

Principle of cutting screw thread in centre lathe

Objectives: At the end of this lesson you shall be able to

- state the principle of thread cutting by a single point tool
- list the parts involved in the thread cutting mechanism and state their functions
- derive formula for change gear calculation.

Principle of thread cutting

The principle of thread cutting involves producing a uniform helical groove on a cylindrical or conical surface by rotating the job at a constant speed, and moving the tool longitudinally at a rate equal to the pitch of the thread, per revolution of the job.

The cutting tool moves with the lathe carriage by the engagement of a half nut with the lead screw. The shape of the thread profile on the work is the same as that of the tool ground. The direction of rotation of the lead screw determines the hand of the thread being cut.

Parts involved in thread cutting

Figures 1 & 2 illustrate how the drive is transmitted from the spindle to the lead screw through a change gear arrangement. From the lead screw the motion is transmitted to the carriage by engaging the half nut with the lead screw.

Derivation of the formula for change gears

Example

CASE 1 : To cut 4 mm pitch (lead) thread on the job in a lathe having a lead screw of 4 mm pitch.

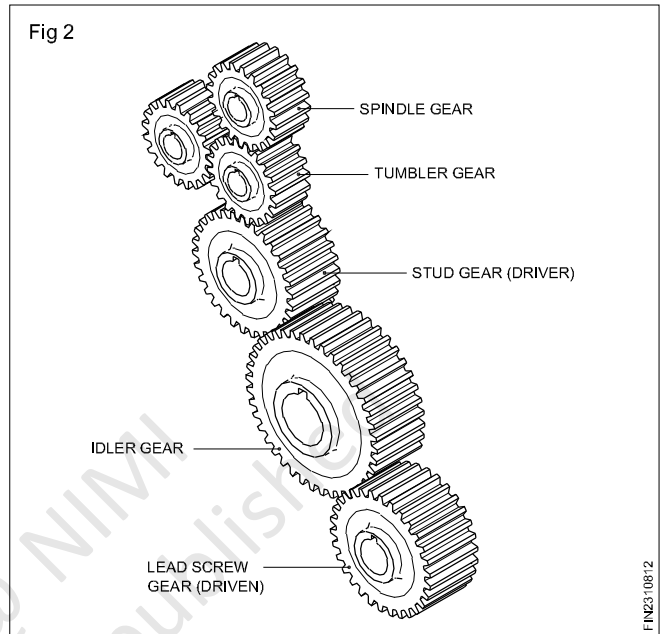

When the job rotates once, the lead screw should make one revolution to move the tool by 4 mm. Hence, if the stud gear (Driver) has a 50 teeth wheel, the lead screw should be fixed with a gear of 50 teeth (Driven) to get the same number of revolutions as the spindle. (Fig 3)

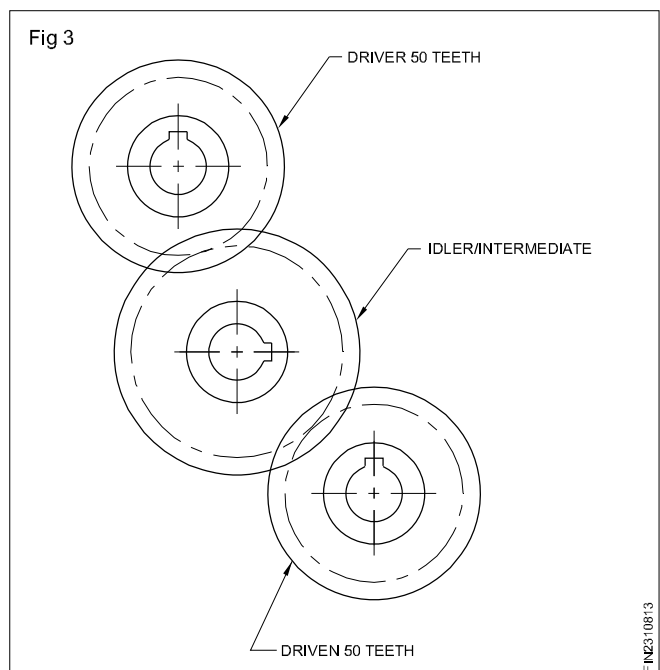
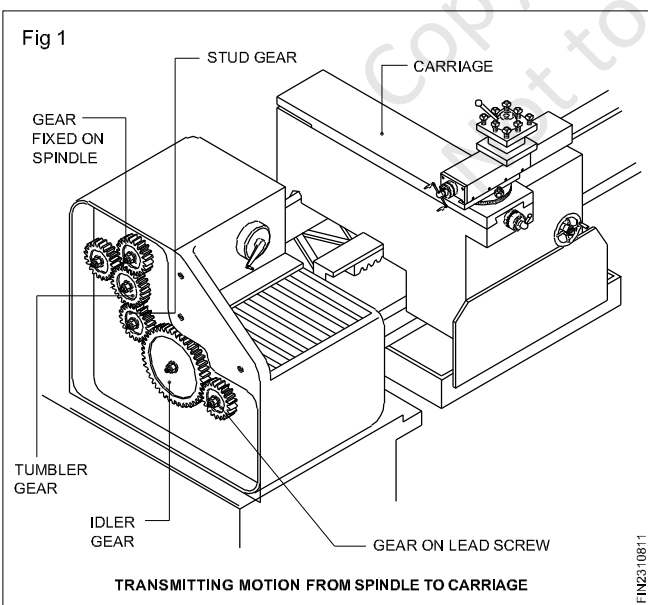

CASE 2 : To cut 2 mm pitch threads instead of 4 mm in the same lathe.

When the job makes one rotation, the lead screw should rotate 1/2 revolution so that the lead screw rotation is slower. Therefore, the driven wheel (lead screw gear) should be of 100 teeth if the driver (stud gear) is of 50 teeth. (Fig 4)

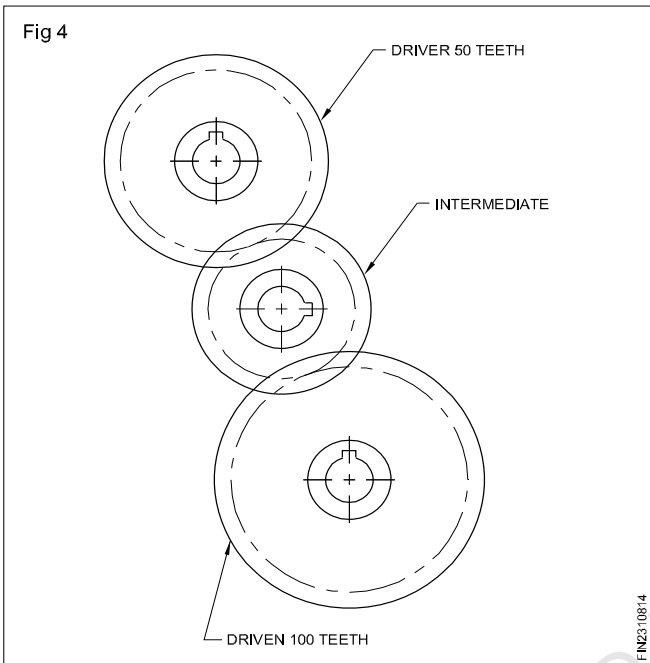

CASE 3 : If we have to cut a 8 mm pitch thread on a job, with a 4mm lead screw pitch, the tool should move 8 mm per revolution of the job. The lead screw should rotate 2 revolutions when the job makes one rotation, making the L S to run twice as fast as the spindle. So the driven wheel (lead screw gear) should be of 25 teeth if the driver wheel is of 50 teeth. (Fig 5)

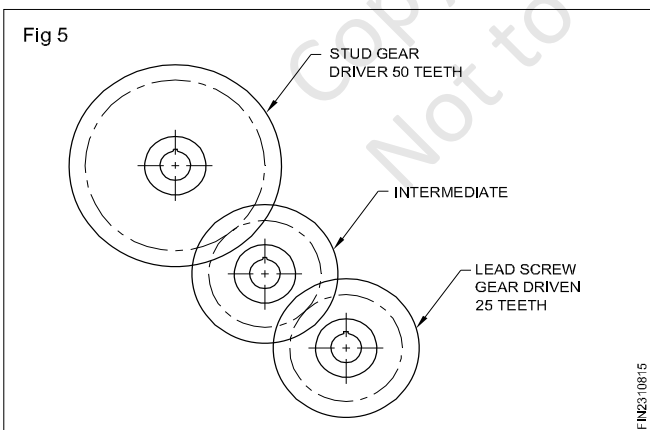

Let us compare the above three examples.

Examples :	Case 1	Case 2	Case 3
Pitch(Lead)of job	4	2	8
Pitch(Lead) of L.S	4	4	4
Driver	50	50	50
Driven	50	100	25

Stating the above in a formula,

$$\text{The gear ratio} = \frac{\text{Driver}}{\text{Driven}} = \frac{\text{Lead of work}}{\text{Lead of lead screw}}$$

Solved examples

- 1 Find the change gears required to cut a 3 mm pitch on a job in a lathe, having a lead screw of 6 mm pitch. (Fig 6)

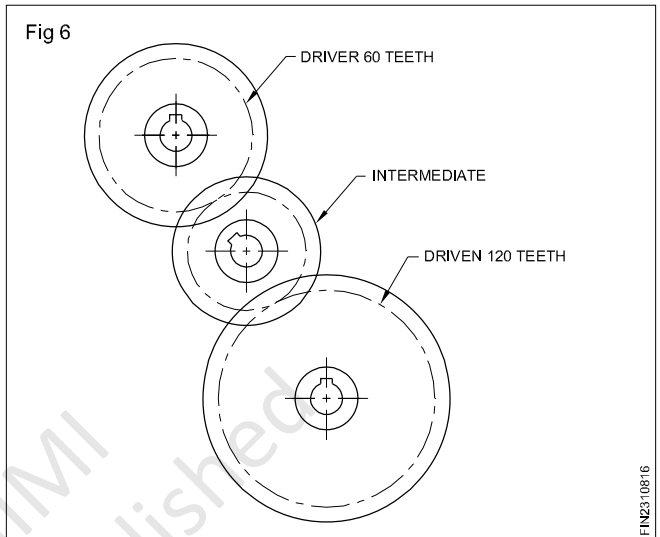

Ratio = Driver = Lead of work

$$\text{The gear ratio} = \frac{3}{6} = \frac{3 \times 20}{6 \times 20} = \frac{60}{120}$$

Driver = 60 teeth

Driven = 120 teeth

- 2 Find the change gears required to cut a 2.5 mm pitch in a lathe, having a lead screw of 5 mm pitch. (Fig 7)

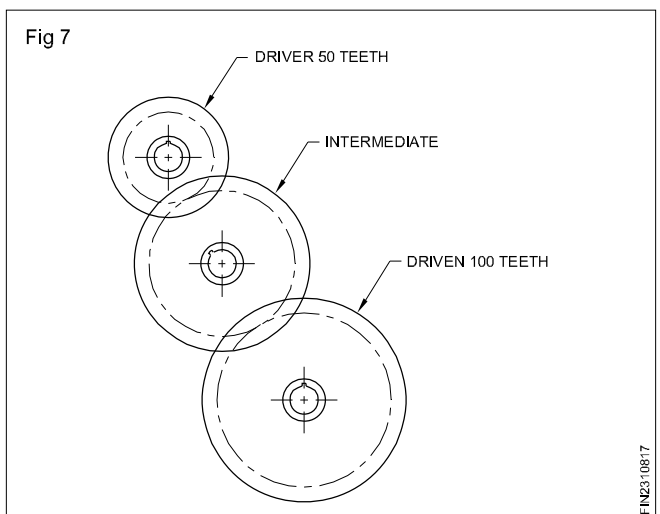

$$\text{Ratio} = \frac{\text{Driver}}{\text{Driven}} = \frac{\text{Lead of work}}{\text{Lead of lead Screw}}$$

$$= \frac{2.5}{5} = \frac{2.5 \times 20}{5 \times 20}$$

$$= \frac{50 \text{ (Driver)}}{100 \text{ (Driven)}}$$

- 3 Calculate the gears required to cut a 1.5 mm pitch in a lathe having a lead screw of 5 mm pitch. (Fig 8)

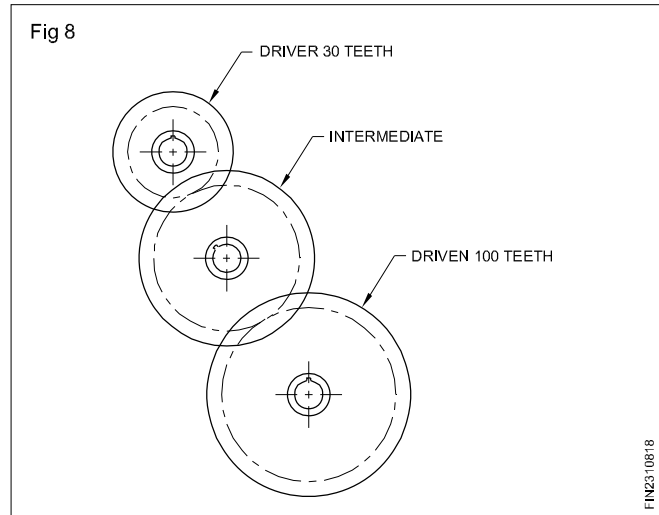

$$\text{Ratio} = \frac{\text{Driver}}{\text{Driven}} = \frac{\text{Lead of work}}{\text{Lead of lead Screw}}$$

$$= \frac{1.5}{5} = \frac{3}{10} = \frac{3 \times 10}{10 \times 10}$$

$$= \frac{30 \text{ (Driver)}}{100 \text{ (Driven)}}$$

Copyright @ NMI
Not to be Republished

Principle of chasing screw thread

Objectives: At the end of this lesson you shall be able to

- state the necessity of a thread chasing dial
- state the constructional details of a British thread chasing dial
- state the functional features of a British thread chasing dial.

Thread chasing dial

To catch the thread quickly and to save manual labour, use of a chasing dial is very common during thread cutting by a single point cutting tool. A thread chasing dial is an accessory.

Constructional details (Fig 1)

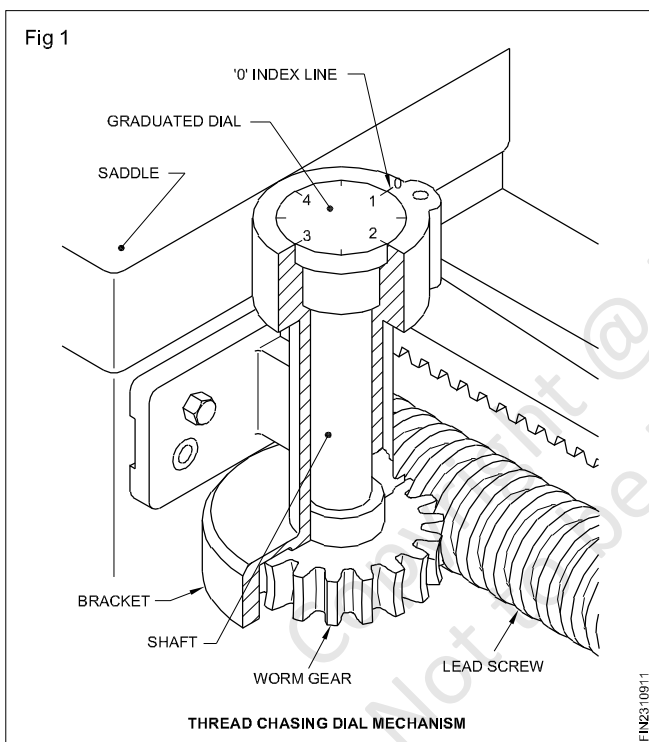

The figure shows constructional details of a British thread chasing dial. It consists of a vertical shaft with a worm wheel made out of brass or bronze, attached to the shaft at the bottom. On the top, it has a graduated dial. The shaft is carried on a bracket in bearing (bush) which is fixed to the carriage. The worm wheel can be brought into an engaged or disengaged position with the lead screw as needed. When the lead screw rotates it drives the worm wheel which causes the dial to rotate. The movement of the dial is with reference to the fixed mark ('O' index line).

The face of the dial is usually graduated into eight (8) divisions, having 4 numbered main divisions and 4 unnumbered subdivisions in between.

The number of teeth on the worm gear is the product of the number of threads per inch on the lead screw and the number of numbered divisions on the dial.

Each numbered division represents 1 inch travel of the carriage.

Let the worm wheel have 16 teeth, and the lead screw 4 TPI. The number of numbered graduations and unnumbered graduations are 4 each.

The half nut can be engaged 8 times for one revolution of the graduated dial. The movement of the carriage for one complete revolution of the dial is 4". (Fig 2) Since the dial is having totally 8 graduations marked, each graduation represents 1/2" travel of the carriage.

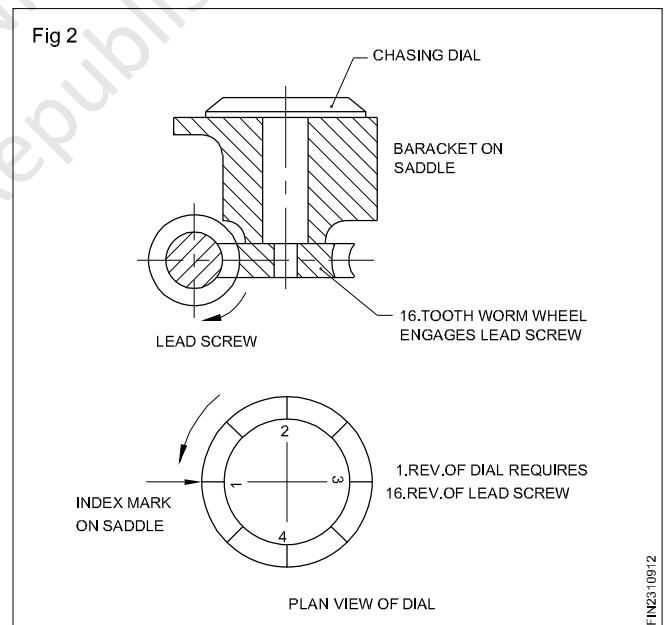

The chart given here shows the positions at which the half nut is to be engaged when cutting different threads per inch, when a British thread chasing dial with the above data is fitted to the lathe.

THREAD CHASING DIAL CHART

Threads per inch to be cut	Dial graduation at which the half nut can be engaged to catch the thread	Reading on the dial illustrated
Threads which are a multiple of the number of threads per inch of the lead screw.	Engage at any position the half nut meshes.	Use of dial unnecessary.

Example T.P.I. to be cut - 8

$$\frac{DR}{DN} = \frac{\text{T.P.I. on lead screw}}{\text{T.P.I. to be cut}} = \frac{4}{8} = \frac{1}{2}$$

$$\text{Predetermined travel} = 1 \times \frac{1''}{4} = \frac{1''}{4}$$

The predetermined travel of 1/4" is represented by the dial position in the exact middle between any numbered division and adjacent un-numbered division. The half nut engagement can be done at any position at which it can be engaged (ie. 16 positions).

Referring to the dial is not necessary.

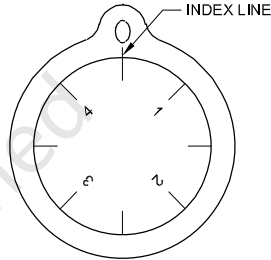
Even number of threads	Engage at any graduation on the dial.	1 1 1/2 2 2 1/2 3 3 1/2 4 4 1/2	
	8 positions		

Example T.P.I. to be cut - 6

$$\frac{DR}{DN} = \frac{\text{T.P.I. on lead screw}}{\text{T.P.I. to be cut}} = \frac{4}{6} = \frac{2}{3}$$

$$\text{Predetermined travel} = 2 \times \frac{1''}{4} = \frac{1''}{2}$$

The predetermined travel of 1/2" is represented by dial movement from any numbered division to the next adjacent unnumbered division. The half nut can be engaged when any numbered or unnumbered graduation coincides with the zero line (8 positions).

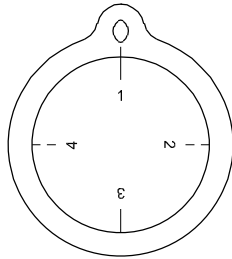
Odd number of threads	Engage at any main division.	1 2 3 4	
	4 positions		

Example T.P.I. to be cut - 5

$$\frac{DR}{DN} = \frac{\text{T.P.I. on lead screw}}{\text{T.P.I. to be cut}} = \frac{4}{5} = \frac{4}{5}$$

$$\text{Predetermined travel} = 4 \times \frac{1''}{4} = 1''$$

The predetermined travel of 1" is represented by the dial movement from any numbered division to the next numbered division or from any unnumbered division to the next unnumbered division. Therefore, if the first cut is taken when a numbered division of the dial coincides with zero, then the half nut engagement for successive cuts can be done when any numbered division coincides with the zero mark. If the first cut is taken when an unnumbered division coincides with the zero, then the half nut for successive cuts, is engaged when any unnumbered division coincides with the zero. (4 positions)

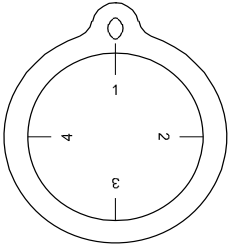
Half fractional number of threads	Engage at every other main division. 2 positions	1 & 3 or 2 & 4 
-----------------------------------	---	---

Example T.P.I. to be cut - 3 1/2

$$\frac{DR}{DN} = \frac{\text{T.P.I. on lead screw}}{\text{T.P.I. to be cut}} = \frac{4}{3 \frac{1}{2}} = \frac{8}{7}$$

Predetermined travel = $8 \times \frac{1''}{4} = 2''$

The half nut can be engaged only at opposite numbered or unnumbered graduations (2 positions).

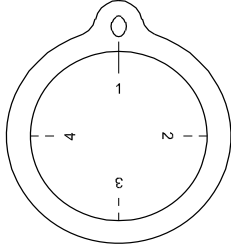
Quarter fractional number of threads	Engage at the same main division. 1 position	1 or 2 or 3 or 4 
--------------------------------------	---	---

Example T.P.I. to be cut - 2 3/4

$$\frac{DR}{DN} = \frac{\text{T.P.I. on lead screw}}{\text{T.P.I. to be cut}} = \frac{4}{2 \frac{3}{4}} = \frac{16}{11}$$

Predetermined travel = $16 \times \frac{1''}{4} = 4''$

The half nut can be engaged to catch the thread only when the same numbered or unnumbered graduated line, at which the first cut is taken, coincides with the zero line (1 position only).

Example T.P.I. to be cut - 1 3/8

$$\frac{DR}{DN} = \frac{\text{T.P.I. on lead screw}}{\text{T.P.I. to be cut}} = \frac{4}{1 \frac{3}{8}} = \frac{32}{11}$$

Predetermined travel = $16 \times \frac{1''}{4} = 4''$

The half nut engaged for the first cut should remain at the engaged position till thread cutting is completed and the machine is reversed as it takes a long time to cover the predetermined travel arrived at by calculation.

Example T.P.I. to be cut - 1 3/8

$$\frac{DR}{DN} = \frac{\text{T.P.I. on lead screw}}{\text{T.P.I. to be cut}} = \frac{4}{1 \frac{3}{8}} = \frac{32}{11}$$

Predetermined travel = $32 \times \frac{1''}{4} = 8''$

The half nut engaged for the first cut should remain at the engaged position till thread cutting is completed and the machine is reversed as it takes a long time to cover the predetermined travel arrived at by calculation.

Centre gauge

Objectives: At the end of this lesson you shall be able to

- define centre gauge
- write the uses of centre gauge.

Centre gauge: (Fig 1)

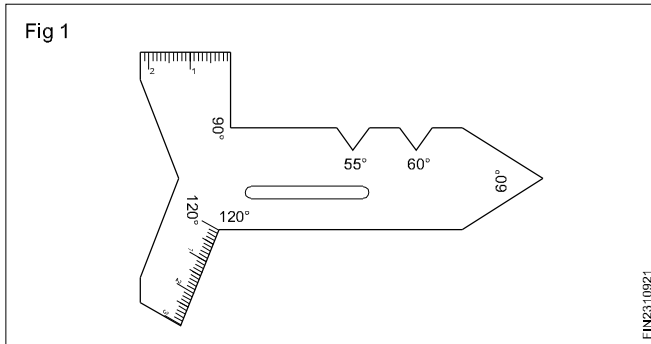

Centre gauges and fish tail gauges are gauges used in lathe work for checking the angles when grinding the profiles of single point screw cutting tool bits and centers. In

the image, the gauge on the left is called a fishtail gauge or centre gauge, and the one on the right is another style of center gauge.

These gauges are most commonly used when hand grinding threading tool bits on a bench grinder, although they may be used with tool and cutter grinders.

When the tool bit has been ground to the correct angle, they may then be used to set the tool perpendicular to the workpiece.

They can incorporate a range of sizes and types on the one gauge, the two most common being metric or UNS at 60°, and BSW at 55°. Gauges also exist for the acme thread form.

Tool setting - external thread

Objectives: At the end of this lesson you shall be able to

- tool setting to cut external thread by half angle method.

Check the diameter of the workpiece to be threaded by referring to the drawing.

To provide thread clearance, it is good practice to turn the diameter of the workpiece undersize depending upon the required.

Set the lathe spindle speed to about one fourth of the turning speed.

Set the gearbox according to the pitch of thread to be cut.

Swivel the compound slide to 90° from the horizontal position to bring it in line with the cross-slide.

Swivel to the right 1° less than the half included angle of the thread it is a right hand thread. (Fig 1)

The angle to which the compound rest is set affects the cutting action of the cutting tool by producing a shearing action on the trailing edge of the tool. This produces a smooth cut.

Set the tool in the tool post with a minimum overhand perpendicular to the axis and also set with a centre gauge. (Fig 2)

Mark out the length of the workpiece to be threaded.

Chamfer the end of the workpiece surface with the leading edge of the cutting tool to a depth, just greater than the minor diameter of the thread to be cut.

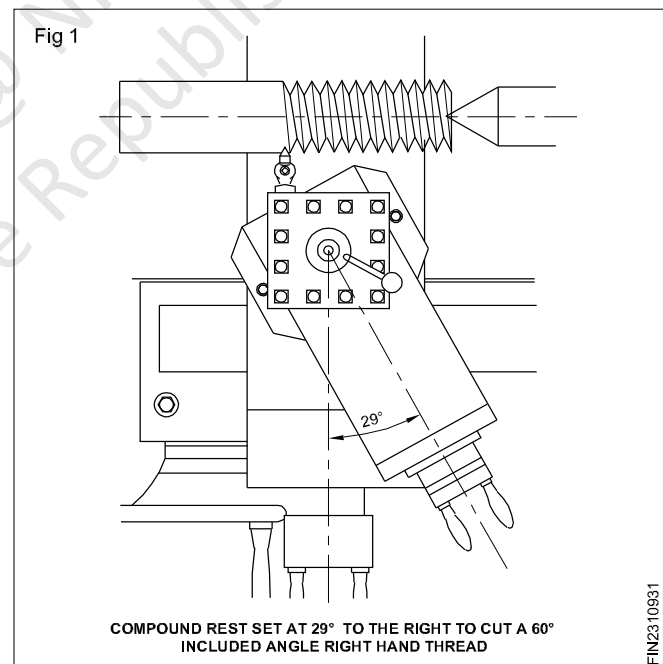

Advance the cutting tool to the work surface by operating the cross-slide hand wheel.

When the tip of the tool just touches the work surface, stop further advancement and set the cross-slide and compound slide graduated collars to zero.

Move the carriage to the right until the end of the tool clears the work.

Feed the tool in about 0.1 mm using the top slide hand wheel.

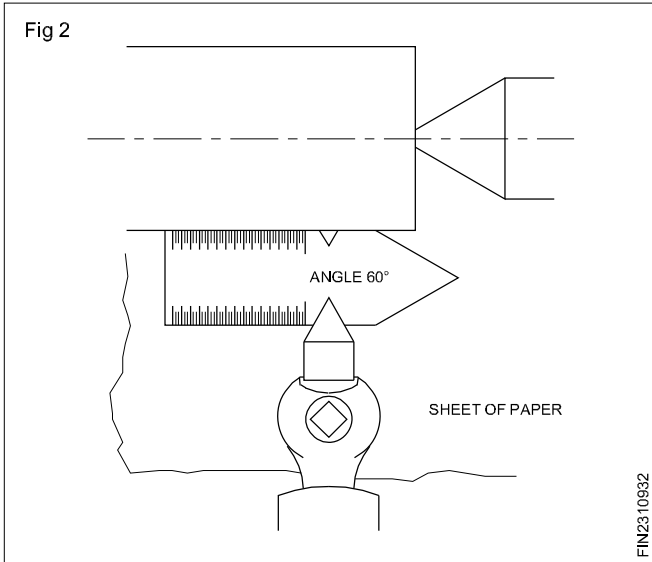

Engage the half nut referring to be chasing dial.

Take a trial cut along the workpiece to be threaded. (Fig 3)

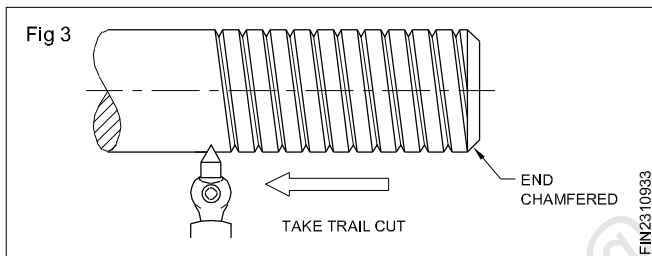

At the end of the trial cut, withdraw the tool immediately, winding it clear off the workpiece by operating the crossslide hand wheel and simultaneously reversing the machine. (Fig 4)

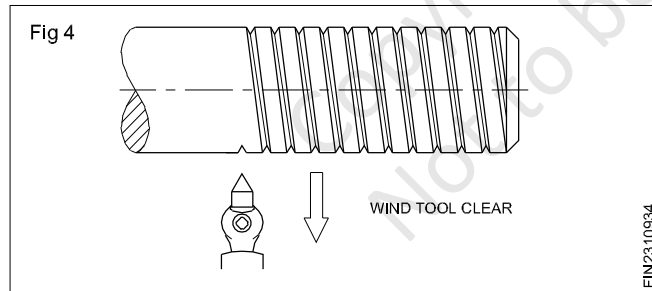

Allow the carriage to move to the right till it is cleared from the end of the work, and stop the machine. (Fig 5)

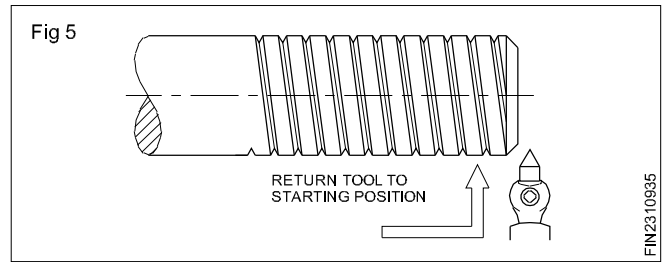

Check the thread formation with a pitch gauge.

Advance the tool by the cross-slide hand wheel till zero position.

Give depth of cut with the top slide handle.

Start the machine and allow the tool to cut the thread. (Fig 6)

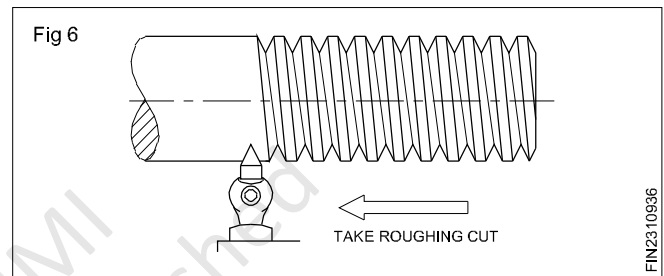

Use plenty of coolant during threading.

Repeat the steps till the required depth is reached. (Fig 7)

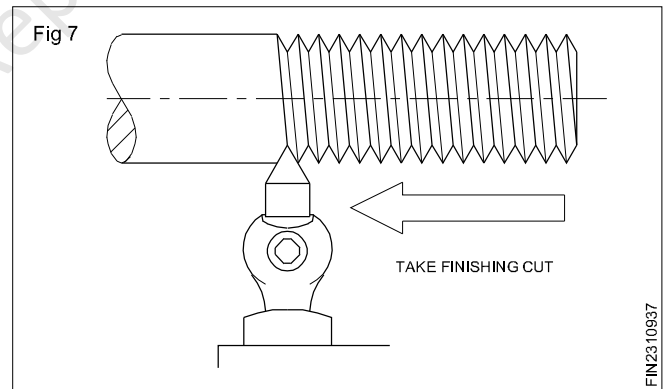

Note: At the end of each cut, the tool is withdrawn from the work by the cross-slide hand wheel and the carriage is brought to the starting point. The cross-slide hand wheel is brought to zero position and a depth of cut is given by the top slide.

Cutting an internal thread

Objectives: At the end of this lesson you shall be able to

- tool setting to cut an internal thread.

Mount the job on four jaw chick/three jaw chuck/ collect.

Drill and bore the job to the core diameter of the thread to required length/through hole.

For a blind hole, cut a recess at the end of the bore enough to permit the cutting tool to clear thread.

The recess must be larger than the major diameter of the thread. (Fig 1)

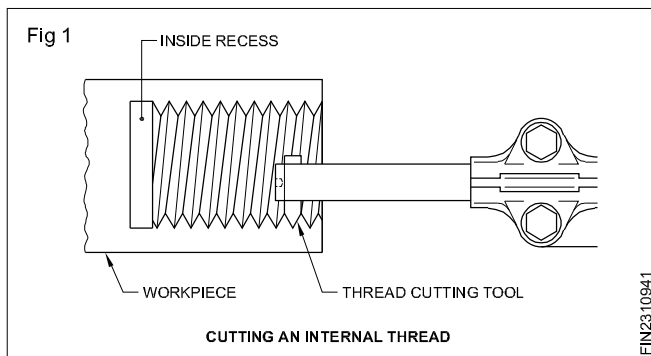

Chamfer the front end to $2 \times 45^\circ$.

Set the compound rest at 29° to cut 60° included angle as shown in Fig 2.

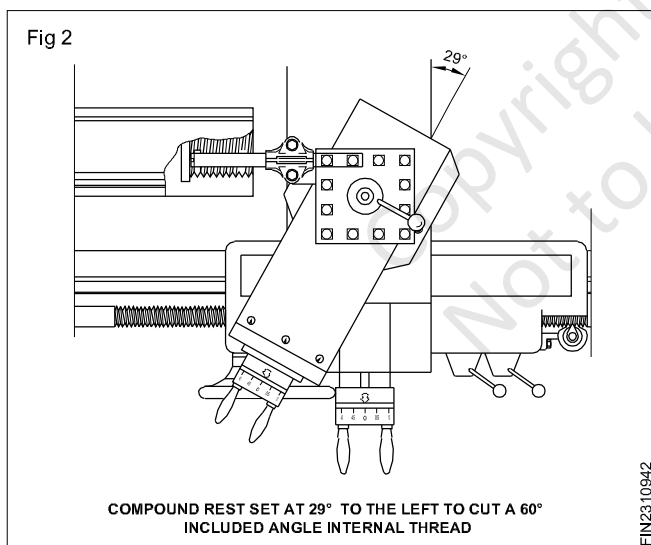

Set the gear box levers to the required pitch.

Fix the correctly ground threading tool in a boring bar.

Fix the boring bar parallel to the lathe centre line and set the point of the cutting tool to lie on the centre.

Align the cutting tool with a help of centre gauge as shown in Fig 3.

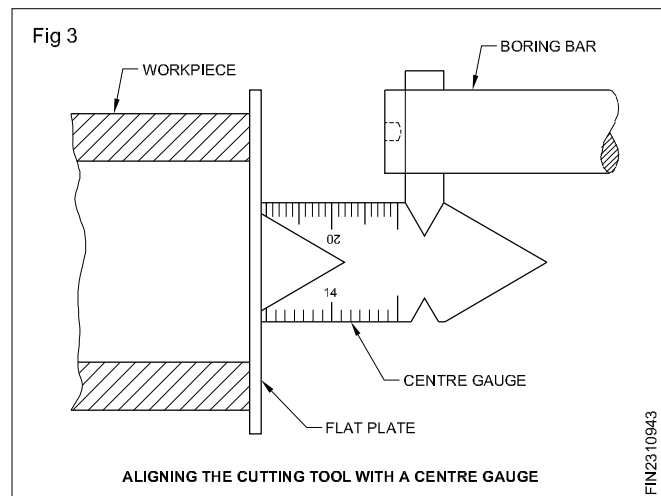

Mark the boring bar to indicate the required depth to entry into the bore.

Ensure that the boring bar does not foul anywhere on the job.

Reverse the cross slide until the tool point just touches the bore.

Set the cross-slide and compound slide graduated collars to zero.

Withdraw the cutting tool from the bore.

Set the spindle speed to $1/3$ of the calculated r.p.m.

Start the machine.

Adjust the depth of cut to 0.1 mm.

Engage the half nut.

At the end of the cut, simultaneously reverse the chuck and clear the tool just away from the thread.

Ensure that the tool should not touch the thread in both side of the bore.

When cutting tool comes out of the bore stop the machine.

Give the depth of cut and run the machine in forward direction. Similarly finish the thread until final depth is achieved.

Check the finished thread with a thread plug gauge or a threaded bolt.

Screw pitch gauge (Refer Related theory ex.no. 2.1.68-69)

Objectives: At the end of this lesson you shall be able to

- state the purpose of a screw pitch gauge
 - state the features of a screw pitch gauge.
-

For obtaining accurate results while using the screw pitch gauge, the full length of the blade should be placed on the threads. (Fig 1)

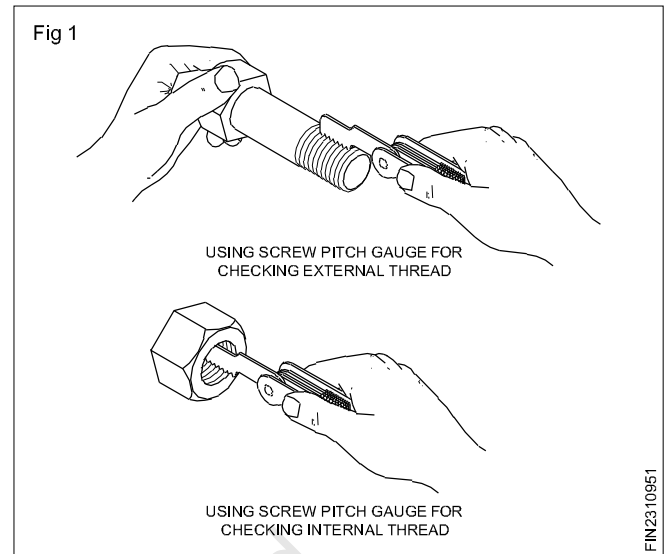

Total productive maintenance

Objectives: At the end of this lesson you shall be able to

- explain the concept of TPM
 - state advantages of TPM
 - explain the concept of OEE
 - describe the components of OEE and their effects.
-

Total Productive Maintenance(TPM) concepts

TPM aims to maximize overall equipment effectiveness. Establishes a complete system of productive maintenance for the machines/equipments entire lifespan is implemented by various departments. [Engineering, Operations, Maintenance, Quality and Administration]

TPM can be considered as the medical science of machines.

TPM involves every single employee, from top management to all the operators on the shop floor. TPM raises and implements productive maintenance based on autonomous small group activities.

TPM is a maintenance program which involves a newly defined concept for maintaining plants and equipments.

The goal of TPM is to an extent increase production while, at the same time, increasing employee morale and job satisfaction.

TPM brings maintenance into focus as a necessary and vitally important part of the business. It is no longer regarded as a non-profit activity.

Downtime for maintenance is scheduled as a part of the manufacturing day. In some cases as an integral part of the production process.

The goal of TPM is to stop the emergency and unscheduled maintenance.

Form different teams to reduce defects and self maintenance.

Advantages of TPM

- Avoids wastage in quickly changing economic environment.
- Produces goods without reducing product quality.
- Reduces maintenance cost.
- Produces a low batch quantity at the earliest possible time.
- Ensures the non defective goods to the customers.

- Reduce customers complaints.
- Reduce accidents.
- Follow pollution control measures.
- Favourable change in the attitude of the operator.

Overall equipment effectiveness (OEE)

Overall equipment effectiveness (OEE) is a concept utilized in a lean manufacturing implementation. OEE is described as one such performance measurement tool that measures different types of production loses and indicate areas of process development. The OEE concept normally measures the effectiveness of a machine center or process line, but can be utilized in non-manufacturing operation also.

The high level formula for the lean manufacturing OEE is

$$\text{OEE} = \text{Availability} \times \text{Productivity} \times \text{Quality}$$

Availability

The availability is part of the above equation measures the percentage of time the machine/equipment of operation was running compared to the available time. For example if the machine was available to run 20 hours but was only run for 15, then the availability is 75 percent 15/20. The five hours when the machine didn't run would be set up time, breakdown or other downtime. The 4 hours the company did not plan to run the machine is rarely used in the calculation.

Performance

The performance part of the equation measures the running speed of the operation compared to its maximum capability often called the rated speed. For example, if a machine produced 80 pieces per hour while running, but the capability of the machine is 100, then the performance is 80% (80/100). The concept can be used multiple ways depending on the capability number. For example, the machine might be capable of producing 100 pieces per hour with the perfect part, but only 85 on that particular order. When the capability of 100 is used for the calculation, the result is more a measure of facility OEE.

Quality

The third portion of the equation measures the number of good parts produced compared to the total number of parts made. For example if 100 parts are made and 95 of them are good, the quality is 95% (95/100).

Combining the above example into the OEE equation the OEE is

$$\text{OEE} = 75\% \times 80\% \times 95\% = 57\%$$

Autonomous Maintenance

Autonomous Maintenance put simply is the restoration and prevention of accelerated deterioration and has a major positive effect on OEE. It is a step by step improvement process, rather than production teams taking on maintenance tasks.

- Understanding the equipment functions and safety risks.

The seven steps of Autonomous Maintenance

1 Initial cleaning (Initial inspection & registration)	<ul style="list-style-type: none">- Detect problem of the lives and restore the original state.- Start managing the line autonomously (5s, Minor stops, quality) autonomously- Create & perform temporary "cleaning/lubrication produces"
2 Source of contamination & Hard-to-reach areas	<ul style="list-style-type: none">- Solve "sources of contamination" and hard to reach clear (Cleaning, Inspection lubrication)
3 Standard of cleaning & lubrication	<ul style="list-style-type: none">- Develop tentative standards for cleaning lubrication and inspection.
4 General Inspection	<ul style="list-style-type: none">- Provide training on their equipments, products and materials, inspection skills and other Am skills.
5 Autonomous Inspection	<ul style="list-style-type: none">- Develop a routine maintenance standard by operations.
6 Standadize autonomous maintenance operation	<ul style="list-style-type: none">- Standadize routine operation related to work place management such as quality inspection of products, life cycle of jigs, tools, set up operation and safety
7 Autonomous management	<ul style="list-style-type: none">- Autonomous team working.

Routine maintenance

Objectives: At the end of this lesson you shall be able to

- **state the need for routine maintenance**
- **describe the functions of routine maintenance**
- **state the advantages of routine maintenance.**

Routine Maintenance

- In order to get trouble free service from productive equipment.
- Following activities is necessary to carry out.
 - i Lubrication
 - ii Periodic inspection
 - iii Adjustments of various parts
 - iv Cleaning

All the above maintenance operations are carried out while the machine is running or during pre-planned shutdowns.

This type of maintenance may prevent breakdown of equipments.

Routine maintenance should not interfere with production schedules.

Planned preventive maintenance (PPM), more commonly referred to as simply planned maintenance (PM) or scheduled maintenance, is any variety of scheduled maintenance to an object or item of equipment. Specifically, planned maintenance is a scheduled service visit carried out by a competent and suitable agent, to ensure that an item of equipment is operating correctly and to therefore avoid any unscheduled breakdown and downtime.

Along with condition based maintenance planned maintenance comprises preventive maintenance, in which the

maintenance event is preplanned, and all future maintenance is preprogrammed. Planned maintenance is created for every item separately according to manufacturers recommendation or legislation. Plans can be date-based, based on equipment running hours, or on the distance travelled by the vehicle. A good example of planned maintenance program is car maintenance, where time and distance determine fluid change requirements. A good example of condition based maintenance is the oil pressure warning light that provides notification that you should stop the vehicle because engine lubrication has stopped and failure will occur.

Planned maintenance has some advantages over condition-based maintenance (CBM), such as:

- Easier planning of maintenance and ordering spares.
- Costs are distributed more evenly.
- No initial costs for instruments used for supervision of equipment.

Disadvantages are:

- Less reliable than equipment with fault reporting associated with CBM.
- More expensive due to more frequent parts change.
- Requires training investment and on going labour costs.

Parts that have scheduled maintenance at fixed intervals, usually due to wearout or a fixed shelf life, are sometimes known as time-change interval or TCI items.

Maintenance schedule

Objective: At the end of this lesson you shall be able to

- **describe the normal procedure followed in machine tool maintenance in shop floor.**

Any kind of action or activity there should be some procedure and sequence likewise maintenance also has some normal procedure to execute the maintenance activity without any confusion. If maintenance is not followed any procedure there will be time loss and the machine and equipment could not be ready in time. The procedure guides the maintenance people how to start, execute, where to inspect and how to complete the maintenance in time. The maintenance is carried out with the following procedure.

- Initial cleanup
- Identification of fault
- Dismantling
- Inspection
- Identification of cause for defect
- Inspection and replacement/ Repair of spares
- Reassembling

- Trial run
- Inspection with standards
- Maintaining records

Initial cleanup

Main machine, connected accessories, lubrication system, panels and adjacent parts are to be cleaned first.

Identification of fault

The fault of the machine is to be identified by visual inspection and getting information from the complaint and justified the same.

Dismantling

The fault area is dismantled with the referring to the manual and all the spares are kept separate in a tray and preserved safely.

Inspection

All the dismantled parts such as gear, bearing, shaft, key, etc. are cleaned and inspected for any damages. Any damages/breakage is recorded in the maintenance checklist.

Identification of cause for defect

The defect in spare parts thoroughly examined and analysed the causes for damage and the same has to be rectified.

Inspection and replacement/ repair of spares

The damaged or broken spares are procured from stores/ repaired and the same is inspected to the standards.

Reassembling

The next course of action is assembling the parts in reverse manner of dismantling order.

Trial run

After completion of assembling the machine is to run first manually and all the lubrication, electrical connection to be given. Finally the machine should run on is trial run for some time and observed for any unusual sound from the machine.

Inspection with standards

The machine is finally checked/inspected for geometry accuracy safety hazards etc., according to the manufacturer standard any other recommended standard as required by the nature of maintenance work carried.

Maintaining records

All the activities related to fault attended, spares changed, etc. to be recorded in the inspection report/maintenance record, machine history cards suitably for future reference.

Preventive maintenance

Objectives: At the end of this lesson you shall be able to

- state the need for preventive maintenance
 - describe the functions of the P M department
 - state the advantages of P M
 - state the advantages of maintenance records and periodic inspection of machines.
-

Need for Preventive maintenance

The machine tools are of high precision, and are sensitive and expensive.

They must be handled and maintained carefully in order to give good and long service.

The basic function of the maintenance department is the upkeep of the machines and equipments in good operating condition.

Earlier the maintenance of the equipment used to receive attention only when the equipment suffered some set-back or breakdown as a result of some minor/major fault. Such breakdowns not only brought a serious production hold-up but also used to upset the production flow of the industry where the other equipment also had to stand idle. This resulted in a more cautious approach to the maintenance of the equipment and this brought up the more scientific way of tackling the maintenance problem, through preventive maintenance. (P M)

Preventive maintenance

Preventive maintenance consists of a few engineering activities which help to maintain the machine tools in good working order.

The basic activities of preventive maintenance are the:

- Periodic inspection of machines and equipments to uncover conditions leading to production breakdowns or harmful depreciation
- Upkeep of machines and equipments to avoid such conditions or to adjust, repair or replace them while they are still in the initial stages.

Advantages of preventive maintenance system

- Less down time in production.
- Improves quantity and quality of product.
- Standby equipment is not needed which saves capital investment.
- Lower unit cost of manufacture.
- Reduces major and repetitive repairs of machines.
- P.M. helps in prolonging the life of the machines and reduction in un-expected breakdowns.

Functions of preventive maintenance department

- Periodic inspection of machines and equipments as per the 'Check- lists'. (Annexure I)
- Lubrication of machines and equipments as per the manufacturer's instruction manuals.
- Servicing and overhauling of machine and equipment as per the P M schedule.
- Keeping basic records of each machine and equipment. (Annexure II)
- Analysis of inspection reports and systematic review of reports of machines and equipments.

Periodic inspection of machines and equipments as per the check-list

The check-list items for the inspector about all the points to be checked on individual machines. While preparing the check-list of the machine, make sure that no machine part or item that is omitted needs attention. The inspection of machine tools like lathe and drilling machine includes the following.

- Driving system and feeding system
- Lubricating and coolant system
- Slides and wedges and gibs
- Belts, bearings, clutch, brake and operating controls
- Guideways, lead screws and their mating parts

After inspection of each machine, the inspector has to make out the list of parts which need repairs or spares for replacement.

Frequency of inspection

The frequency of inspection depends on the age, kind of machine and its operating conditions. Frequent inspection of machines and equipment may be expensive and frequency with long intervals may result in more breakdowns. A good balance is needed to bring optimum savings.

Lubrication of machines and equipments

The length of time a machine will retain its accuracy and give satisfactory service depends on the lubrication and care it receives. It is essential that lubrication of machines should be carried out systematically at regular intervals as recommended in the service manual supplied by the machine manufacturer.

The manufacturer’s manual contains all the necessary details like grade of oil, grease, oiling and greasing points and also indicates the time intervals of lubrication.

Maintenance records (Annexure III)

Keep a detailed record of faults, failures, repairs and replacements done for machines. It is useful to analyse

Keep a detailed record of faults, failures, repairs and replacements done for machines. It is useful to analyse the cause of a fault and rectification.

Maintenance records analysis

Systematic review and regular analysis of the equipment records will help to:

- Re-design the weak part which gives repetitive trouble
- Substitute with better material for high cost items
- Minimise frequent breakdowns
- Reduce the cost of production.

Preventive Maintenance Programme

Name of the Machine :
 Machine Number :
 Model No. & Make :

Location of the machine :

Annexure I

CHECK-LIST FOR MACHINE INSPECTION

Inspect the following items and tick in the appropriate column and list the remedial measures for the defective items.

Items to be checked	Good working/satisfactory	Defective	Remedial measures
Level of the machine			
Belt and its tension			
Bearing sound			
Driving clutch and brake			
Exposed gears			
Working in all the speeds			
Working in all feeds			
Lubrication system			
Coolant system			
Carriage & its travel			
Cross-slide & its movement			
Compound slide & its travel			
Tailstock’s parrallel movement			
Electrical controls			
Safety gaurds			

Inspected by

Signature

Name :

Date :

Signature of in-charge

History sheet of machinery & equipment

Description of equipment:	
Manufacturers' address:	
Supplier's address:	
Order No. and date:	
Date on which received:	
Date on which installed and placed:	
Date of commissioning:	
Size: Length X Width X Height	
Weight:	
Cost:	
Motor particulars:	Watts: r.p.m: Phase: Volts
Bearings/Spares record:	
Belt specification:	
Lubrication details:	
Major repairs and overhauls carried out with dates.	

MAINTENANCE RECORDS

Sl.No	Name of the machine	Nature of fault rectified	Date	Signature of in-charge

Copyright @ NIMI
Not to be Republished

Difference between breakdown maintenance and preventive maintenance

Sl.No.	Breakdown Maintenance	Preventive Maintenance
1	Maintenance is undertaken only after breakdown	Maintenance is undertaken only before breakdown
2	No attempt is made to prevent breakdown	Maintenance is made to prevent breakdown
3	This is unpredictable activity	Predictable activity
4	Maintenance cost less	Cost of maintenance is high
5	Not suitable for equipments like cranes, hoists, pressure vessels	Can be applied to all types of equipments
6	Results in production loss and more "Down time"	Such disadvantages are eliminated

Reactive Maintenance

The oldest maintenance approach is reactive. Equipment is not repaired or replaced until it breaks. In this maintenance equipment fails with little or no warning so this could be down until replacement parts arrive, resulting in income loss. In this maintenance cost and down time increased and also create safety issues. Reactive maintenance can be suitable in some situation such as for non critical and low cost equipment with little or no risk of capital loss or production loss.

Importance of breakdown maintenance and preventive maintenance in productivity

The importance of an effective maintenance program cannot be overlooked because it plays such an important role in the effectiveness of lean manufacturing. As in personal health care insurance, maintenance may be considered the health care of our manufacturing operation, business or service operation. The cost of routine maintenance is very small when its compared to the cost of a major breakdown at which time there is no production.

Purpose of maintenance

The importance use of routine maintenance is to ensure that all equipment required for production is operating at 100% efficiency at all times. Through short daily inspections, cleaning, lubricating and making small adjustment small problems can be detected and corrected before they become major problem that can shutdown a production line. A good maintenance program requires company wide participation and support by everyone ranging from the top executive to the shop floor personel.

Inspection, types of inspection and gadgets for inspection

Objectives: At the end of this lesson you shall be able to

- **retrieval of data from machine manual**
 - **state the need of inspection**
 - **state the function of inspection**
 - **list out the type of inspection**
 - **discuss the each type of inspection**
 - **list out the gadgets used for inspection.**
-

Retrieval of data from machine manual

Manual is one of the integral and necessary literary part that the operator has to know before handling and operating the machine. It will be provided by true manufacturer along with the supply of the machine.

Manual furnish all information about the machine like size of the machine, foundation and erection method, safety procedure to be followed, operating procedure and periodical maintenance required.

The machine manual will also provide about the required power supply, safety precaution grade of lubrication oil to be used etc., availability of suitable spare parts and details of dealer/supplier has to be provided in the manual otherwise use of any other parts will not suit and the machine will get damaged.

We have to refer and follow manual if any problem/defects arises during operation of the machine.

The manual will also provide the brand and type of tools that can be used, time period/life of the tools to be replaced based on the usage and periodical inspection to be carried out.

In general manual to provide information right from starting of the machine, operating method of machine and stopping the machine, in case of emergency to stop the machine.

Inspection

Inspection is necessary for any machine/equipment where remarkable risk to health and safety may arise from wrong installation, re-installation or any other circumstances. The purpose of inspection is to find whether machine can be operated, adjusted and maintained safely. The need for inspection and inspection intervals to be determined through risk assessment.

The summary of inspection should be recorded and same should be kept atleast until the next inspection of that machine. Machine/equipment that required inspection should not be used unless the machine has been inspected.

If the machine/equipment obtained from any other source (eg. hired). One should be ensure that physical evidence of last inspection is accompanied with the machine, such as inspection report, some form of tagging, labelling system or colour coding.

Function of Inspection in maintenance

- 1 Periodic inspection of machines and equipments as per checklist (Annexure 1)
- 2 Keeping basic records of each machine & equipments.
- 3 Preparation of list which need for repairs (or) spare for replacements.
- 4 Analysis of inspection report and systematic review of reports of machines/equipments.
- 5 Assigning of frequency of inspection.

The following Annexure 1,2 and 3 are the formats used in maintenance inspection.

Annexure I

INSPECTION CHECK-LIST			
Name of the machine :		Location of the machine :	
Machine No :			
Model No :			
Inspect the following items and tick in the appropriate column and list the measures for the defective items.			
Item to be checked	Good working/Satisfactory/Status	Defective	Remedial measures
Availability of machine manual			
Safety guards			
Installation			
Level of the machine			
Belt and its tension			
Bearing sound			
Driving clutch and brake			
Exposed gears			
Working in all the speeds			
Working in all the feeds			
Lubrication system			
Coolant system			
Sliding part and its travel			
Safety and limit switches			
Electrical controls			
Proper lighting			
Emergency stop			
Alarm speciality			
Condition of work holding devices			
Condition of tool holding devices			
Condition of accessories and attachments			
Chip collection and disposal			

Conclusion of inspection

Recommendations

Inspected by

Signature

Name :

Date :

Signature of incharge

Annexure II

EQUIPMENT RECORD

History sheet of machinery & Equipment

Description of equipment	
Manufacturer's address	
Supplier's address	
Order No. and date	
Date on which received	
Date on which installed and placed	
Date of commissioning	
Size: Length x Width x Height	
Weight	
Cost	
Motor particulars	Watts/H.P./ r.p.m: Phase: Volts:
Bearings/ spares/ record	
Belt specification	
Lubrication details	
Major repairs and overhauls carried out with dates	

Lubrication survey

Objectives: At the end of this lesson you shall be able to

- state the benefit of lubrication survey
- prepare the cost estimation.

How does a Lubrication survey work?

Lubrication survey of all equipment that requires lubrication.

- By points of lubrication
- Recommended LE products
- Application methods
- Drain or lube intervals
- Special remarks

The materail is compiled and a report is returned with the recommended lubricants for all of your equipment included.

What are the benefits of a Lubrication survey?

- A key part of a good preventive maintenance program.
- Product consolidation
 - Reduces inventory requirements
 - Minimizes product misapplication
- Assists maintenance personnel in seeing that all lubrication points are lubricated as scheduled.
- Reduces downtime and repair parts. Minimizes time spent with OEM manuals researching proper lubricants.
- Easily updated by your LE Representative to keep the survey effective.
- Increases equipment life.

Increase your profitability

Preventing equipment downtime is directly reflected in increased productivity. A refocus from the repair maintenane philosophy to the preventive approach is needed.

Hints for lubricating machines

- Identify the oiling and greasing points
- Select the right lubricants and lubricating devices
- Apply the lubricants

The manufacturer’s manual contains all the necessary details for lubrication of parts in machine tools. Lubricants are to be applied daily, weekly, monthly or at regular intervals at different points or parts as stipulated in the manufacturer’s manual.

These places are indicated in the maintenance manuals with symbols as shown in Fig 1.

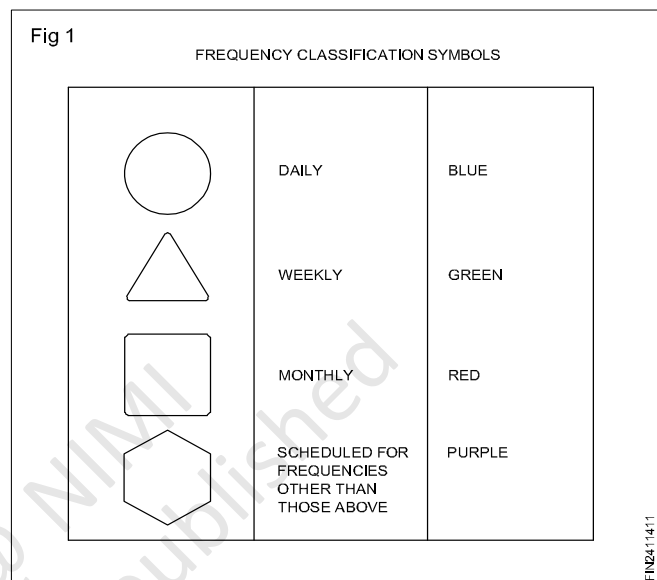

The best guarantee for good maintenance is to follow the manufacturer’s directives for the use of lubricants and greases. Refer to the Indian Oil Corporation chart for guidance.

The lubricant containers should be clearly labelled. The label must indicate the type of oil or grease and the code number and other details. Oil containers must be kept in the horizontal position while the grease container should be in the vertical position.

Cost Estimating Methods

Engineering Estimate with this technique, the system being costed is broken down into lower level components (such as parts or assemblies), each of which is costed separately for direct labour, direct material and other costs. Engineering estimates for direct labour hours may be based on analyses of engineering drawings and contractor or industry wide standards. Engineering estimates for direct material may be based on discrete raw material and purchase part requirements. The remaining elements of cost (such as quality control of various overhead changes) may be factored from the direct labour and materials costs. The various discrete cost estimates are aggregated by simple algebraic equations (hence the common name ‘bottoms-up estimate). The use of engineering estimates requires extensive knowledge of a system’s (and its components) characteristics and lots of detailed data.

Simple estimation of material

Objectives: At the end of this lesson you shall be able to

- state the purpose of estimation
 - explain the details of formats for estimation sheet
-

Estimation is the method of calculating the various quantities and the expenditure to be incurred on a particular job or process.

In case the funds available are less than the estimated cost the work is done in part or by reducing it or specifications are altered,

The following essential details are required for preparing an estimate.

Drawings like plan, elevation and sections of important parts.

Detailed specifications about workmanship & properties of materials, etc.

Standard schedule of rates of the current year.

Estimating is the process of preparing an approximation of quantities which is a value used as input data and it is derived from the best information available.

An estimate that turns out to be incorrect will be an overestimate if the estimate exceeded the actual result, and an underestimate if the estimate fell short of the actual result.

A cost estimate contains approximate cost of a product process or operation. The cost estimate has a single total value and it is inclusive of identifiable component values.

Hand book and reference table

A hand book is a type of reference work, or other collection of instruction. That is intended to provide ready reference. The term originally applied to a small portable book containing information useful for its owner, but the oxford english dictionary defines as "any book giving information such as facts on a particular subject, guidance in some art or occupation, instruction for operating a machine etc. A handbook is sometimes referred to as a pocket reference.

Hand book may deal with any topic, and are generally having compact information in a particular field (or) technique. They are designed to be easily consulted and provides quick answer in a certain area.

Example of engineering hand book include parry's theoretical engineers hand book, mark standard hand book for machine engineer and the CRC hand book of chemistry and physics.

Reference table

A reference table may mean a set of references that are author may have cited (or) gained inspiration from whilst writing an article, similar to a bibliography.

It can also mean an information table that is used as a quick and easy reference for things that are difficult to remember such as comparing imperial with metric measurements. This kind of data is known as reference data.

ESTIMATION SHEET

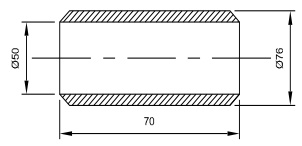
Part Name:	Part No.: 1	Insert Part Drawing 
Assembly:	Material: Fe310.0	
Assembly No.:	Stock size: \varnothing 80 ISR-70L	

Operation No.	Operation description	Lathe	Estimated time	Rate / per hr.	Tools
01	Setting and aligning job on lathe	-	10 min	Rs.100.00	
02	Set speed and feed	-	2 min	-	
03	Align cutting tool in position	-	2 min	-	
04	Turn the job	-	50 min	-	
05	Chamfer 45° angle corner	-	8 min	-	vernier bevel protractor
06	Reverse the job on Lathe	-	10 min	-	
07	Turn the job	-	20 min	-	
08	Chamfer 45° on other side	-	20 min	-	
09	Centre drilling	-	10 min	-	
10	Mount drill chuck and drill using tail stock	Drilling	03 min	-	
11	Set drill rpm	Drilling	02 min	-	
12	Drill holes	Drilling	20 min	-	
13	Set the boring tool	Drilling	15 min	-	
14	Bore to the required diameter		08 min	-	
15	Check the bore dia		10 min	-	Inside micrometer or bore dial gauge
16	Deburr the job and clean the machine	-	10 min	-	
17	Total hours		200 min		
18	Total estimation			Rs. 333.00	

Causes for assembly failures and remedies

Objectives: At the end of this lesson you shall be able to

- **state the poor assembly**
 - **list out poor service conditions**
 - **state the cost of operation.**
-

Poor assembling

Error in assembly can result due to various reasons such as ambiguous, insufficient or inappropriate assembly procedure, misalignment, poor workmanship. Sometimes, failures are also caused by the inadvertent error performed by the workers during the assembly. For example, failure of nut and stud assembly (used for holding the car wheel) by fatigue can occur owing to lack of information regarding sequence of tightening the nuts and torque to be used for tightening purpose; under such conditions any sort of loosening of nut which is subjected to external load will lead to fatigue failure.

Poor service conditions

Failure of an engineering component can occur due to abnormal service condition experienced by them for which they are not designed. These abnormal service conditions may appear in the form of exposure of component to excessively high rate of loading, unfavourable oxidative, corrosive, erosive environment at high or low temperature conditions for which it has not been designed. The contribution of any abnormality in Service conditions on the failure can only be established after thorough investigation regarding compatibility of the design manufacturing (such as heat treatment) and material of the failed components with condition experienced by them during the service.

Weight of raw material

Calculate theoretically weight of material, calculate volume of material and multiply with density of material. It gives you exact weight of raw material required.

While calculating weight do not consider final dimension always consider plus size for machining and other operation.

Cost of operation

Decide each operation to be performed on flanges like Drilling, machining and boring. While selecting the process do take care of sequence of operation as it matters a lot on costing.

You need to allot time required for particular operation considering all factors of machine. On their basis of price of machine, depreciation and cost of electricity consumed you need to finalise cost of machine running per hour.

Now multiply time required for particular operation and machine running cost/hour

Tools Cost

- **Cost of Labour:** For each piece calculate total working time consumed and calculate total cost need to pay to labour.
- **Accidental/Risk/Rejection cost:** As manufacturing of flange is a manual process, there may be chances of rejection of material, so this cost should be considered.

The simple method is add 1 piece's rate if manufacturing 100 qty in bulk

- **Packaging and handling cost:** Generally 2% of basic cost
- **Profit:** Approx 5 to 15% to basic cost
- **Admin and depreciation cost**

Assembly techniques

Objectives: At the end of this lesson you shall be able to

- name the common techniques used for assembling components
- distinguish between the application of dowelling, pinning, staking, brazing and use of adhesives for assembling components.

In machine shop assembly various methods are used for securing components together. A few of the common methods are:

- Dowelling
- Pinning
- Staking
- Brazing/Hard soldering
- Using of adhesives

Dowelling (Fig 1)

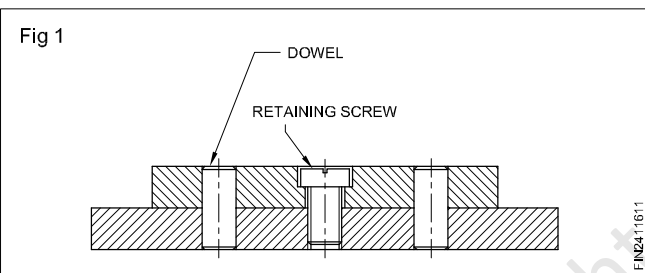

This is used for accurate positioning of two or more parts. This allows the parts to be separated and relocated in position. Different types of dowels are used depending on the type of assembly.

The components dowelled are always fixed with retaining screws in the assembly.

Pinning

This is also a method of locating and securing components together. Pins are of different types.

Parallel pins (Fig 2)

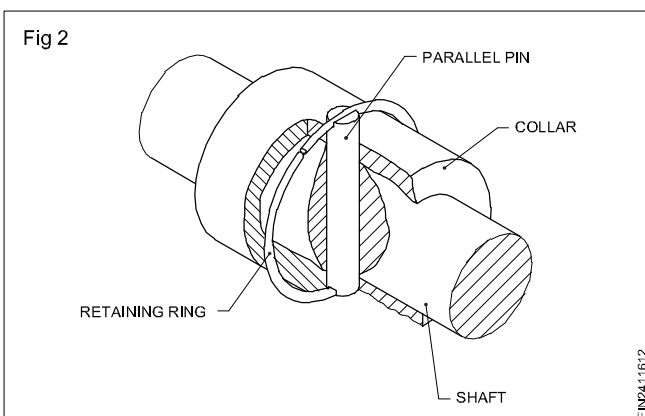

These are fitted like dowels in reamed holes and held in position by a retaining ring.

Cotter pins (Fig 3)

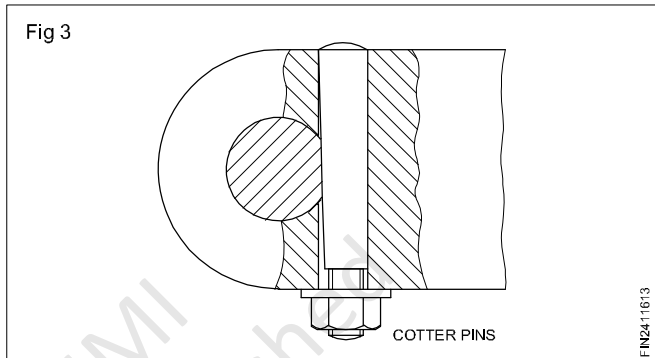

Taper pins (Fig 4)

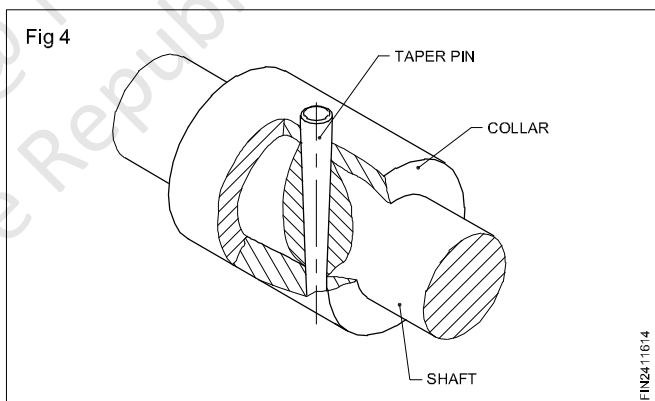

Taper pins will position parts accurately. The component can be dismantled easily and assembled without any change in location.

The holes for fitting taper pins are finished using taper pin reamers.

Spring pins (Fig 5)

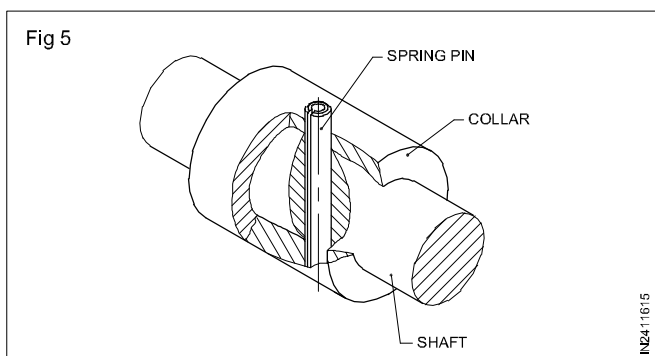

This eliminates the need for drilling and reaming of the assembly together. The spring pin adjusts itself in case of slight misalignment.

Peening (Fig 6)

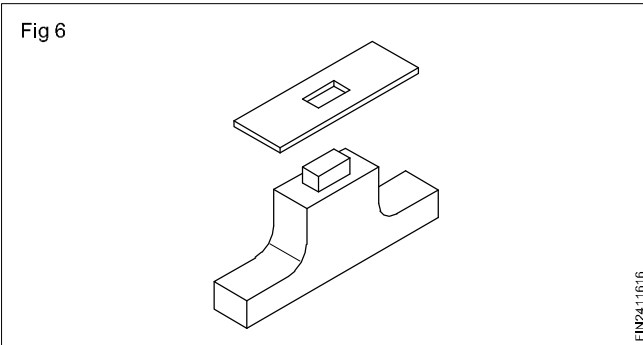

When parts are to be assembled together this is one method of assembly. Basically this is similar to riveting.

Staking (Figs 7a, b & c)

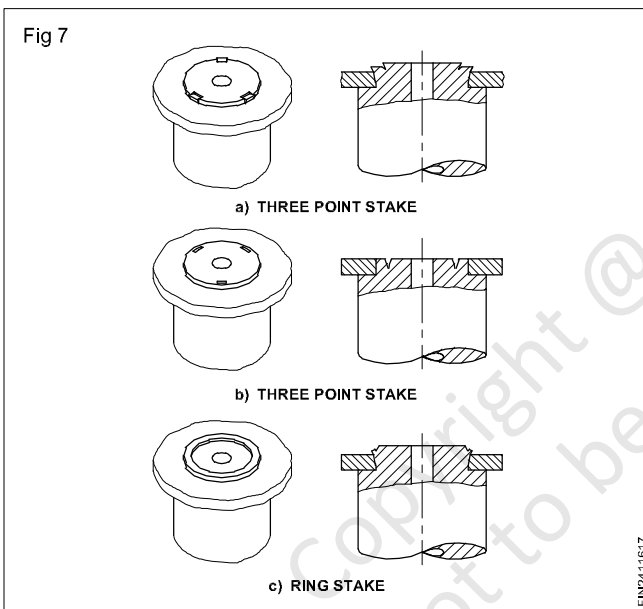

This is a method of retaining parts in an assembly in which a portion or all of a component is forced to flow on the other component. This increases the efficiency of the fit.

Brazing and hard soldering (Fig 8a & b)

This is a process of joining metals by using layer of non-ferrous metal between the surface to be joined.

The alloy used for brazing is known as spelter (combination of copper and zinc)

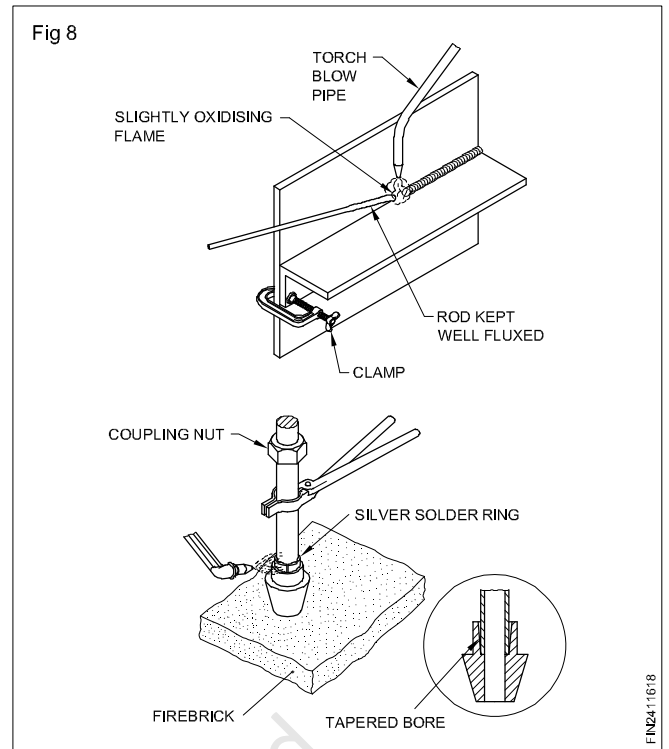

Adhesives (Fig 9)

The adhesives commonly used are epoxy adhesives. This adhesive gives a strong bond between materials to be assembled. This is not affected by moderate moisture or heat. It is usually supplied in two containers/tubes. One is resin and the other is the hardener.

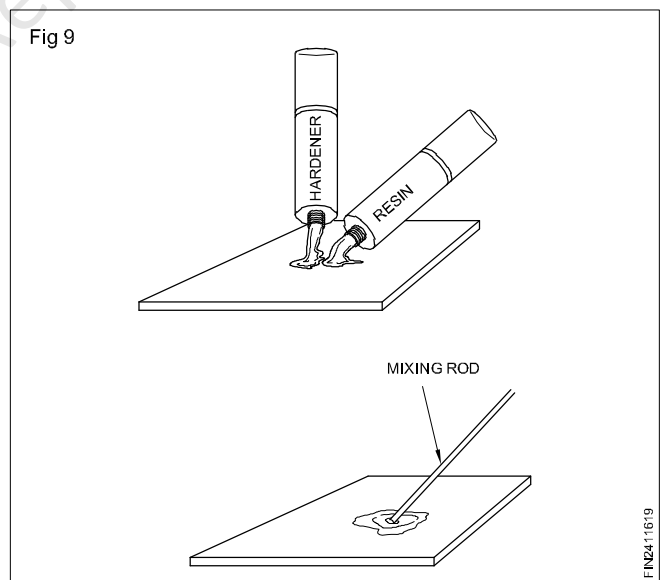

Threaded jointer

Objectives: At the end of this lesson you shall be able to

- state the situations in which bolts and nuts are used
- state the advantages of using bolts and nuts
- identify the different types of bolts
- state the applications of the different types of bolts
- state the situations in which studs are used
- state the reason for having different pitches of threads on stud ends.

Bolts and nuts (Fig 1)

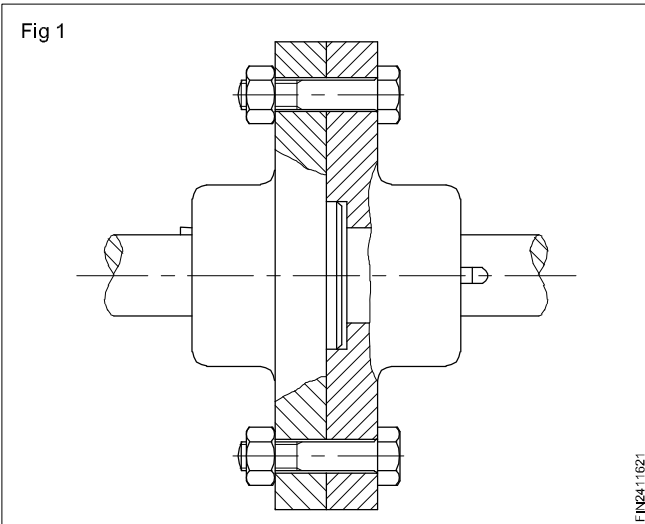

These are generally used to clamp two parts together.

When bolts and nuts are used, if the thread is stripped, a new bolt and nut can be used. But in the case of a screw directly fitted in the component, when threads are damaged, the component may need extensive repair or replacement.

Depending on the type of application, different types of bolts are used.

Bolts with clearance hole (Fig 2)

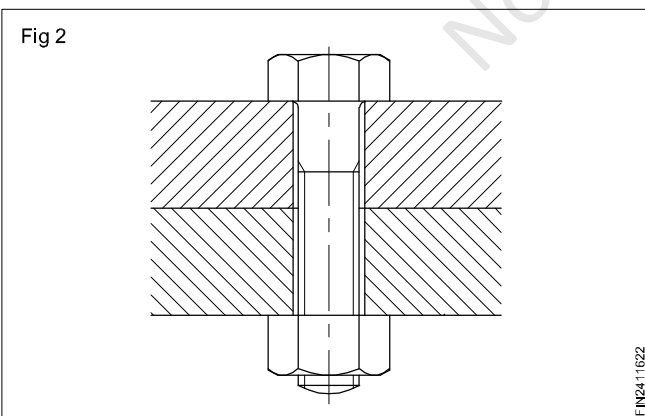

This is the most common type of fastening arrangement using bolts. The size of the hole is slightly larger than the bolt (clearance hole).

Slight misalignment in the matching hole will not affect the assembly.

Body fit bolt (Fig 3)

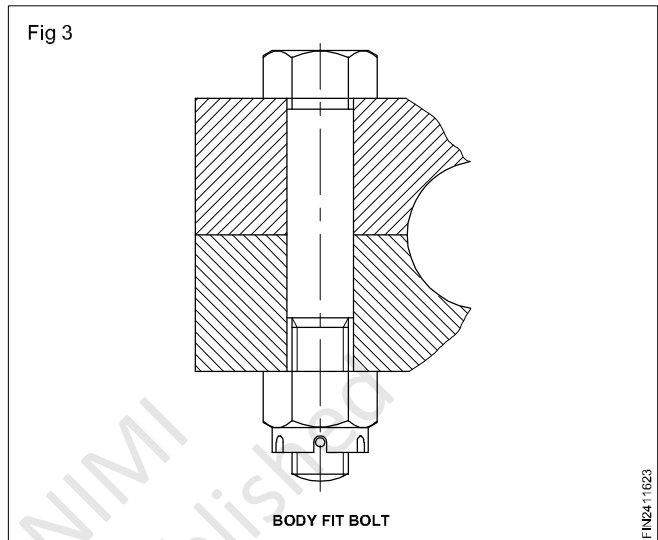

This type of bolt assembly is used when the relative movement between the workpieces has to be prevented.

The diameter of the threaded portion is slightly smaller than the shank diameter of the bolt.

The bolt shank and the hole are accurately machined for achieving perfect mating.

Anti-fatigue bolt (Fig 4)

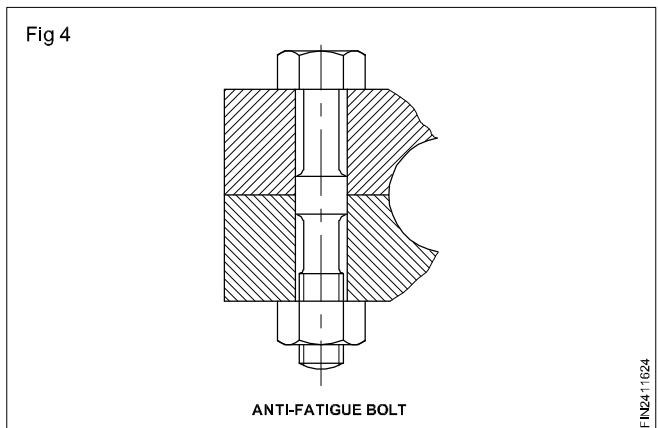

This type of bolt is used when the assembly is subjected to alternating load conditions continuously. Connecting rod big ends in engine assembly are examples of this application.

The shank diameter is in contact with the hole in a few places and other portions are relieved to give clearances.

Studs (Fig 5)

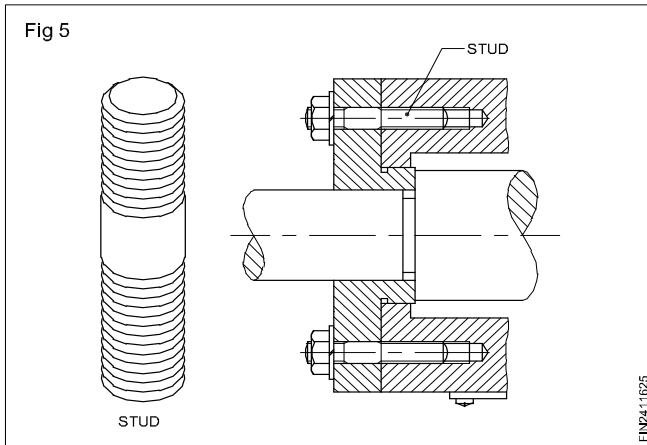

Studs are used in assemblies which are to be separated frequently.

When excessively tightened, the variation in the thread pitch allows the fine thread or nut end to strip. This prevents damage to the casting.

Designation of bolts as per B.I.S. specifications

Hexagon head bolts shall be designated by name, thread size, nominal length, property class and number of the Indian Standard.

Cylindrical and taper pins

Objectives: At the end of this lesson you shall be able to

- state the uses of cylindrical and taper pins
- specify cylindrical pins
- state the features and uses of different types of cylindrical pins
- state the advantages of of taper pins
- state the features and uses of the different types of taper pins
- designate standard taper pins
- distinguish the features and uses of the different types of taper pins
- state the uses of the different types of grooved pins
- state the features and uses of spring pins.

Cylindrical and taper pins

- Locating hole position for assemblies whenever they are dismantled and assembled (Examples - jigs and fixtures, cover plates, machine tool assembly etc.) (Figs 1a and 1b)
- Assembling components. (Examples - wheels, gears, levers, cranks etc. to shafts) (Figs 2a and 2b)

Example

A hexagon head bolt of size M10, nominal length 60 mm and property class 4.8 shall be designated as:

Hexagon head bolt M10 x 60 - 4.8 - IS:1363 (Part 1).

Explanation about property class

The part of the specification 4.8 indicates the property class (mechanical properties). In this case it is made of steel with minimum tensile strength = 40 kgf/mm² and having a ratio of minimum yield stress to minimum tensile strength = 0.8.

Note: Indian standard bolts and screws are made of three product grades - A, B, & C and 'A' being precision and the others of lesser grades of accuracy and finish. While there are many parameters given in the B.I.S specification, the designation need not cover all the aspects and it acutally depends on the functional requirement of the bolt or other threaded fasteners.

(For more details on the designation system, refer to IS:1367, Part XVI 1979.)

Fig 1

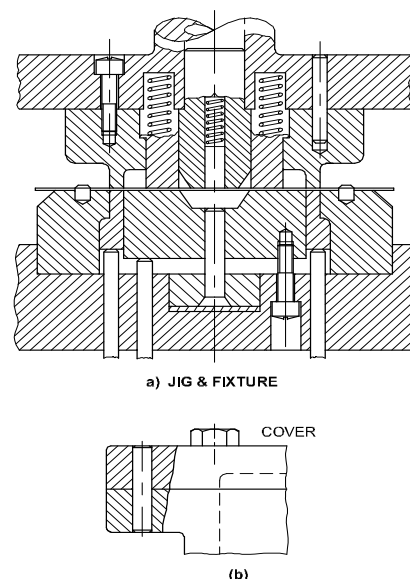

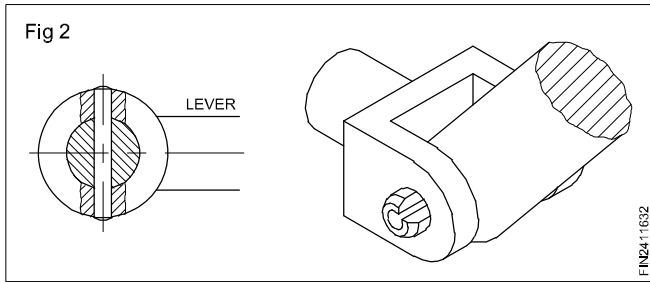

Cylindrical pins are available with different types of:

- Ends
- Tolerances
- Surface quality

Cylindrical pins are also available in un-hardened and hardened conditions.

Un-hardened cylindrical pins are of three types. (Fig 3)

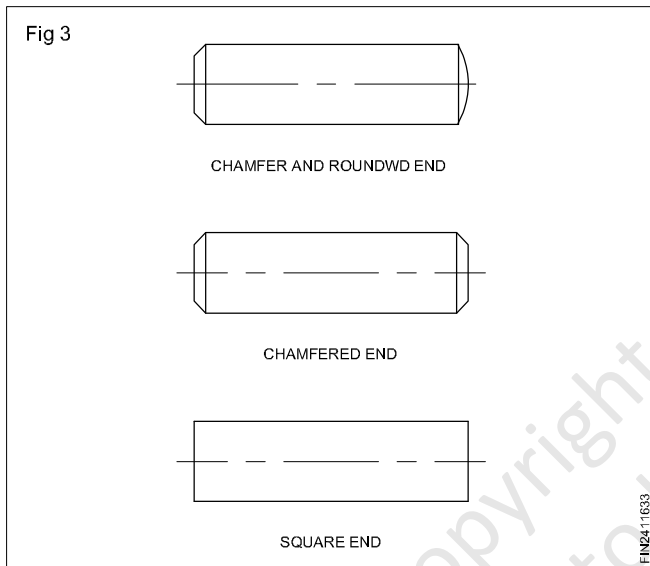

- Chamfered and rounded end
- Chamfered end
- Square end

They are useful in general assembly work.

Hardened cylindrical pins are made of high grade steel and are finished by grinding. (Fig 4) These pins can withstand higher shearing force. These pins are used in precision assemblies like jigs and fixtures and other tool making works.

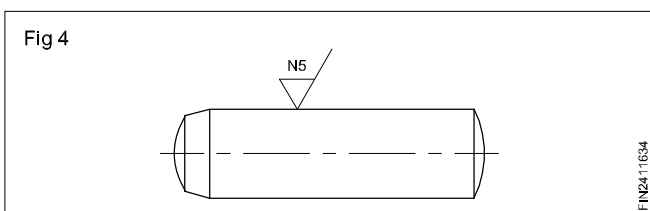

In tool assemblies the parts will be fixed by screws or bolts, (Fig 5) and are located by using cylindrical pins.

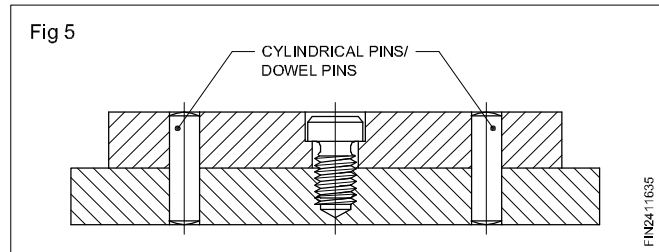

Hardened cylindrical pins are available with dimensional tolerance m6.

Un-hardened and hardened cylindrical pins are made to fit in the holes finished by standard reamers.

Cylindrical pins are designated by the name, nominal diameter, tolerance on diameter, nominal length and the number of B.I.S. Standard.

Example

A cylindrical pin of nominal diameter 10 mm, tolerance h8 and nominal length 20 mm shall be designated as-

Cylindrical pin 10h8x20 IS:2393.

Note: The I.S. number refers to un-hardened cylindrical pins. Cylindrical pins are also referred to as dowel pins.

Taper pins

Taper pins of different types are used in assembly work.

Taper pins allow for frequent dismantling and assembling of components without disturbing the precise nature of location. They are used to transmit small torques. (Fig 6)

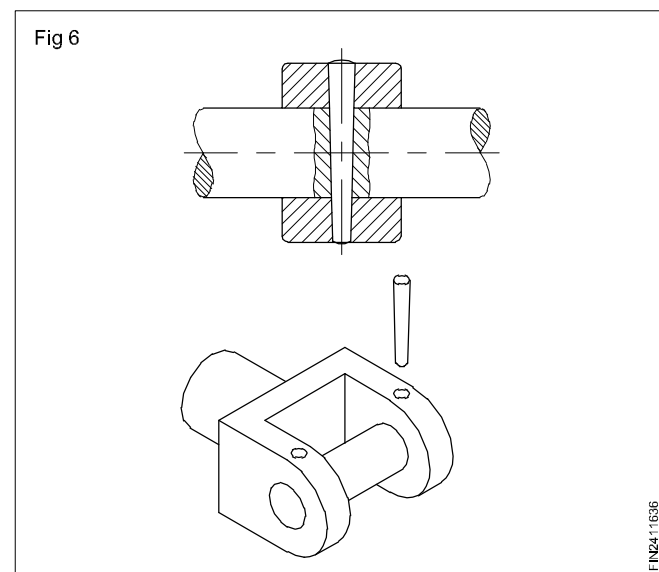

Taper pins are of three types. (Fig 7)

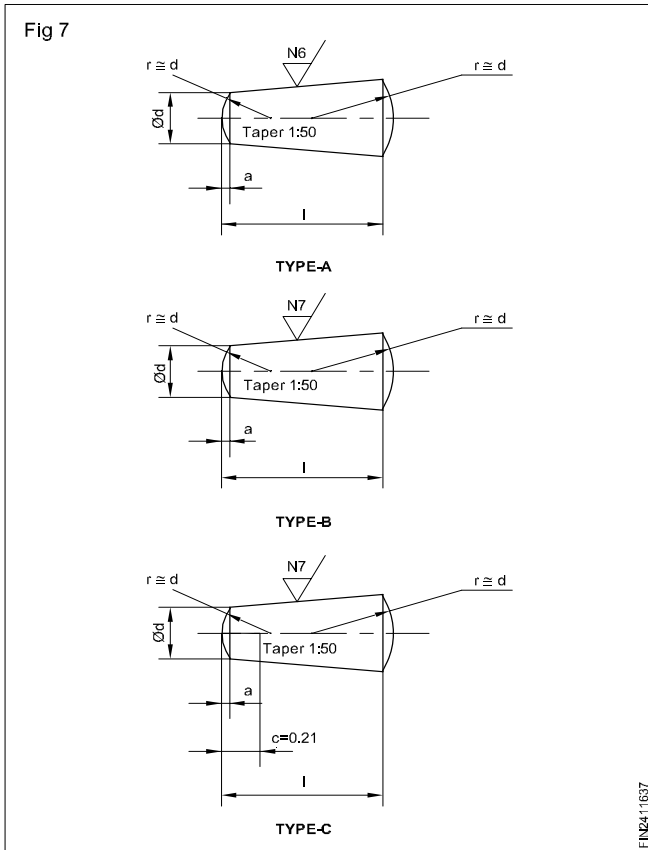

- Type A - Taper pins with a surface finish of N6.
- Type B - Taper pins with a surface finish of N7.
- Type C - Split taper pins with a surface finish of N7.

All taper pins have a taper of 1:50 and are finished within a dimensional tolerance of h10.

Taper pin types A & B assembly is shown in Fig 8 and type C is shown in Fig 9.

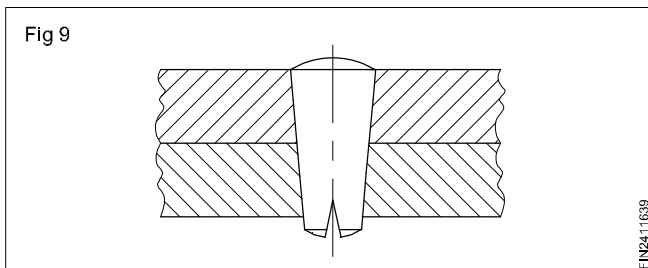
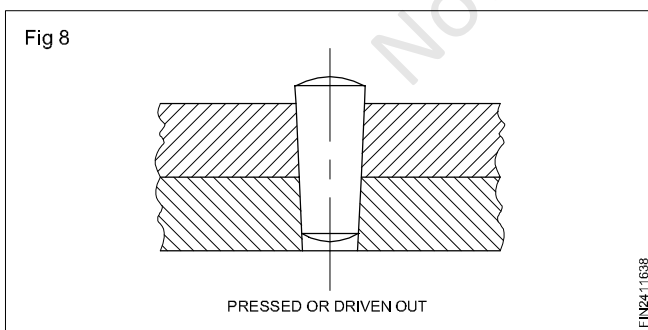

Split taper pin

In the case of split taper pins the split end can be slightly opened to ensure a more positive locking.

Taper pins are designated by name, type (A, B or C) nominal diameter, nominal length and number of the standard.

Examples

- i A taper pin of Type A of nominal diameter 10 mm and nominal length 50 mm shall be designated as - Taper pin A10 x 50 IS:6688.
- ii A split taper pin of nominal diameter 10 mm and nominal length of 60 mm shall be designated as - Split taper pin C10 x 60 IS: 6688.

The nominal diameter in the case of taper pins is the diameter at the small end of the taper.

Threaded taper pins are available for:

- Locking the pins and preventing loosening due to vibration (Fig 10)

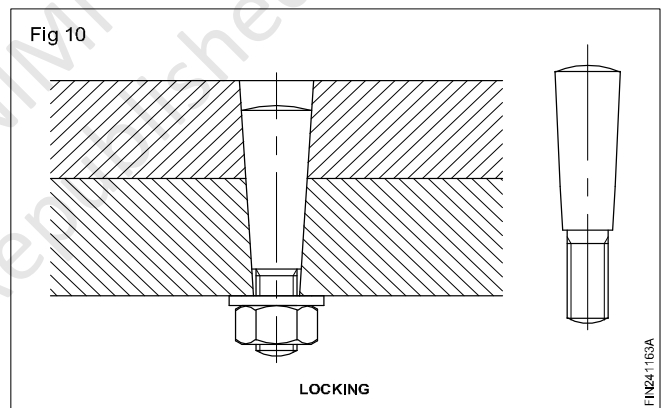

- Assisting in drawing the pins out of the blind holes. (Fig 11)

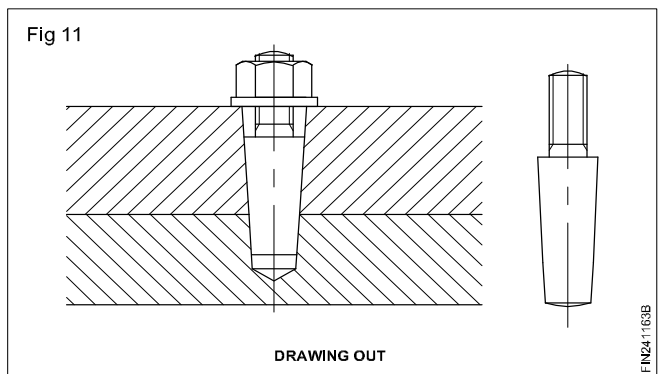

Threaded taper pins with internal threads are also available. (Fig 12)

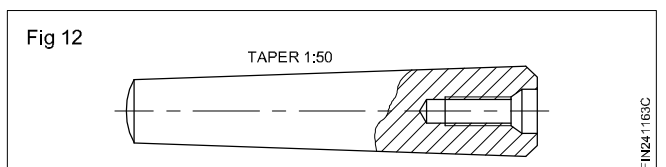

Grooved pins

These pins have three slots rolled on the outer surface. The sides of the grooves/slots bulge out. The holes in which slotted pins are used are not finished by reaming. Grooved pins are available as straight pins (Fig 13a), and tapered pins (Fig 13b). These are used in assemblies which are not dismantled frequently and where high accuracy is not required. (Fig 14)

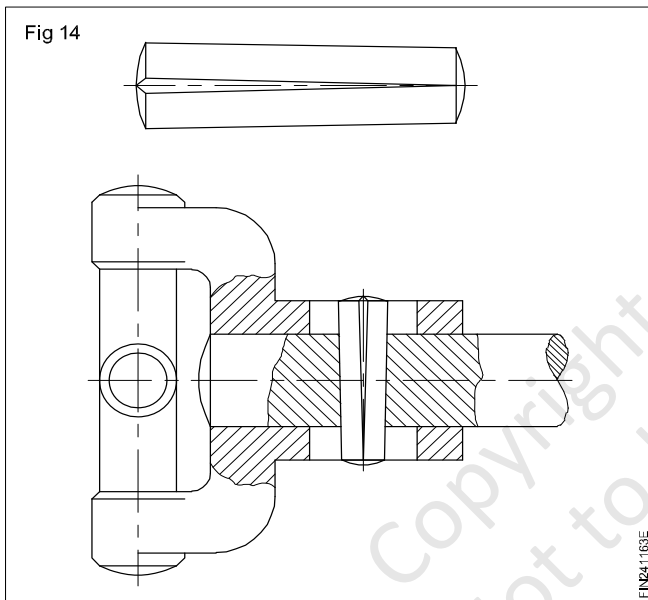
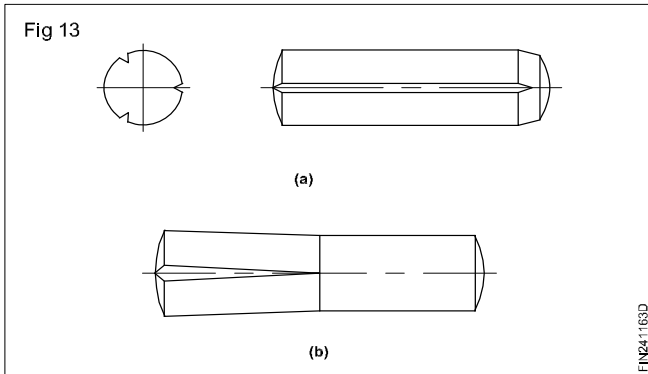

Grooved pins with head are also used in assembly involving small components. (Fig 15)

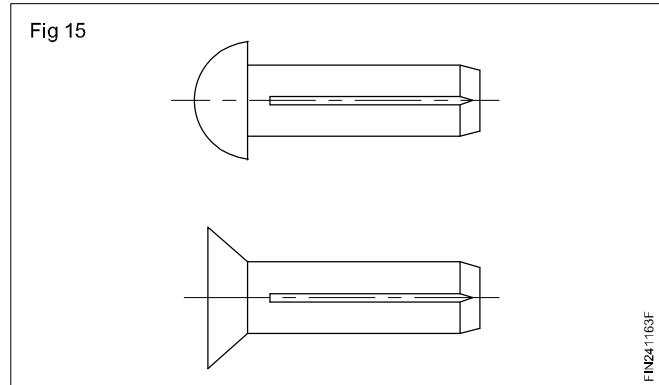

Spring pins (Fig 16)

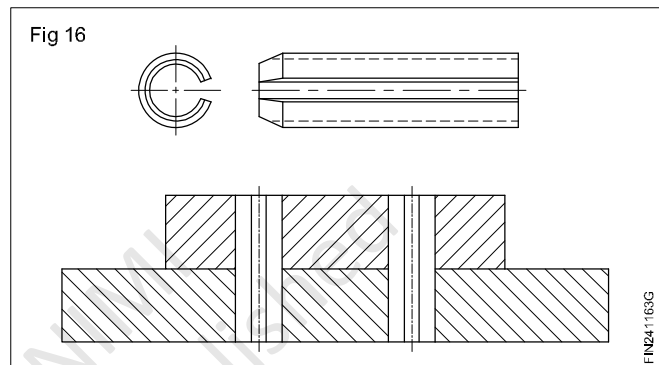

Spring pins are used for locating assemblies with wide tolerance in the corresponding holes. These pins are manufactured from flat steel bands and rolled to form a cylindrical shape. These springs will stay tight in the fitting hole because of the spring action.

Seal

Objectives: At the end of this lesson you shall be able to

- state the purpose of a seal
- name the material used for static seal
- state the types of static seals and their applications
- name the materials used for dynamic seals
- state the types of dynamic seals and their applications.

Purpose

A seal is used to prevent leakage.

It prevents dust, dirt and foreign particles from entering into the system.

Any machining process leaves behind a little imperfection of the surfaces of the mating components. A seal fills up the gap to prevent leakage from the system.

Types

- Static
- Dynamic

Static seal

It is used for sealing the contact areas between the surfaces where there is relative movement, eg. Gasket 'O' ring, bellows, etc.,

Materials used for gaskets

Static seal

- Compressed cork
- Oil-proof paper
- Graphite-impregnated cloth
- Asbestos with copper covering
- PTFE (Poly-tetrafluoroethylene)
- Copper
- Steel

Types of static seals

Compressed cork gasket (Fig 1)

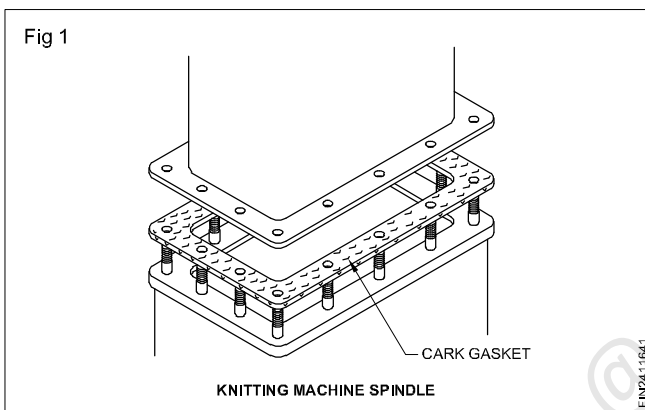

This is used for sealing between mating surfaces which are not having good surface finish. Compressed cork can be obtained in several thicknesses.

Paper (Fig 2)

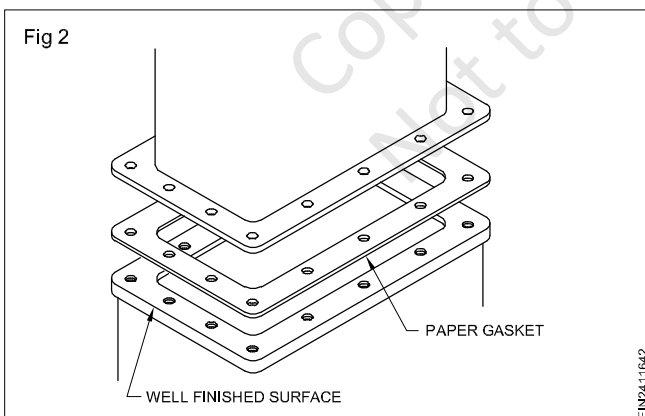

This is used between smooth and accurately finished joint surfaces. It can vary in thickness from thin paper to card and may be grease-proofed.

PTFE cord sealing (Fig 3)

This is suitable for use at very low temperature applications. The material is chemically inert and can be made into soft flexible strips and used to make either flat seals or gland packings.

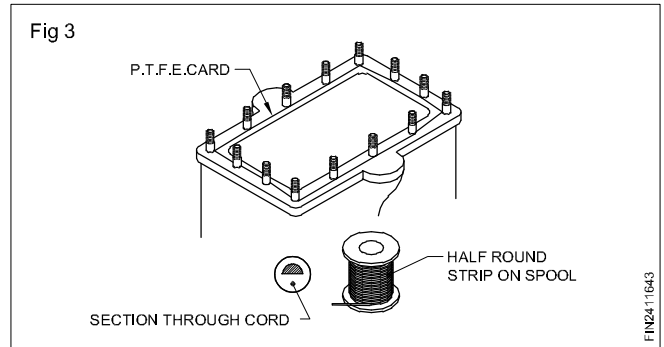

Rubber gaskets (Fig 4)

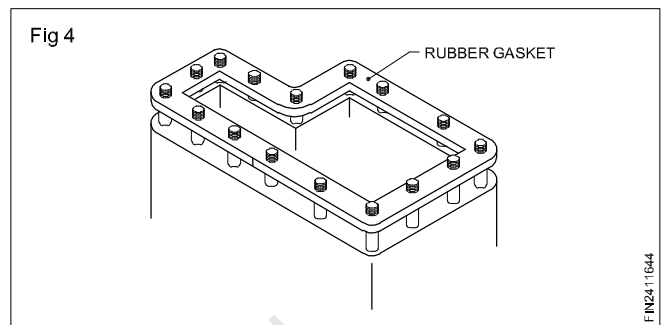

They are the good for sealing flanges of cold water connections. They are not suitable where oil comes in contact.

Graphite impregnated cloth (Fig 5)

This is a suitable material for hot water and steam joints.

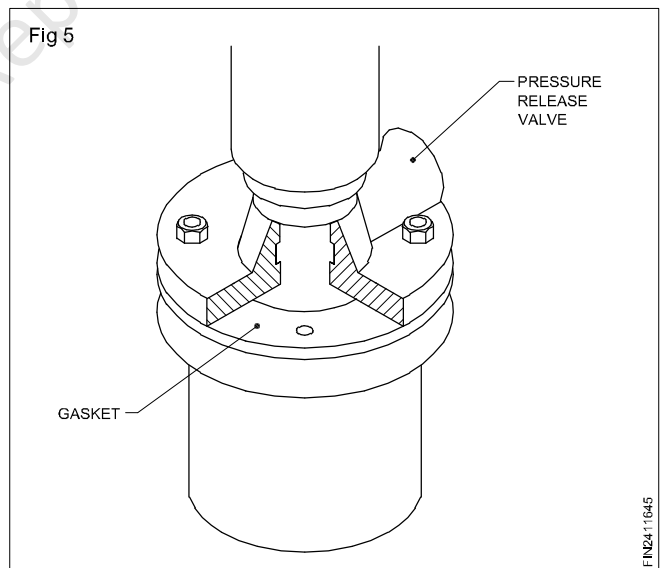

Metallic gaskets (Fig 6)

Hard metallic seals made of steel, copper or beryllium are used for high pressure joints found commonly in hydraulic system.

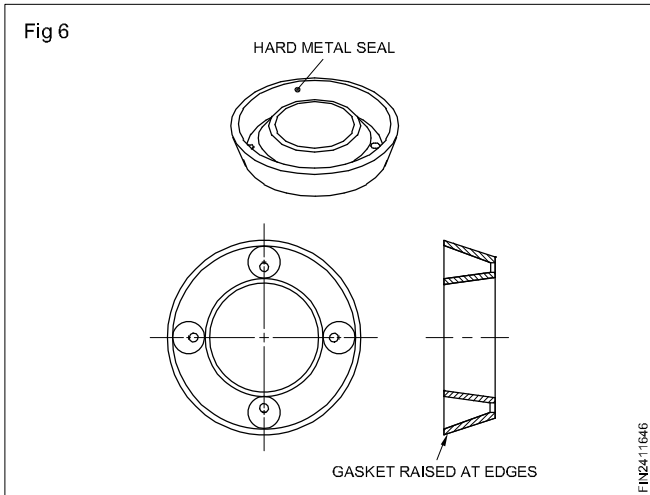

Asbestos covered with copper sheet gasket (Fig 7)

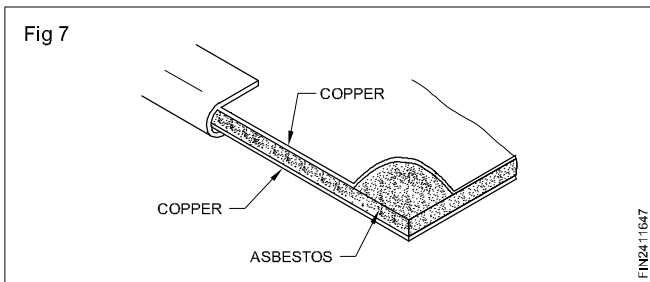

These are suitable for use in high temperature applications. Varnished paper gasket (Fig 8)

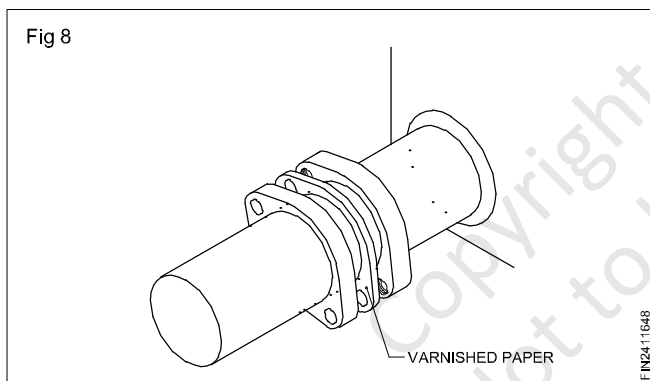

It is suitable for use where liquids would be absorbed into plain paper. The surface of the varnished paper gasket must not be cracked or damaged in any way.

Material used for manufacturing dynamic seal

- Natural rubber
- Nitrile
- Viton
- PTFE plastics
- Fluorosilicone
- Butyle
- Neoprene
- Fluorocarbon

Table 1 shows the allowable temperature range for different materials.

Table 1

Material	Temp.°C	Material	Temp.°C
Natural rubber	-50 to +80	Fluorosilicone	-50 to +100
Nitrile	-30 to +110	Butyle	-40 to +100
Viton	-40 to +180	Neoprene	-40 to +100
PTFE	-85 to +260	Fluorocarabon	-20 to +140

Types of dynamic seals

Dynamic seals are required to work under more exacting conditions than static seals because movement takes place between the surfaces being sealed.

O-ring seal (Figs 9 & 10)

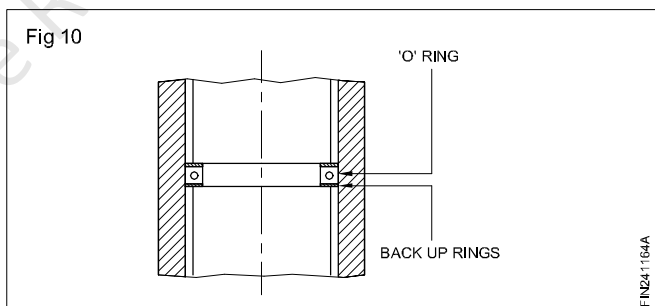
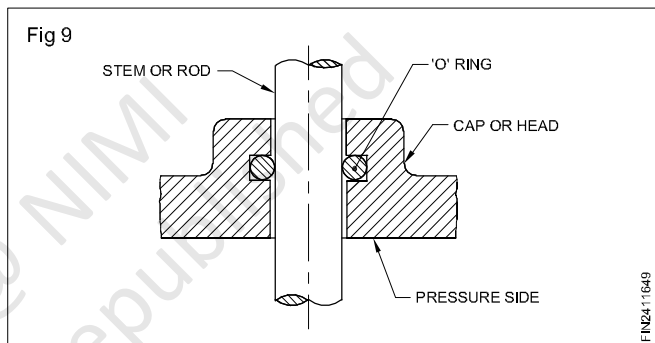

These are the most common types of dynamic seals in use and have many applications. When required to seal against high pressures, they are fitted with back-up rings. There are many similar seals made for special purposes that do not have a circular cross-section.

Radial lip seals

Radial lip seals are used primarily to retain lubricants in equipment with rotating, reciprocating or oscillating shafts. The secondary purpose is to exclude foreign matter.

Non-spring loaded seals

These are used to retain highly viscous materials like grease at shafts less than 600 m/min.

Spring-loaded seals (Fig 11)

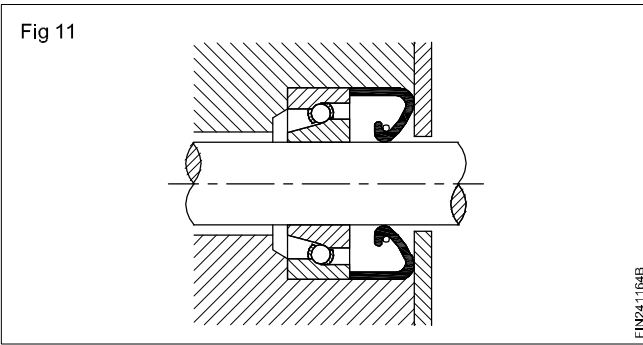

They are used to retain low viscosity lubricants such as oils at speeds up to 1000 m/min.

Wiper seal (Fig 12)

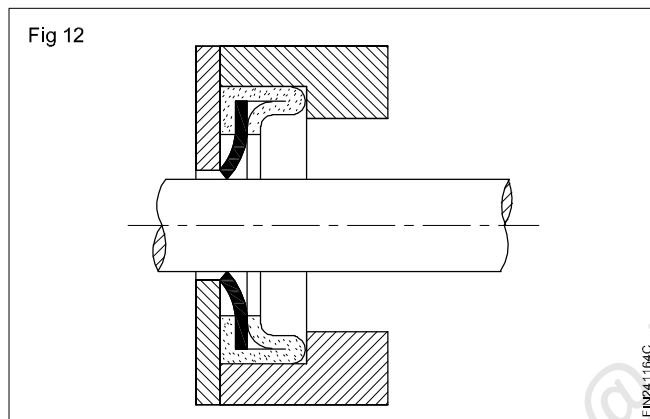

These seals are used in rotary and sliding operating conditions and are used to prevent dust or grit entering shaft bearings. The contacting surface of the seal wipers off the particles from the shaft.

'V' seals (Fig 13)

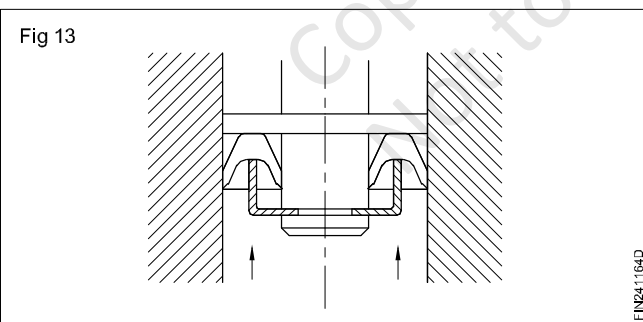

Fabric reinforced or leather seals are suitable for use against high pressure. These seals are available in various forms.

Flange seal (Fig 14)

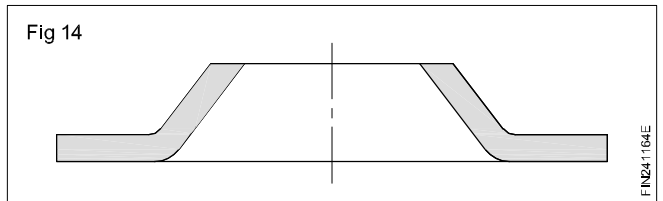

'V' type or Chevron seal (Fig 15)

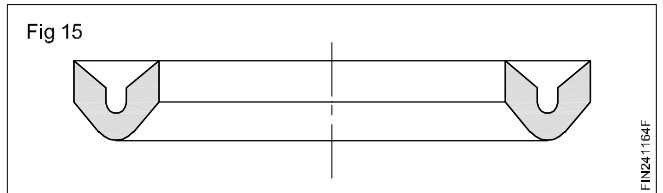

Cup seal (Fig 16)

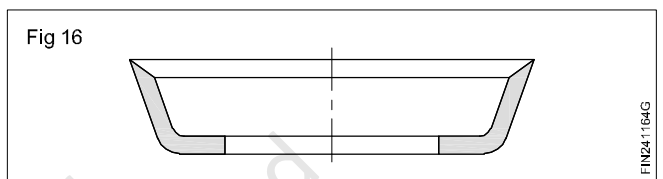

'U' type seal (Fig 17)

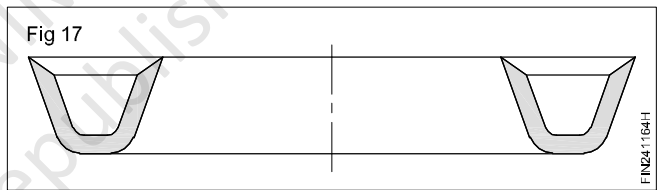

They are often used to form the seal between piston and cylinder assemblies in hydraulic equipment.

Labyrinth seals (Fig 18)

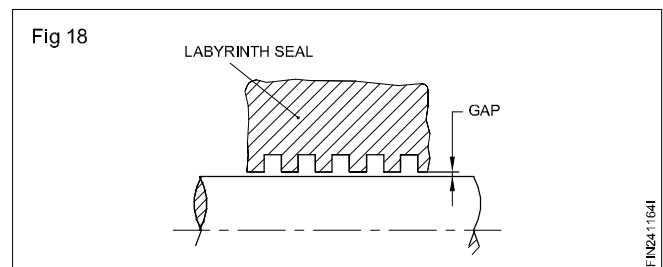

This is a clearance type of seal and it allows some amount of leakage. Labyrinth seals are used primarily to seal gases in compressors and steam turbines. This seal is commonly used in rotary operating conditions. The function of the seal is to provide radial clearance while preventing dust or dirt from entering into the system.

Torquing

Objectives: At the end of this lesson you shall be able to

- state torque in assembling
- state precautions to be observed during assembling & installation.

Torquing

While assembling, threaded fasteners are tightened as per thread manufacturer recommended torque value. If the torque is more than the recommendation, threads may damage on both fasteners and housing and tends to break.

Precautions observed during Assembling and installation

- Tighten the bolts to compress the gasket uniformly. Follow the sequence from side to side around the joint. (Fig 19).

- Use well lubricated fasteners and hardened flat washer.
- All bolts should be tightened in one-third increments, according to proper bolting patterns.
- Make final check pass at the target torque value moving consecutively from bolt to bolt
- Never use liquid or metallic based anti-stick or lubricating compounds on the gaskets. It creates Premature failure.

